

# FLUSH MOUNT, VANDAL RESISTANT BACK-LIT WEATHERPROOF ACCESS CONTROL KEYPAD



## **DOLKSF1KB** **Programming & Installation Manual**

**FOR ELECTRIC LOCK, INTER-LOCK AND SECURITY  
SYSTEM INSTALLATIONS**

# DOLKSF1KB

## Programming and installation manual

### INTRODUCTION

The DOLKSF1KB is a secure and waterproof keypad with two relay outputs. It can work independently as a stand-alone keypad or it can work as an additional controller to create a high-security dual keypad system. It also has a 34-bit Wiegand data output from the entry of a pin/code.

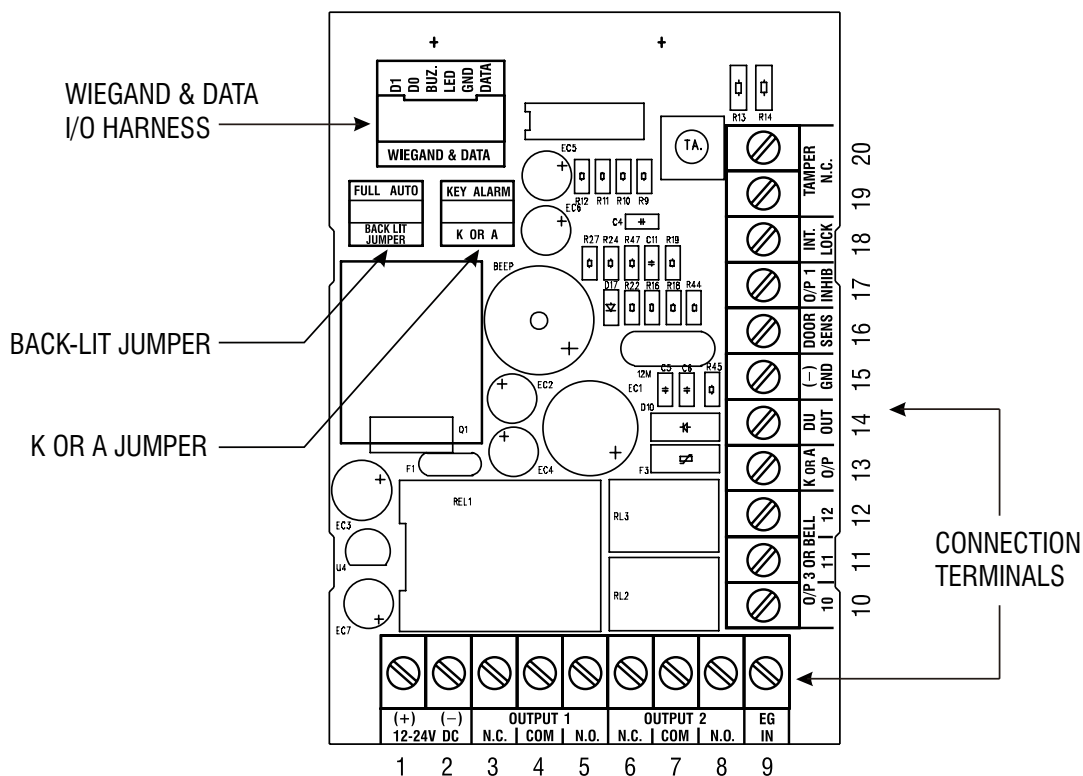

### CONNECTION TERMINALS

- 1-2: 12-24V DC (Power Input Terminal)
  - Connect 12V-24V AC/DC power. The (-) is the common ground.
- 3-5: OUTPUT (Output Relay 1)
  - N.C. (Normally closed)
    - Use N.C. for equipment that requires a constant flow of electricity to function properly. Ex. Magnetic locks, receivers, etc.
  - COM (Common ground)
  - N.O. (Normally open)
    - Use N.O. for equipment that requires a temporary surge of electricity to activate. Ex. Electric door locks, automated gates, etc.
- 6: EG IN ( Egress Input)
  - The optional EG. IN terminal is (-) and commonly connected to buttons. Buttons that are connected to EG. IN will grant access when pressed.
- 7: DU OUT (Duress Output)
  - When a Duress Code is entered, the DU OUT will switch to ground. Ex. It may be used to turn on a light, camera, or buzzer. It may also be used to trigger an alarm for a security system.
- 8-9: TAMPER N.C. (Tamper Switch Normally Closed Contact)
  - Normally closed while the keypad is secured on its box. It is open when keypad is

separated from its box. Connect this to an alarm system if necessary.

- 10-12: O/P 2 OR BELL (Output Relay 2)
  - 10 (Normally closed)
    - Use 10 for equipment that requires a constant flow of electricity to function properly. Ex. Magnetic locks, receivers, etc.
  - 11 (Common ground)
  - 12 (Normally open)
    - Use 12 for equipment that requires a temporary surge of electricity to activate. Ex. Electric door locks, automated gates, etc.
- 13: O/P 3 (Output Relay 3 N.O.)
  - Output 3 is a normally open terminal
- 14: DOOR SENS N.C. (Door Position Sensing Input -- Normally Closed)
  - DOOR SENS must be connecting to ground if not used. This feature can be connected to a normally closed device (ex. A magnet) to sense a door's status (being opened or closed). With DOOR SENS connected, the following features are possible:
    - Door Auto Re-lock
      - The system will immediately lock after a door/gate has been opened and closed.
    - Door Forced Open Warning
      - The system will signal a warning and trigger Alarm Output once the door is forced open without a valid access code or egress button. The warning signal lasts as long as programmed. Entering an output 1 code will deactivate the warning signal.
    - Open Door Warning
      - The door will signal a warning if the door is left open for longer than the programmed time.
    - Interlock Control
      - The Interlock Control is a two-keypad, two-door feature and it will disable the other keypad as long as its door is open and the keypads are connected by O/P 1 INHIBIT and INT LOCK.
    - Open Door Alarm
      - Open Door Alarm is designed for the emergency door. When the door is opened without a valid access code or egress button, the alarm will trigger. The warning signal lasts as long as programmed.
- 15: (-) GND (Common Ground)
- 16: O/P 1 INHIBIT (Output 1 Inhibit Control Input – Normally Open)
  - This is used for the dual keypad feature. It is normally open but will disable the keypad when closed. This is used in conjunction with INT LOCK.
    - NOTE: The inhibit function does not govern the Duress Codes and the Authorization Codes. These are always valid.
- 17: INT LOCK (Inter-lock Control Output)
  - This is used for the dual keypad feature. Connect this to the other keypad's O/P 1 INHIBIT.
- 18: K OR A O/P (Keypad Active or Alarm Output)
  - When any key is pressed, the K OR A O/P will switch to ground for 10 seconds. Ex. It may be used to turn on a light, camera, or buzzer for 10 seconds the moment a button is pressed. It may also be used to trigger an alarm for a security system. Be sure to switch the jumper to K or A located on the upper-left corner of the circuit board.
- LED Indicators
  - Red
    - This becomes a solid color when Access Lock is activated. It is also the Wiegand

LED in reader mode

- Yellow
  - It flashes on Standby. The Yellow LED also indicates the system's status in synchronization with the tones.
- Red/Green
  - It lights up Green for Output 1 activation; and Red for Output 2 activation.

### KEYPAD TONES AND THE LED SIGNALS

STATUS	TONES	LED SIGNALS
1. In programming mode		Solid Yellow
2. Successful key entry	1 Beep	1 Flash
3. Successful code entry	2 Beeps	2 Flashes
4. Unsuccessful code entry	5 Beeps	5 Flashes
5. Power-up delay	Continuous Beeps	Continuous Flashes
6. Output relay activation	1-second Beep	
7. Standby		1 flash every second
8. System refreshing		Quick flashes for 2.5 minutes
9. Pin already stored in system	Long Beep	

### THE JUMPER FOR BACKLIT OPTIONS

Located on the upper-left corner; the two options are for full lights or auto lights.

1. Full backlit – The keypad constantly illuminates.
2. Auto backlit – The keypad only illuminates during use.

### DIRECT ACCESS PROGRAMMING WITH CODE: 8080

By pressing the egress button and entering code: 8080 during the 1-minute booting time, the keypad will bypass the Master Code to enter Programming Mode. Take these following steps to use DAP:

1. Switch the power to off for about 1 minute to ensure total discharge
2. Switch the power to on. The system will have a 1-minute boot-up period
3. Press the egress button once to enable the DAP function
4. Enter: 8080, \*, \*. The Master Code will be erased and the keypad will enter Programming Mode.

### RESET TO FACTORY SETTINGS WITH CODE: 9999

While in programming mode, enter: 9999, # to reset the keypad to default factory settings.

- Allow up to 2.5 minutes for the keypad to reset. The yellow LED will indicate when the keypad has finished resetting
- The current Master Code will not reset

### ACCESS LOCK

Access Lock is an optional feature of the DOLKSF1KB. An authorization code can be set-up to control access. The authorization code will lock all access to all users until unlocked. While Access Lock is activated, the red LED will remain on.

### WIEGAND

This Wiegand section is not necessary if your DOLKSF1KB is standalone.

- The wires for Wiegand
  - Yellow – D1, Wiegand DATA 1

- Blue – D0, Wiegand DATA 0
- Brown – BUZ, Buzzer control line, 0V active
- Red – LED, Red LED control line, 0V active
- Black – GND, Common ground
- White – DATA, Data In/Out line, for decoder connection

## PROGRAMMING CHART

<b>DOLKSF1KB</b>		
<b>Keypad Feature</b>	<b>Code Entry</b>	<b>Comments</b>
Begin Programming Mode (Solid Yellow)	Master Code * *	Set System into Programming Mode. The default Master Code is 0000. Note: All of the following commands must be keyed while in Programming Mode.
End Programming Mode	* *	Return to normal operation.
Set Master Code	01 Master Code (4-8 digits) #	Set your new Master Code.
<b>Access Codes</b>		
Record Access Codes (Output 1, 2, 3)	Output Number: 1, 2, or 3 02 User number: 000-999 Access Code (4-8 digits) #	Set 4-8 digit code for general access. Each unique 4-8 digit code will require a new user number. Important Note: It is important to document your user numbers because users can be deleted and reassigned new codes for access.
Delete Access Codes (Output 1, 2, 3)	Output Number: 1, 2, or 3 05 User number: 000-999 #	Delete the user and remove their Access Code.
Clear all Access Codes	Output Number: 1, 2, or 3 00999 #	Clear all Access Codes depending on which output relay accessed.
<b>Authorization Codes</b>		
Set Authorization Code	02 Authorization Code (4-8 digits) #	The Authorization Code is for the owner to access the three outputs of the keypad and to enable/disable Access Lock.
Access output 1, 2, or 3	Authorization Code # Output: 1, 2, or 3	Each output can be accessed with one code.
Access Lock	Authorization Code # 9	Entering the Authorization Code during normal operation will toggle Access Lock on. Entering the Authorization Code again will toggle Access Lock off.
<b>Visitor Codes (Output 1 only)</b>		
Set a Visitor Code for one-time use	40 Visitor number: 01-50 00 Visitor Code (4-8 digits) #	The Visitor Code can only be used once until cleared.
Set a Visitor Code time limit	40 Visitor number: 01-50 Hours: 01-99 Visitor Code (4-8 digits) #	The Visitor Code will be cleared after the set time limit.
Delete Visitor Code	40 Visitor number: 01-50 #	Delete the visitor's code.
Clear all Visitor Codes	400999 #	Clear all Access Codes.
<b>Duress Codes</b>		

Set Duress code	4 Output number: 1, 2, or 3 User number: 01-50 Duress Code (4-8 digits) #	Duress Codes, when entered, trigger a distress signal and if the keypad is connected to a security alarm, then the keypad will silently trigger this alarm. Entering an Access Code or an Authorization Code will disable the Duress Output.
Delete Visitor Code	4 Output number: 1, 2, or 3 User number: 01-50 #	Delete the user's Duress Code
Clear all Visitor Codes	4 Output number: 1, 2, or 3 0999 #	Clear all Access Codes.
<b>Lock Settings</b>		
Set door unlock timer	5 Output number: 1, 2, or 3 Seconds: 1-99999 #	Set the amount of seconds the device will grant access before locking again.
Set Access Code to toggle [open/close]	5 Output number: 1, 2, or 3 0 #	Entering Access Code will toggle the lock to stay open. Entering the Access Code again will toggle back to lock.
<b>Safety Settings</b>		
Default safety setting	601 #	After 10 successive false codes, the keypad is disabled for 60 seconds
Duress safety setting	602 #	After 10 successive false codes, Duress is activated. Entering an Access Code or an Authorization Code will disable the Duress Output.
Extended safety settings	60 Number of false entries: 5-10 #	After 5-10 successive false codes, the keypad is disabled for 15 minutes or until the Authorization Code is entered.
Disable all safety settings	6000 #	
<b>Sound Settings</b>		
All sounds - On	711 #	All sounds will be enabled
All sounds - Off	710 #	All sounds will be disabled
Access sound - 1 second buzz	721 #	Upon unlocking, the keypad will signal granted access with a 1-second buzz
Access sound - 2 short beeps	720 #	Upon unlocking, the keypad will signal granted access with 2 short beeps
<b>Auto/Manual Code Entry Settings</b>		
Auto Code Entry Mode	701 #	The # key after entering an access code will NOT be required. Important Note: For this feature to work, ALL codes must be the same number of digits as the master code. Ex. If the Master Code is 6-digits, all other codes must be the 6 digits to enable Auto Code Entry Mode.
Manual Code Entry Mode	702 #	The # key after entering an access code will be required but all codes may vary in digit length.
<b>Blinking Yellow LED Settings</b>		
Blinking Yellow LED - On	731 #	The amber LED will blink every 2 seconds during functionality

Blinking Yellow LED - Off	730 #	The amber LED will not blink during functionality
<b>Door Timer Settings</b>		
Open Door Warning Timing	81 Seconds: 1-999 #	The door will signal a warning if the door is left open for longer than the programmed time.
Disable Open Door Warning	810 #	
Door Forced Open Timing	80 Seconds: 1-999 #	The system will signal a warning and trigger Alarm Output once the door is forced open without a valid access code or egress button. The warning signal lasts as long as programmed. Entering an output 1 code will deactivate the warning signal.
Disable Door Forced Open	800 #	
Open Door Alarm Timing	91 Seconds: 1-999 #	Open Door Alarm is designed for the emergency door. When the door is opened without a valid access code or egress button, the alarm will trigger. Important Note: Either "Door Forced Open" or "Open Door Alarm" can be activated. Both features should not be activated together
Disable Open Door Alarm Timing	910 #	
<b>Egress Settings</b>		
Single press, no warning	901 Activation Delay seconds: 0-99 #	Pressing the egress button will silently grant access
Single press, warning	902 Activation Delay seconds: 0-99 #	Pressing the egress button will sound a warning and grant access
Single press, warning, and alarm	903 Activation Delay seconds: 0-99 #	Pressing the egress button will sound a warning, activate alarm, and grant access
Hold press, no warning	904 Hold duration in seconds: 0-99 #	Holding the egress button for the defined duration will silently grant access
Hold press, warning	905 Hold duration in seconds: 0-99 #	Holding the egress button for the defined duration will sound a warning and grant access
Hold press, warning, and alarm	906 Hold duration in seconds: 0-99 #	Holding the egress button for the defined duration will sound a warning, activate alarm, and grant access
<b>Wiegand</b>		
Stand-alone Mode (Default)	940 #	Keep this mode if not using Wiegand
Code Reader Mode	941 #	The keypad provides Wiegand Data Output for all entries but does not operate the outputs. It solely becomes a code reader
Master Keypad of Dual Keypad Mode	942 #	The Master Keypad will transfer all the programmed feature data to the access controller. Note: Setting multiple keypads to master will confuse the system.

Slave Keypad  
of Dual Keypad  
Mode

943 #

The Slave Keypad requires data from the  
Master Keypad to operate.  
Note: Each keypad in Dual Keypad Mode  
can have its own individual set of codes.

## BASIC WIRING EXAMPLE – Basic wiring of a stand-alone door lock

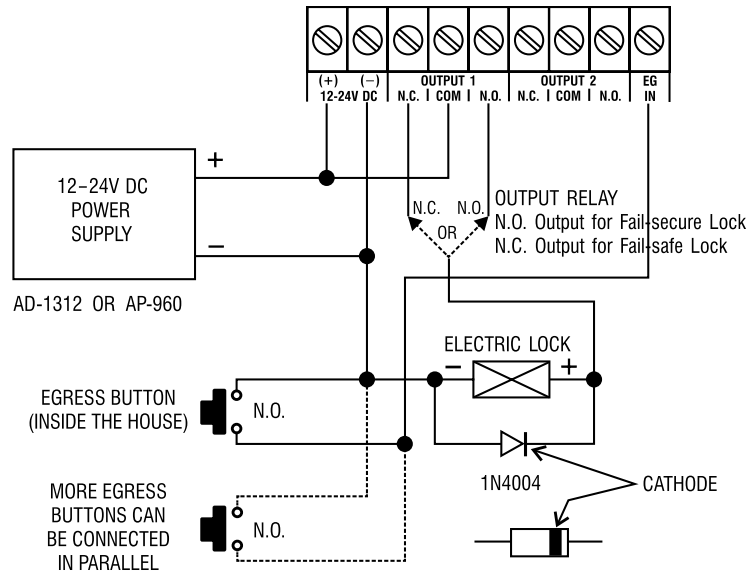

Note:

- Connect 1N4004 as close as possible to the lock parallel with the lock power terminals to absorb the back EMF and prevent keypad damage. The 1N4004 is not required for AC power.
- To avoid electrostatic discharge from interfering with the keypad, always ground the terminal.
- Always connect DOOR SENS to ground.

## SPECIFICATIONS

### Operating Voltage:

12V-24V DC, Auto adjusting

### Operating Current:

40mA (quiescent) to 100mA (three relays active)

### Operation Temperature:

-4 F to +158 F

### Environmental Humidity:

5-95% relative humidity non-condensing

### Working Environment & Ingress Protection:

All weather, IP-66

### Number of Users:

Output 1 – 1,000 User PINs + 50 Duress Codes

Output 2 – 100 User PINs + 10 Duress Codes

Output 3 – 100 User PINs + 10 Duress Codes

### Number of Visitor Codes:

50, programmable for one time or with the time limit

### Timings for Code Entry:

10 seconds waiting for next digit entry

### The Timers:



Three 1-99,999 Seconds (Over 24 Hours possible) Independent Programmable Timers for O/P 1, 2 & 3

**Egress Button:**

Programmable for Instant, Delay with Warning and/or Alarm  
Momentary or Holding Contact for the Exit Delay

**Input Sensing Terminals:**

**a)** Door position, **b)** Egress, **c)** O/P 1 inhibit

**Output Control Terminals:**

Transistor Open Collector 24VDC/100mA sink Max for the following outputs

**a)** Duress, **b)** Alarm, **c)** Key Active, **d)** Output 3 (Door Bell version only), **e)** Inter-lock

**Output Contact Ratings:**

Output Relay 1 – N.C. & N.O. dry contacts, 5A/24VDC Max.

Output Relay 2 – N.C. & N.O. dry contacts, 1A/24VDC Max.

Output Relay 3 – N.C. & N.O. dry contacts, 1A/24VDC Max. (N.O. contact only for Door Bell version)

Tamper Switch – N.C. dry contact, 50mA/24VDC Max.

**Dimensions:**

DOLKSF1KB – 4 3/4(H) X 3 1/8(W) X 2(D) inches

**Weight:**

DOLKSF1KB – 1 lb net

**Housing:**

Cast aluminum, power paint coating outer box & plastic inner box

**Faceplate Material:**

1/16 inch stainless steel

Specifications are subject to change for modification without notice

**DOLKSF1KB QUICK START GUIDE**

As the DOLKSF1KB is powered, it will begin its booting process and beep for 1 minute. When the DOLKSF1KB is finished:

**Enter Programming Mode and Add Users:**

1. Enter:    (Note: Default [Master Code]: 0000)
2. Enter:
3. Enter:
4. Enter:

**For User Access:**

To gain access: Enter the

**TRANSMITTER SOLUTIONS WARRANTY**

The warranty period of this product is 12 months from the purchasing date. During this period, if the product does not operate correctly due to a defective component, the product will be repaired or replaced at the sole discretion of Transmitter Solutions. This warranty does not extend to the product's casing, which can be damaged by conditions outside of the control of Transmitter Solutions.



7380 S. Eastern Ave, Suite 124-320 • Las Vegas, NV 89123  
(866) 975-0101 • (866) 975-0404 fax  
[www.transmittersolutions.com](http://www.transmittersolutions.com)