

PTI *Falcon* Access Control System

Installation and Operation Manual **For 15 and 20 Function type Falcons**

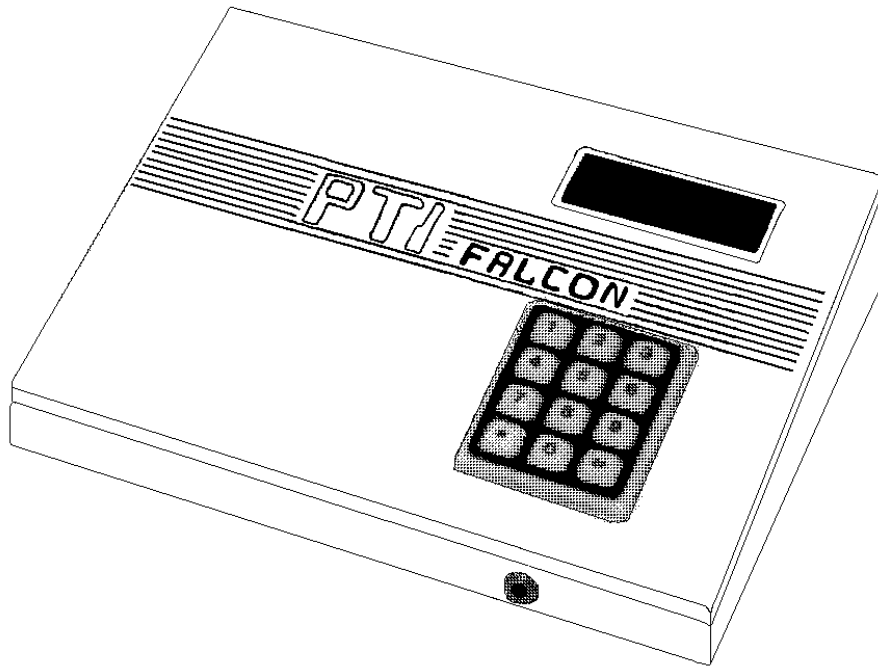

Includes: single wire and type 1 door alarms

**PREFERRED TECHNOLOGY INC.
8271 East Gelding Drive
Scottsdale, AZ. 85260
480-991-1259**

WARNING: This equipment generates, uses, and can radiate radio frequency energy and if not installed and used in accordance with the instructions manual, may cause interference to radio communications. It has been tested and found to comply with the limits for a Class A computing device pursuant to Subpart J of Part 15 of FCC rules, which are designed to provide reasonable protection against such interference when operated in a commercial environment. Operation of this equipment in a residential area is likely to cause interference in which case the user at his own expense will be required to take whatever measures may be required to correct the interference.

Contents

Introduction	1
Equipment Overview	3
The Base Unit	3
The Remote Keypad	4
Connecting Cables	5
Accessories	6
Individual Door Alarms - Expandable	7
Individual Door Alarms - Single Wire	8
Installation	9
Remote Keypad Installation	9
Keypad Switches	11
Testing the Keypad	13
Individual Door Alarm Installation - Expandable	13
Mux Box Switches	15
Individual Door Alarm Installation - Single Wire	17
Mux Box Switches	18
Testing the Alarm Wiring	19
Testing Mux Box Communications	21
Base Unit Installation	21
Programming	25
General Information	25
Programming a New Installation	26
Function #1 - Set Time/Date	27
Function #2 - Set Business Hours	28
Function #3 - Set Holidays	29
Function #4 - Set Building Sizes	30
Function #5 - Add New Unit	31
Function #6 - Suspend Unit	33
Function #7 - Release Unit	34
Function #8 - Remove Unit	35
Function #9 - Set 24hr Unit	36
Function #10 - Save on Tape	37
Function #11 - Load from Tape	38
Function #12 - Print Reports	39
Function #13 - Adjust Contrast	40
Function #14 - Open Entrance	41
Function #15 - Set Master Code	42
Function #16 - Door On/Off	43
Function #17 - Clear Alarms	44
Function #18 - Read Doors	45
Function #19 - Unknown Door Print	46
Function #20 - Set Relay Times	47

Specifications	49
Base Unit Specifications.....	49
Remote Keypad Specifications	49
Alarm Mux Specifications	49
 WARRANTY.....	 51

Introduction

The PTI Falcon SS is a multi-point access control system capable of hosting up to sixteen remote keypads or door alarm controllers. Multiple building groups are supported with multiple units per building. Each unit may be restricted to normal business hours access or given twenty four hour access. Separately specified business hours for weekdays, Saturdays, Sundays, and holidays are supported with up to thirty two preprogrammed holiday dates. Any individual unit code may be locked out with a few simple keystrokes. All access activity is logged on a standard computer style printer using standard paper. When used with the optional door alarm system, all door activity is also logged. The PTI Falcon also has built-in rechargeable batteries which allow the programming unit to remain completely operational during a power failure. The simple menu driven programming is easily mastered using the thirty two character alphanumeric display.

The PTI Falcon cassette tape backup system is unique in the industry, allowing you to retain a non-volatile copy of your customer data on a standard audio cassette tape with a standard cassette recorder. This simple concept allows you to separate your customer data from the machine and allows total elimination of accidentally erased memories.

The PTI remote keypad contains a backlit silicone rubber booted keypad which is highly weather resistant and a backlit wide temperature liquid crystal display capable of displaying thirty two characters of alphanumeric data. The keypad unit can be used in total darkness with no exterior lighting required. The unique display allows the customer to be given instructions on how to use the keypad as well as a reason for denial in the case of customer lockout.

Both the programming console and the exterior keypads feature rugged steel construction with a baked enamel finish. All exterior units contain stainless steel screws, resulting in an industrial rather than commercial grade product.

Equipment Overview

The Base Unit

The Base Unit serves as the main programming console for the PTI Falcon access control system. Figure One illustrates the front view of the PTI Falcon Base Unit.

At the top of the unit there is a two line by sixteen character liquid crystal display. When the display is not being used for programming, it will display the current date and time.

The center of the unit contains a keypad in a standard telephone arrangement. Often during programming, you will be asked a "Yes or No" question. When responding, the "*" key indicates "No" and the "#" key indicates "Yes". If you make a mistake when entering numeric data, the "*" key can also be used to backup or rubout one character at a time. When the correct data has been keyed in, the "#" key serves as the <Enter> key to save the data in memory.

The front of the Base Unit contains a 3.5mm standard audio cassette jack, which is used by the cassette tape memory backup system. This one plug is used for both recording and playing a tape with the Base Unit.

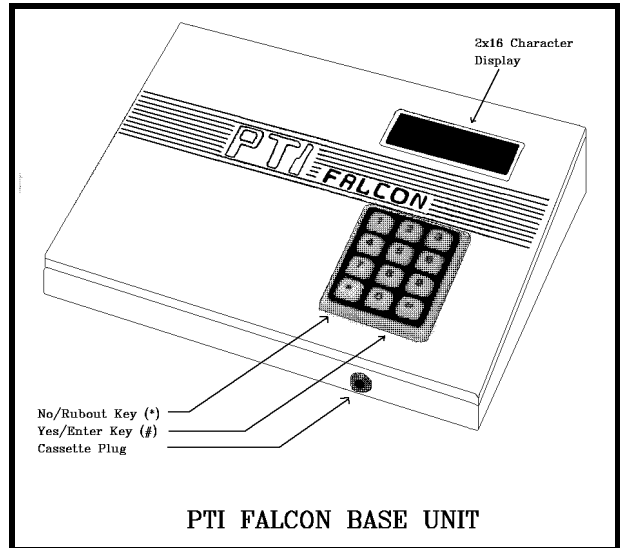

Figure One

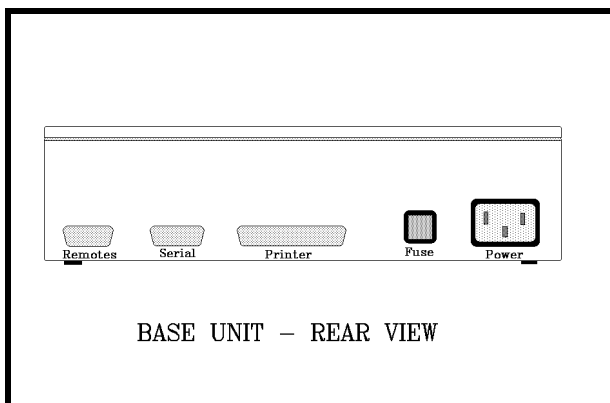

Figure Two

Figure Two illustrates the rear view of the PTI Falcon Base Unit.

The left most connector is a nine pin D-subminiature female connector and connects to the remote keypads and other remote devices. If door alarms are in use, the alarm relay contacts are also present on this connector. In addition, when this connector is plugged in, the internal battery backup is also connected.

The center connector is a nine pin D-

subminiature male connector and contains the RS232C serial port if the optional interface is purchased.

The long right hand connector is a twenty five pin female which connects the serial printer to the PTI Falcon.

Next to the connectors are the fuse holder and power line connector. The fuse may be released by inserting a small screwdriver into the notch in the top of the fuse holder and pressing down on the plastic release clip. **WARNING: TO PREVENT ELECTRIC SHOCK, NEVER REMOVE OR INSERT THE FUSE WITHOUT FIRST UNPLUGGING THE PTI FALCON BASE UNIT FROM THE POWER OUTLET!** The power line connector contains an integral RF line filter to reduce radio frequency interference with other electronic devices. **WARNING: ALWAYS UNPLUG THE POWER CORD FROM THE WALL OUTLET FIRST, BEFORE UNPLUGGING THE CORD FROM THE BACK OF THE PTI FALCON. ALWAYS PLUG THE POWER CORD INTO THE BACK OF THE PTI FALCON BEFORE PLUGGING THE OTHER END INTO A WALL OUTLET.**

The Remote Keypad

A PTI Falcon access control system may contain multiple remote keypads such as the one illustrated in Figure Three. The number of remote keypads will depend on the number of entry points to the facility through which you desire to control access.

The Remote Keypad unit contains a silicon rubber booted keypad in a typical telephone style arrangement. The keypad contains four small light emitting diodes (LED's) behind the rubber boot which serve to light the keypad for night use. These lights are continuously on, although they are not bright enough to be seen in daylight.

The Remote Keypad unit also contains a thirty two character liquid crystal display (LCD) arranged as two lines with sixteen characters per line. The display is fully alphanumeric which allows complete text to be displayed rather than just numbers.

The LCD also contains an electroluminescent (EL) light panel behind it for night time viewing. This light only comes on when the "*" key is first pressed on the keypad to begin a transaction.

Alphanumeric LCD's are available in either "top view" or "bottom view" models, which specifies the viewing angle for maximum contrast. The PTI Remote Keypad contains a "top view" LCD, so the best viewing angle will be when the user's line of sight is from above the display looking down on it.

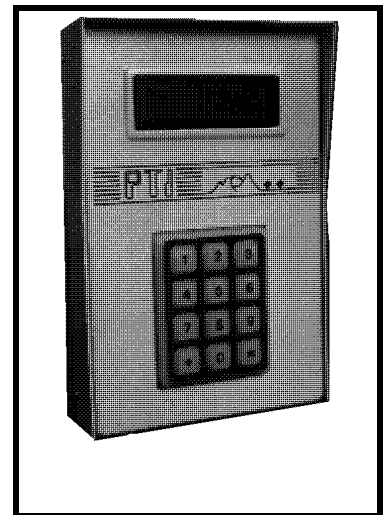

Figure Three

Connecting Cables

The PTI Falcon requires several connecting cables for proper operation. Figure Four illustrates the power cord for the PTI Falcon. When installation is complete and you are ready to turn on the system, the female end of the power cord will plug into the power outlet on the back of the PTI Falcon and the male end will plug into a 120 VAC 60Hz outlet. **WARNING: TO AVOID SHOCK HAZARD, NEVER PLUG THE MALE END OF THE POWER CORD INTO A WALL OUTLET WITH THE FEMALE END EXPOSED!**

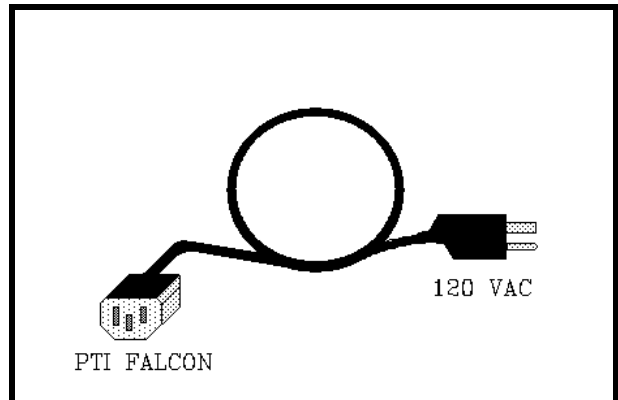

Figure Four

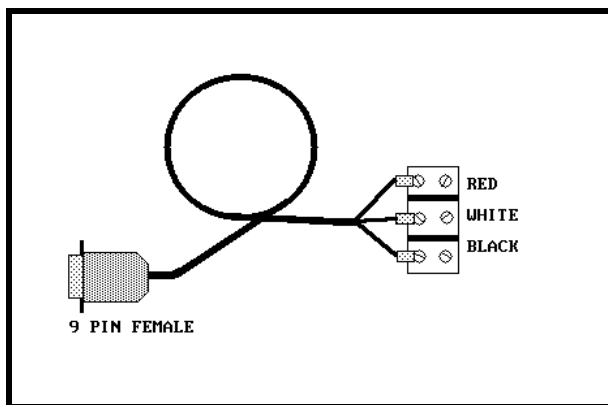

Figure Five

All of the remote keypads and other devices communicate with the PTI Falcon through the remote patch cord. This cord consists of a 9 pin male connector which plugs into the corner connector on the PTI Falcon. A three position terminal block is on the other end. It is on this terminal block that the field wiring from the remote devices will terminate. Systems with PTI door alarms will have a second three position terminal block on the end of this cable which provides the relay contacts to trigger the alarm siren.

If you have purchased a printer for the PTI Falcon, it will come with a printer cable similar to the one illustrated in Figure Six. The printer cable has a twenty five pin male connector on each end. One end plugs into the printer connector on the back of the base unit, and the other end plugs into the printer. This cable is reversible, so direction is not important.

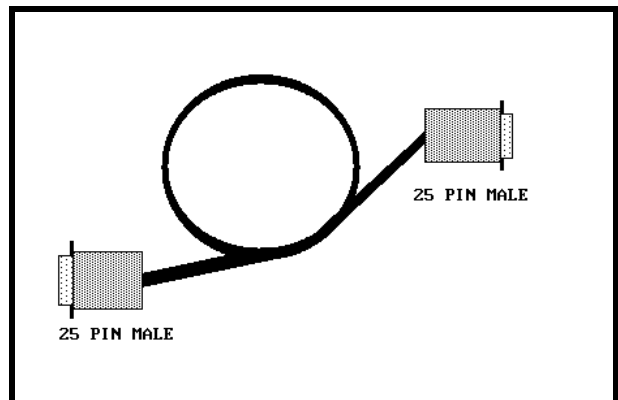

Figure Six

If you have purchased the optional computer interface for the PTI Falcon, you will have a computer interface cable similar to the one pictured in Figure Seven. The PTI Falcon end of the cable will have a nine pin female connector and will plug into the nine pin serial port connector on the back of the PTI Falcon base unit. The other end of the cable will have either a nine pin female connector or a twenty five pin female connector, depending on which was ordered. This end will plug into the serial port on your computer or modem. This cable is not reversible, so the PTI Falcon end of the cable will be labeled appropriately.

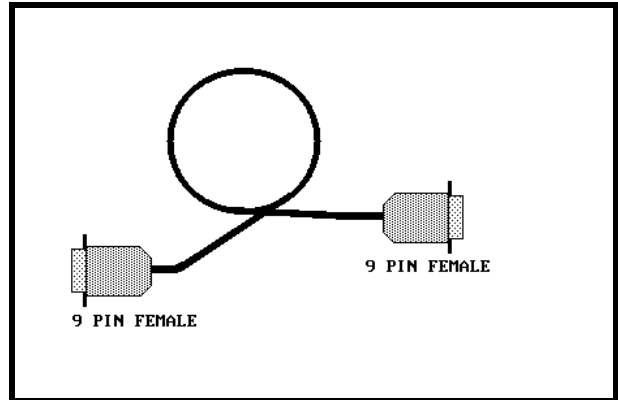

Figure Seven

Accessories

Figure Eight illustrates the PTI gooseneck stand. This stand is designed to mate with the PTI remote keypad when it is used in a drive up application. The keypad mounting plate contains a center wiring hole which allows the wire to be fed up through the stand from underground conduit and three mounting holes which match the keypad backplate mounting holes. The mounting holes are tapped for an 8-32 machine screw.

The bottom plate of the gooseneck stand contains a center conduit hole and four mounting holes arranged on four inch centers. There is a cover plate which slides down over the bottom plate after mounting to hide the mounting plate bolts.

It is highly recommended that the gooseneck stand be electrically grounded to minimize the impact of lightning and static atmospheric charge on the keypad.

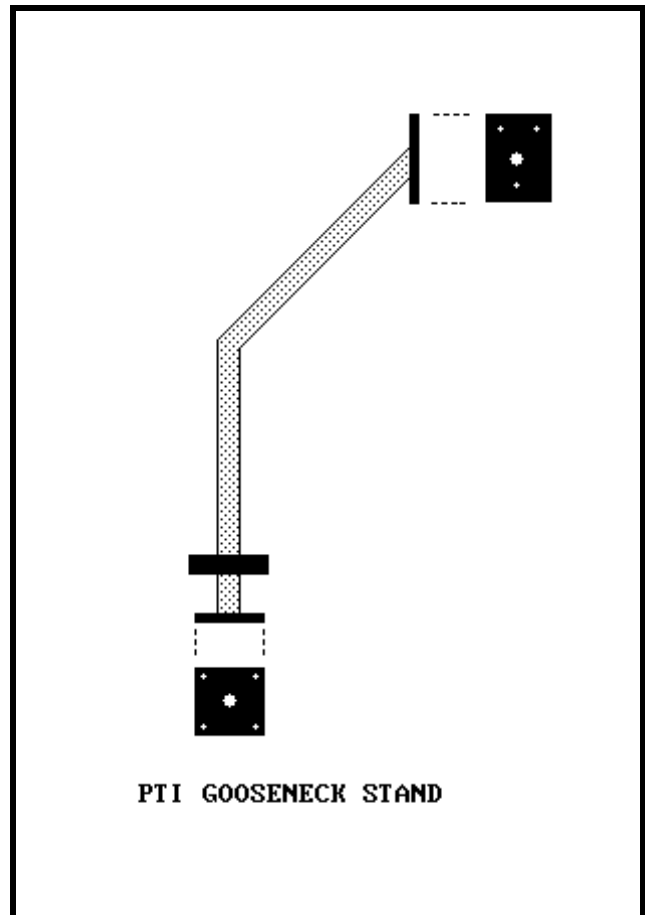

Figure Eight

Individual Door Alarms - Expandable

The PTI Falcon supports the use of PTI individual door alarms. PTI door alarms require the use of door alarm multiplexer (mux) boxes, such as the one pictured in Figure Nine. A mux box contains a master circuit board capable of multiplexing forty eight doors. If the box must multiplex more than forty eight doors, up to three expansion boards may be added to the master board. Each expansion board adds an additional forty eight doors to the box, bringing the maximum number of doors on one box to one hundred ninety two.

Each building on the property must have its own multiplexer box or boxes. Multiplexer boxes are connected to the PTI Falcon base unit through the same three wire RS485 interface as the remote keypads.

Each alarmed door must have a magnetic door switch mounted on the door. The mux box will connect to one wire from each switch in addition to a common wire which connects to all switches. Fifty conductor telephone cable is often used for the individual door wiring. If one cable is used for one mux board, it allows forty eight conductors for the forty eight door switches and two conductors for the common wire in order to increase the effective wire size for the common wire.

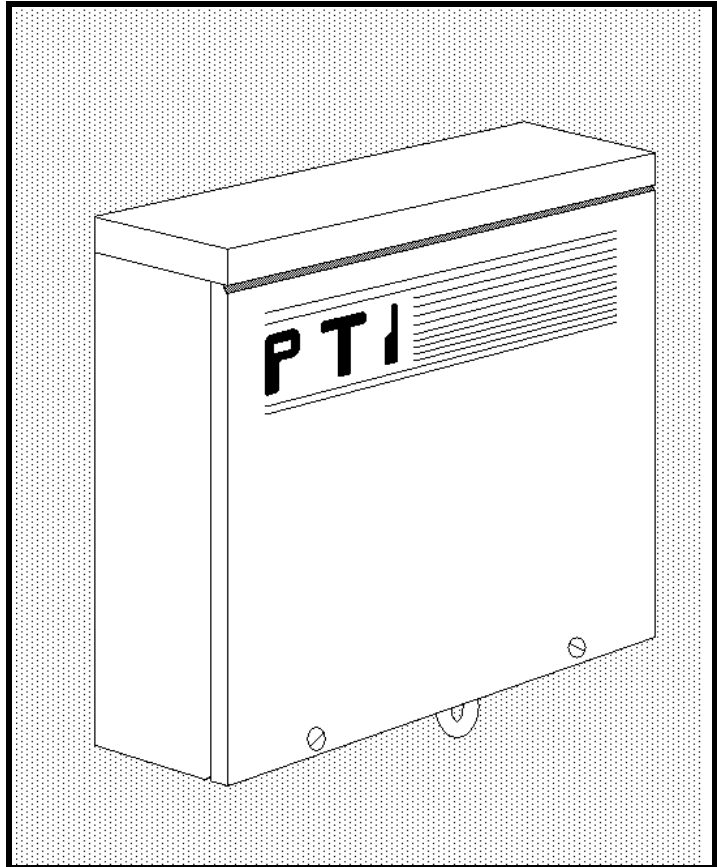

Figure Nine

In addition to the door wiring and communication wiring, each master mux board requires 12 VAC power in order for the board to operate. A single 12 VAC plug-in style transformer is often used to power all of the multiplexer boxes from a central point. This allows all of the field wiring to be low voltage.

Each mux box contains a rechargeable battery pack to sustain the operation of the alarm box during power outages and a tamper switch to detect break-ins to the mux box itself.

Individual Door Alarms - Single Wire

The PTI Falcon may also utilize PTI single wire door alarms rather than expandable door alarms. The PTI single wire system uses a **Door Control Unit (DCU)** box at the head end of a three conductor cable which runs from unit to unit. Each unit contains a small **Door**

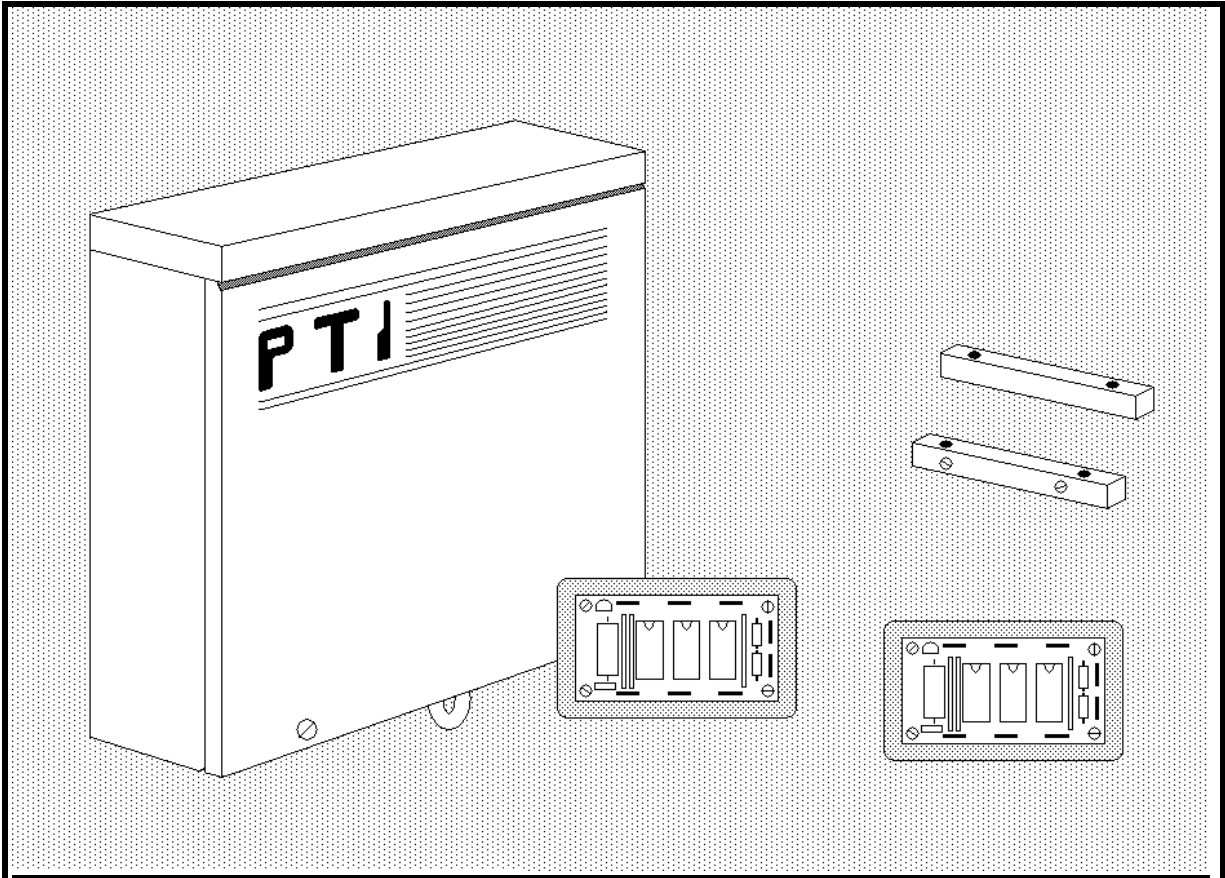

Figure Ten

Interface Unit (DIU) circuit board mounted in a standard single gang electrical box which connects to the three conductor cable. Figure Ten illustrates the appearance of the DCU box and DIU boards. Use of the DIU modules allows individual identification electronically of each door even though separate wires are not run from each door. Each DCU box can support up to one hundred DIU modules on a single run of three conductor wire using 22 gauge wire. The PTI Falcon base unit communicates with the DCU the same way as with an expandable door alarm mux box, and cannot tell the difference between the two.

Installation

Remote Keypad Installation

Open the Remote keypad by removing the four stainless steel button head machine screws on the sides of the keypad case. The front and back half will now separate. Mount the back plate to the desired keypad location using the three keyed holes.

Figure Eleven is a diagram of the circuit board found in the front half of the Remote keypad. The items of interest to the installer are as follows:

- (1) Depluggable terminal strip TS1 with six terminals at the bottom left of the circuit board.
- (2) Depluggable terminal strip TS2 with six terminals at the bottom right of the circuit board.
- (3) Power line fuse on the bottom left side of the board.
- (4) Relay contact fuse on the bottom right side of the board.
- (5) Red rotary switch near the bottom center of the board.
- (6) Eight position DIP switch under the red rotary switch.

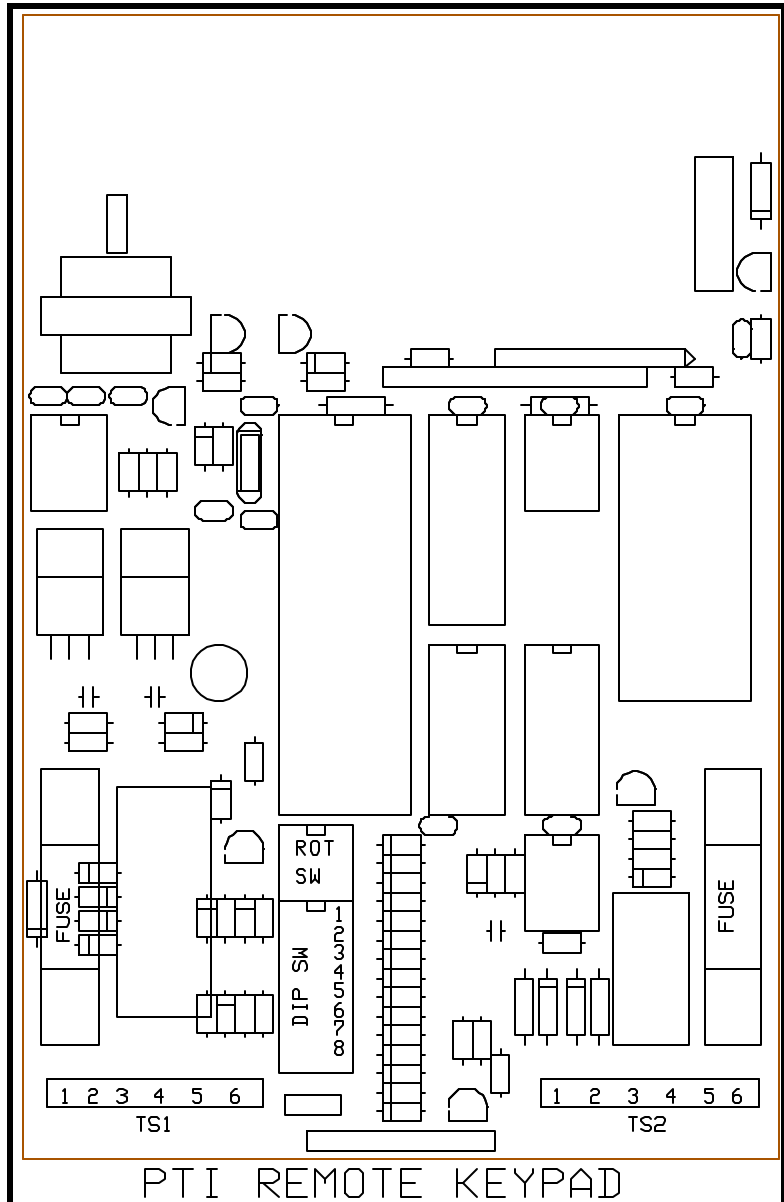

Figure Eleven

It is necessary to wire the following items to the remote keypad for proper operation:

- (1) Low voltage power and safety ground.
- (2) RS485 communication wires from the base unit.
- (3) Relay contact wires from the keypad relay to the entrance device.

Installation of wiring should proceed as follows:

- (1) Install the RS485 communication cable from the keypad to the base unit in the office. A 22 AWG shielded twisted pair with 22 AWG ground wire is best for this purpose. Terminate the wires as follows:

TS2, pin 1 - Red Wire - to red terminal of remote patch cable
TS2, pin 2 - ground - to white terminal of remote patch cable
TS2, pin 3 - Black Wire - to black terminal of remote patch cable

- (2) Install the relay contact wires to the entrance operator; both normally open and normally closed relay contacts are available on the following terminals:

TS2, pin 4 - Normally open relay contact
TS2, pin 5 - Relay common contact
TS2, pin 6 - Normally closed relay contact

Most electric gate operators require a normally open contact (pins 4 & 5). Some electric door strikes require a normally closed contact (pins 5 & 6). **WARNING: WIRING THE RELAY TO THE OPERATING DEVICE WILL INTRODUCE THE OPERATING DEVICE CONTROL VOLTAGE INTO THE REMOTE KEYPAD CABINET. THE INSTALLER MUST VERIFY THAT THIS DOES NOT CONSTITUTE A HIGH VOLTAGE! THE PTI KEYPAD IS NOT DESIGNED FOR THE PRESENCE OF HIGH VOLTAGE WITHIN THE KEYPAD CASE.**

- (3) Install low voltage power wiring into the keypad from the low voltage power transformer into TS1 as follows:

TS1, pin 1 - 12 VAC
TS1, pin 2 - 12 VAC
TS1, pin 3 - ground

The PTI remote keypad will operate on voltages from 12V to 24V AC or DC, however, 12VAC is recommended for best operation. If you purchased a complete PTI Falcon system, a 12VAC transformer is supplied with the system.

- (4) The PTI remote keypad has two optional input circuits for reading auxiliary switches.

Auxiliary input one is used to monitor an alarm switch input, which is typically used to detect forced opening of the gate or door controlled by the keypad. Auxiliary input two can be used to lock out the keypad from accepting codes based on a contact closure from an auxiliary device. This input is sometimes wired to a vehicle loop detector, which forces the customer to be in a vehicle before the keypad will allow access. If auxiliary contacts are used they should be dry contacts wired as follows:

- TS1, pin 4 - auxiliary contact one
- TS1, pin 5 - auxiliary contact common
- TS1, pin 6 - auxiliary contact two

Keypad Switches

The keypad switches must be properly set. The PTI Falcon system considers odd numbered keypads to be *entrance* keypads and even numbered keypads to be *exit* keypads. The first entrance keypad should be unit number one, the second unit number three, etc. Your exit keypads will then be units number two, four, etc. The unit number for each keypad is set with the red rotary switch. For unit numbers higher than nine, DIP switch number four should be turned on which adds ten to the rotary switch number. DIP switch number five may be used to add twenty to the rotary switch setting. It is possible to set the keypad number to any value from zero to thirty nine. Be aware that the PTI Falcon system reserves remote address zero for its own use, and a keypad set to be unit zero will not communicate with the base unit.

Finally, you must set the position of the eight DIP switches as needed for proper keypad operation. The switch functions are summarized in the following table:

Switch 1: OFF = echo code on display;	ON = no echo
Switch 2: OFF = disable auxiliary input one;	ON = enable
Switch 3: OFF = disable auxiliary input two;	ON = enable
Switch 4: OFF = 9600 baud communication;	ON = 1200
baud	
Switch 5: OFF = add zero to unit number;	ON = add ten
Switch 6: OFF = add zero to unit number;	ON = add twenty
Switch 7: OFF = not used;	ON = not used
Switch 8: OFF = high comm line impedance;	ON = low

When DIP switch one is turned on, an "X" will appear on the keypad display as each digit of the access code is entered, rather than the actual digit. This may be set to your individual preference.

The PTI Falcon uses a 1200 baud communication rate, therefore DIP switch four should be

set ON. The keypad only reads switch four at power up, so if you must change switch four, momentarily kill power to the keypad after it has been correctly set.

Switch eight when ON, places a communication line terminating resistor across the RS485 data leads. This switch should be turned ON if the keypad is the last keypad on the RS485 communication wire, otherwise set it OFF.

Figure Twelve illustrates a typical wiring scheme for a two keypad gate access system.

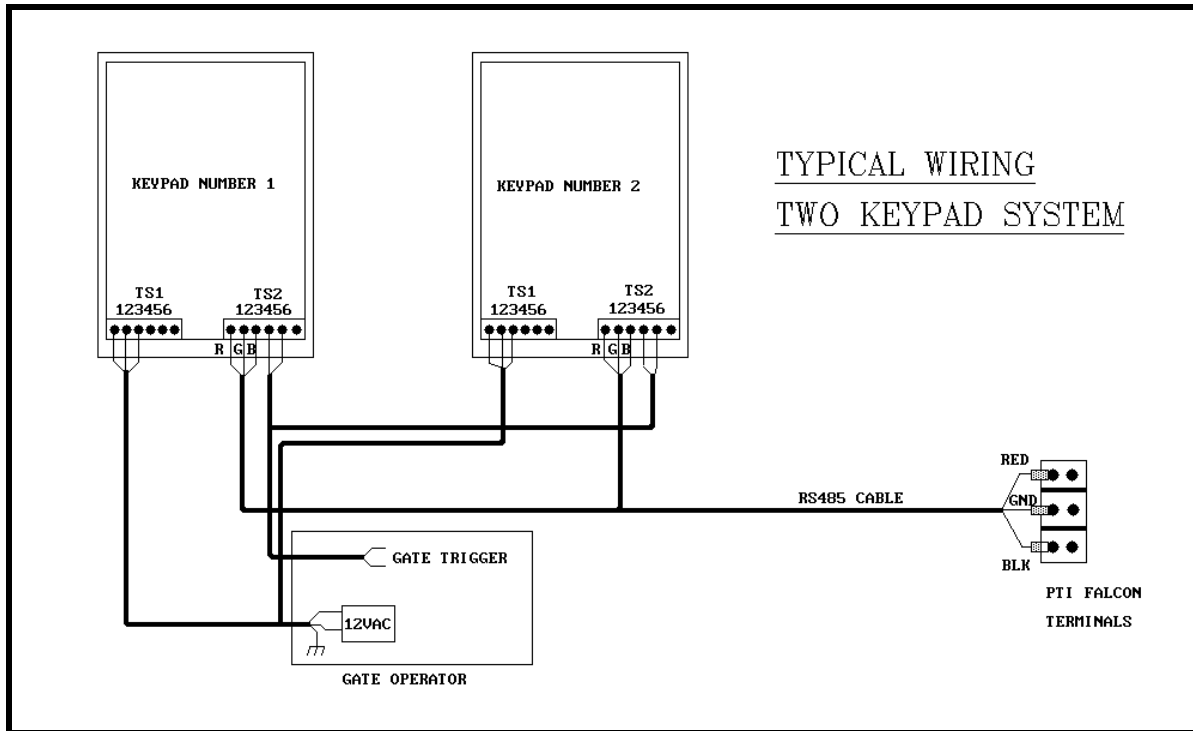

Figure Twelve

In this case, the twelve volt supply transformer for the keypad power has been located in the gate operator. In some installations, it may be more advantageous to locate this transformer in the office with the base unit.

With the RS485 communication scheme, a keypad can typically be located as far as four thousand feet from the base unit. As the wire length increases, a shielded twisted pair cable with ground wire becomes a necessity for proper operation.

Testing the Keypad

- (1) Test the liquid crystal display by applying power to the keypad. The default date and time of January 1, 1987 at 12:00 AM should appear on the display after power is applied. The PTI Falcon base unit transmits the correct date and time (the date and time shown on the base unit display) to the remote keypads once a minute, so the base unit may cause the date and time display to change to a different reading. Verify that the display backlight is working by pressing the "*" key on the keypad. The light should come on when the "*" key is pressed and the display will say "Please Enter Access Code". If you then press no keys for ten seconds, the date and time will return to the display. The light will turn off several seconds later. The light is difficult to see in daylight, so you may have to cover the display to be certain that it is working.
- (2) Test the keypad operation by pressing the "*" key. When the display says "Please Enter Access Code", press the digits "0-1-2-3-4-5-6-7". You should see each digit appear on the display as it is pressed (you will see an "X" for each digit if DIP switch #1 is set ON). The keypad will allow an eight digit code maximum, so press the "*" key several times to erase digits on the display and then press "8-9" to verify that all digits work. Then press the "#" key to transmit the code to the base unit. The display will say "Please Wait" after the "#" key is pressed. If your keypad is communicating with the PTI Falcon base unit, the "Please Wait" message may quickly be replaced by a response from the base unit such as "Sorry- Access Denied".
- (3) Check proper operation of the keypad backlights by cupping your hands tightly over the keypad and peering through your palms. This should block out enough ambient light for you to see the green lights illuminated behind the keypad.
- (4) Test the keypad rotary switch setting by pressing the "*" key. When the display says "Please Enter Access Code", press the "#" key before pressing any other key. The display will show "Unit Number = XX" where "XX" is the keypad number. The display will return to the date and time after ten seconds.
- (5) Test for communications with the base unit by turning on the base unit and entering the correct date and time into the base unit. The correct date and time should be sent to the keypad and appear in the display after it is changed in the base unit. This verifies communications from the base unit to the keypad. Test communications from the keypad to the base unit by entering an access code into the keypad and pressing the "#" key. If the keypad display responds with anything other than "Please Wait" before returning to the date and time, the keypad has successfully communicated with the base unit.

Individual Door Alarm Installation - Expandable

- (1) Find an appropriate location for the installation of each multiplexer box required for the

door alarm system. Each building must have its own mux box. Buildings with a large number of doors to alarm may have more than one mux box. Remember that although the mux boxes may look identical on the outside, some boxes may contain expansion boards and are configured to handle more doors than other boxes, so take care to match the correct box to each building. Although the box enclosures are rainproof and the boxes may be mounted outdoors, use indoor mounting if available. Above the entrance door to a building with hallway access makes an ideal location.

- (2) Mount each mux box by removing the door and sinking screws or bolts through the four box mounting holes into the wall. Take care not to damage the circuit board during the mounting process. If you must drill to mount the box, do not allow any metal fragments to become lodged on the circuit board.
- (3) Install the door to door wiring cable and door switches. Splice the door switch wires into the main cable as indicated in Figure Thirteen. Choose a different color wire for one side of each switch. Choose one wire as the common wire to the other side of all the switches on the cable.

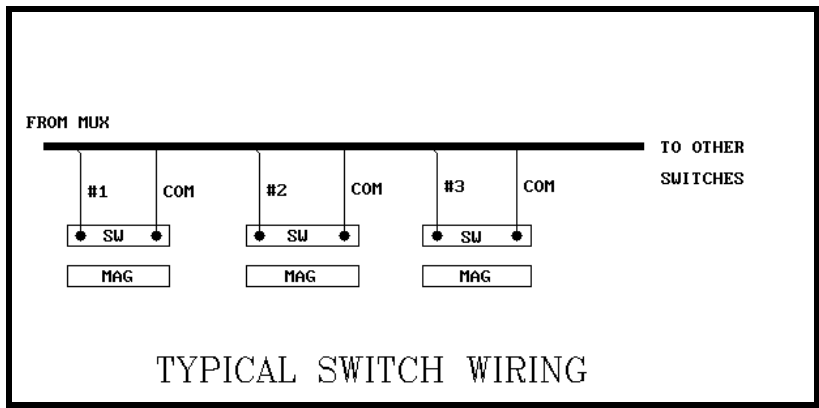

Figure Thirteen

There are several possible cable routing schemes. You may decide to route one door to door cable from the mux box, or several depending on the number of conductors in the cable used and the box location within the building. Remember that the maximum number of switches on one cable is equal to the number of conductors in the cable minus one. Telephone cable is commonly available in twenty four conductor or fifty conductor. One size will generally work better than the other depending on the number of doors and the mux box location.

Mount the magnet on the door and the switch parallel to the magnet approximately one inch away when the door is closed. Roll up style doors often require the use of a mounting bracket for the switch. The magnet may be either bolted to the door using the two mounting holes or glued using a panel adhesive.

- (4) Terminate the wires from the door to door wiring cable on the mux board depluggable terminal strips. Figure Fourteen illustrates the board layout. There must be one separate wire from each door switch and a common wire from all door switches. Terminate the separate wires on the three sixteen position terminal strips, beginning with position #1 on the bottom left. The common wire or wires may be terminated on any of the three four-position terminal strips.

Mux Box Switches

There are four red rotary switches on the master mux board. The top two switches allow you to set the board for the number of doors actually wired to the board. Dial the two digit number into the switches using a small screwdriver. The switches are read from bottom to top. For example, thirty seven doors would require the top switch to be set to **seven** and the switch below it to be set to **three**. If the board controls more than ninety nine doors, setting DIP switch #1 to the **ON** position will add one hundred to the two digit number of doors dialed into the red rotary switches.

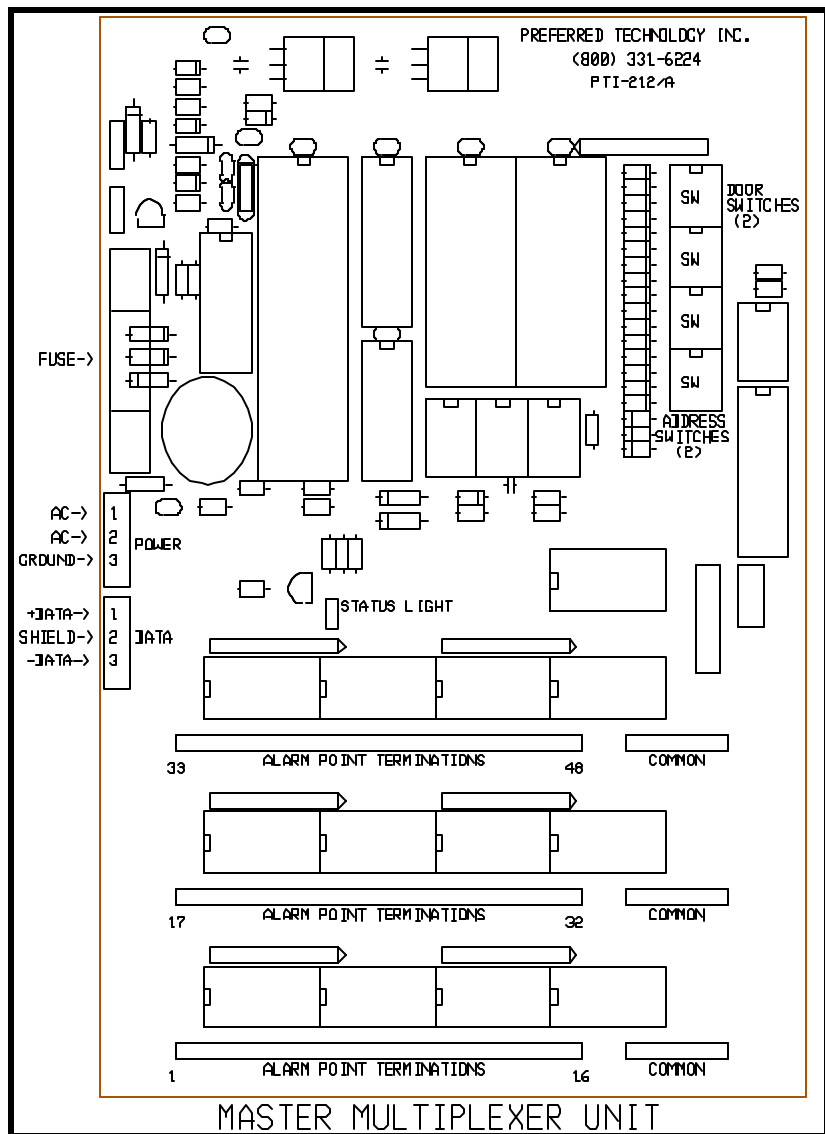

Figure Fourteen

Set the other two red rotary switches to the unit number desired for the mux box. The boxes may be numbered in any order as long as each box has a unique unit number that is not the same as any other mux box or keypad. It is typical to begin numbering the mux boxes at one higher than the last remote keypad number. For example, if there are two gate access keypads numbered one and two, then the mux boxes will be numbered three, four, five, etc. These red rotary switches are also read bottom to top, so a remote number

of three will require the bottom red rotary switch to be set to **zero** and the one above it to **three**.

Set the remaining DIP switches as summarized in the following table:

Switch 1:	OFF = less than 100 doors;	ON = more than 100
Switch 2:	OFF = 9600 Baud communication;	ON = 1200 baud
Switch 3:	OFF = normal operation;	ON = PTI test mode
Switch 4:	OFF = high comm line impedance;	ON = low

The PTI Falcon communicates at 1200 baud, so DIP switch Two must be set to the **ON** position before applying power to the mux box. Switch Three should always be set **OFF**. Switch Four should be set **ON** if the box is the last device on the RS485 communication wire, otherwise it should be set **OFF**.

Install the communication and power wiring to the mux boxes. Communications and 12 VAC power may be run through the same cable if a cable with two individually shielded twisted pairs is used. 22 AWG is sufficient wire gauge for most applications. Figure Fifteen illustrates a typical hookup for power and communication wiring.

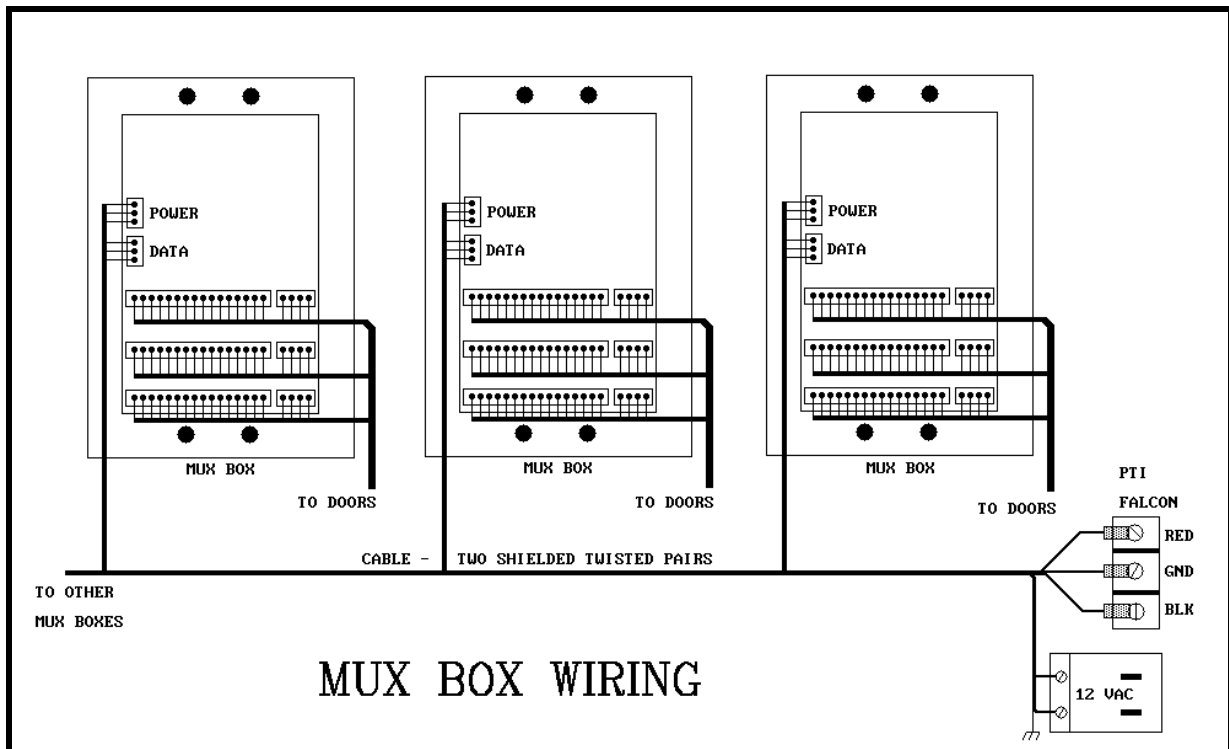

Figure Fifteen

Individual Door Alarm Installation - Single Wire

- (1) Find an appropriate location for the installation of each DCU box required for the door alarm system. Each building should have its own DCU box. Large buildings having more than one hundred units may require more than one DCU box. Although the DCU enclosures are rainproof and the boxes may be mounted outdoors, use indoor mounting if available. Above the entrance door to a building with hallway access makes an ideal location.
- (2) Mount each DCU box by removing the door and sinking screws or bolts through the four box mounting holes into the wall. Take care not to damage the circuit board during the mounting process. If you must drill to mount the box, do not allow metal fragments to become lodged on the circuit board.
- (3) Install single gang electrical junction boxes in each unit at a convenient location above the door near where the door switch will be mounted. Route the three conductor cable from the DCU box to the first single gang box and make a six inch loop of slack wire in the junction box. Continue through the second and all other junction boxes in order making the same six inch loop of slack wire in each junction box. Route the wire in whatever order allows the total wire length to be kept to a minimum.

Mount the magnet on each door and the switch parallel to the magnet approximately one inch away when the door is closed. Roll up style doors often require the use of a mounting bracket for the switch. The magnet may be either bolted to the door using the two mounting holes or glued using a panel adhesive.

- (4) Install the DIU board at each door with the connections as shown in Figure Sixteen. Wire terminations to the DIU board require that the installer use a crimping tool to connect a 0.187 inch "quick connect" to each wire so that it may be plugged on to the DIU circuit board. There are two connection points on the end of the DIU board to which the door switch should be connected. There are then three connection points remaining on each side of the board for the three conductor door to door wire. The side labeled "Toward DCU" should hook to the wire running toward the DCU box. The side labeled "From Doors" should hook to the wire running to the next farther unit from thr DCU box.

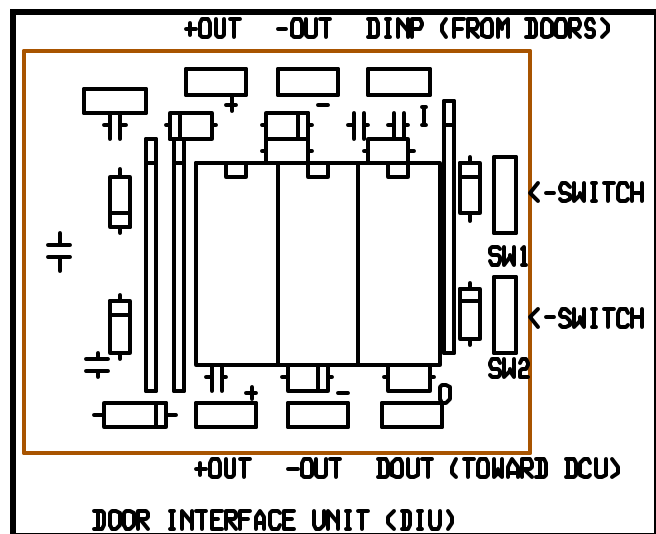

Figure Sixteen

Three conductor cable typically contains a red conductor, a black conductor, and a white conductor. The colors should be hooked up

as follows:

TOWARD DCU

Red: +OUT
Black: -OUT
White: DOUT

AWAY FROM DCU

Red: +OUT
Black: -OUT
White: DINP

The two conductor switch wire may be hooked up in either order to the two end connection points.

- (5) Terminate the three conductor door to door wire on the bottom right terminal strip of the DCU board as shown in Figure Seventeen. This terminal strip is numbered one through three, left to right.

Be careful to terminate the white wire under screw number one, the red wire under screw number two, and the black wire under screw number three.

- (6) Install the communication wiring to the DCU boxes. The RS485 communication wire should be a 22 gauge shielded twisted pair for best results. This type of cable will contain a red conductor, a bare shield wire, and a black conductor. The red wire should be hooked to the DATA+ terminal, the bare wire to the SHIELD terminal, and the black wire to the DATA- terminal. The terminal locations are indicated in Figure Seventeen. The RS485 communication cable will connect all keypads and DCU boxes in parallel to the PTI Falcon base unit.

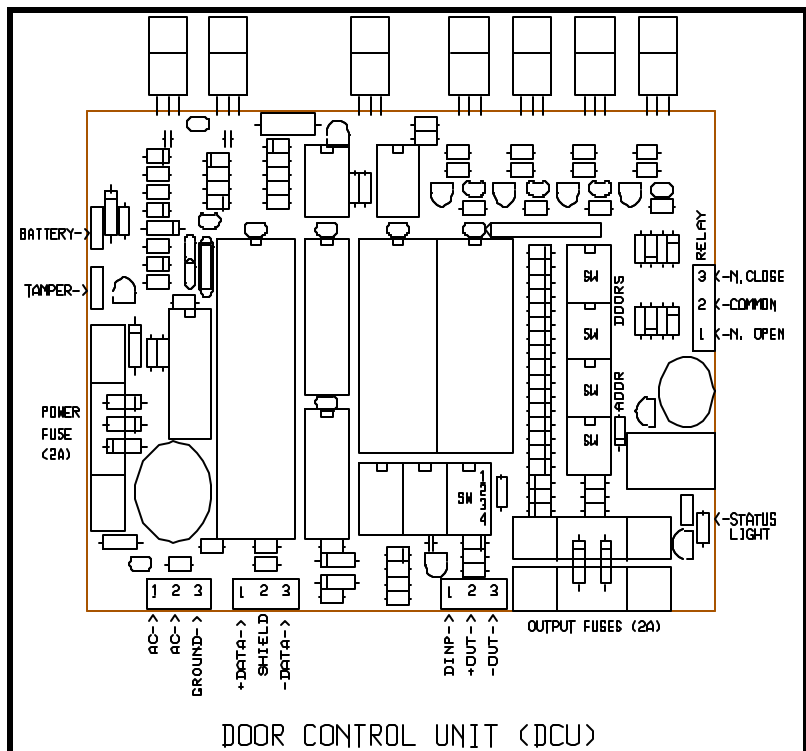

Figure Seventeen

Mux Box Switches

There are four red rotary switches on the master DCU board. The top two switches are

used to set the number of doors actually wired to the DCU board. Dial the two digit number into the switches using a small screwdriver. The switches are read from bottom to top. For example, thirty seven doors would require that the top switch be set to **seven** and the bottom switch be set to **three**. If the board controls more than ninety nine doors, setting DIP switch #1 to the **ON** position will add one hundred to the two digit number of doors dialed into the red rotary switches. **Failure to set the switches to the correct number of doors controlled by the DCU box will generate erroneous readings of the door switches.**

Set the other two red rotary switches to the unit number desired for the DCU box. The boxes may be numbered in any order as long as each box has a unique unit number that is not the same as any other box or keypad. It is typical to begin numbering the DCU boxes at one higher than the last remote keypad number. These read rotary switches are also read from bottom to top, so a remote unit number of three will require that the bottom red rotary switch be set to **zero** and the one above it to **three**.

Set the remaining DIP switches as summarized in the following table:

Switch 1:	OFF = less than 100 doors;	ON = more than 100
Switch 2:	OFF = 9600 Baud communication;	ON = 1200 baud
Switch 3:	OFF = normal operation;	ON = PTI test mode
Switch 4:	OFF = high comm line impedance;	ON = low

The PTI Falcon communicates at 1200 baud, so DIP switch Two must be set to the **ON** position before applying power to the mux box. Switch Three should always be set **OFF**. Switch Four should be set **ON** if the box is the last device on the RS485 communication wire, otherwise it should be set **OFF**.

Testing the Alarm Wiring

The PTI alarm multiplexer box contains a small red light emitting diode (LED) on the circuit board. This light is used for diagnostics and may be used to check your alarm switch

Note: The term "mux box" is used in this section to refer to either the PTI expandable door alarm mux box or the PTI single wire DCU box.

wiring. It is not necessary to have the PTI Falcon base unit installed or operational for this test. It is only necessary that the alarm switch wiring be installed and power applied to the mux box.

The LED light will blink a long blink followed by three groups of blinks with pauses in between each group. A group of blinks represents one digit of a three digit number. For example, the number "257" would appear as follows:

long blink	signifies start of number
pause	
two blinks	digit "2"
pause	
five blinks	digit "5"
pause	
seven blinks	digit "7"
pause	
long blink	start of new cycle

A small number which does not require three digits will have leading zeros appended and three digits will still be blinked. A zero is represented by a half width blink. For example the number three will be:

long blink	start of number
pause	
half width blink	digit "0"
pause	
half width blink	digit "0"
pause	
three blinks	digit "3"
pause	
long blink	start of next number

It may take a little practice to discern the difference between the digit "0" and the digit "1", but with practice it is quite easy.

With an understanding of the above method of blinking a three digit number with the LED, proceed to test the installation of the mux box as follows:

- (1) After power is first applied to the mux box, the LED will blink out the rotary switch settings until the first alarm switch changes state (a door is opened or closed). This includes the tamper switch on the mux box, so remove the mux box door before applying power and performing this test. The LED will alternate between blinking the remote unit number of the mux box (the bottom two rotary switches) and the number of doors wired to the box (the top two rotary switches). Since there are only two switches blinked at a time, a leading zero will be appended to form a three digit number. Verify that the rotary switches are properly set by counting the LED blinks to see that they match the switch settings.

- (2) After verifying the rotary switch settings, trip the mux box tamper switch with your hand. On the next cycle, the LED should blink "0-0-0", since the tamper switch is considered to be door number zero.
- (3) You may then test the other door switches by opening or closing each door that you wish to test. The LED will always blink the number of the last door opened or closed as a three digit number. Remember that this is the number of the position in the terminal strip to which the door is wired, not your actual rental unit number. The PTI Falcon base unit will later translate the wire position number into your actual unit number. Continue testing until proper operation of all door switches has been verified.

Testing Mux Box Communications

To test communications with the alarm multiplexer box, your PTI Falcon base unit must be installed and operational, and your communication wiring to the alarm mux box must be in place. Test communications as follows:

- (1) Check that all wiring is in place, all switches properly set, and all cables plugged in to the back of the PTI Falcon base unit. Apply power to the alarm mux boxes.
- (2) Load the printer with paper according to the instructions in the printer manual and apply power to the printer.
- (3) Apply power to the PTI Falcon base unit. After several seconds, the PTI Falcon will print on the printer "Comm On - Remote XX" along with the date and time as shown on the base unit display, where "XX" is the remote number for which communications has been logged on. One line will be printed on the printer for each remote device. If communications is lost to a remote device after being logged on, the message "Comm Off - Remote XX" along with the date and time will be logged on the printer.

Base Unit Installation

Follow the following steps for installation of the PTI Falcon base unit:

- (1) Locate the base unit at a readily accessible position where there is power available. Plug the AC power cord into the back of the base unit. **Do not plug the power cord into a wall outlet yet.**
- (2) Locate the printer at a readily accessible position where there is power available. Install the printer cable between the base unit and the printer by plugging the twenty five pin connector in at each end. Tighten the cable retaining screws using a small screwdriver. Install the printer ribbon and paper according to the instructions in the printer manual **before plugging the printer power cord into a wall outlet.**

- (3) Make certain that the communications wiring from the remote keypads and door alarm multiplexers has been properly terminated on the remote patch cord and that the wires are in the correct order on the patch cord terminal block. **Do not plug the patch cord into the back of the PTI Falcon until after the AC power has been applied.** Plugging the patch cord into the base unit will cause the base unit to be powered from its internal rechargeable batteries. These batteries may not be fully charged at this time and could cause the base unit to receive only partial power.
- (4) If you have ordered the optional computer interface for the PTI Falcon, install the computer interface cable between the base unit and your personal computer. If both ends of the cable have a nine pin connector, check the labels on the connectors to determine the cable direction.
- (5) Plug the base unit power cord into a properly grounded outlet. **WARNING: SHOCK HAZARD! NEVER OPERATE THE PTI FALCON BASE UNIT FROM AN UNGROUNDED OUTLET OR USE A THREE TO TWO WIRE CONVERSION ADAPTER WITH THE PTI FALCON!** If your office is not equipped with safety grounded outlets, consult a licensed electrician to have a properly grounded outlet installed.
- (6) Turn on the AC power switch on the rear of the base unit. The default date and time should appear on the display. Then install the remote patch cord in the connector on the rear of the base unit and tighten the retaining screws. This will not only complete the connection to the remote devices, but will allow the internal batteries to begin to charge. The batteries may require forty eight hours of initial operation of the base unit before being fully charged.
- (7) Apply power to all remote keypads and door alarm boxes and begin testing.

Programming

General Information

The PTI Falcon uses a menu driven programming system which is easily mastered. Individual programming commands are accessed by *function number*. There are a total of twenty function numbers listed on the programming guide sticker on the front of the base unit. A copy of the programming guide sticker is given here for reference. To access a programming function, proceed as follows:

Press "*".
Enter the Number
Press "#".

If the programming guide sticker is unavailable, it is possible to scroll through the available function numbers on the PTI Falcon display. This is accomplished as follows:

Press "*". (The display will read "Function? ")
Press "#". (The display will move to Function #1)

If you wish to select a Function other than Number One:

Press "*". (The display will move to Function #2)

Continue to press "*" until the desired Function Number is displayed, then:

Press "#". (The display will begin the selected Function)

BASIC KEYPAD INSTRUCTIONS

PRESS * KEY, FUNCTION NUMBER, # KEY
OR PRESS * THEN # FOR HELP

- 1 - SET TIME/DATE
- 2 - SET BUS.HOURS
- 3 - SET HOLIDAYS
- 4 - SET BLDG SIZES
- 5 - ADD NEW UNIT
- 6 - SUSPEND UNIT
- 7 - RELEASE UNIT
- 8 - REMOVE UNIT
- 9 - SET 24HR UNIT
- 10 - SAVE ON TAPE
- 11 - LOAD FROM TAPE
- 12 - PRINT REPORTS
- 13 - ADJ. CONTRAST
- 14 - OPEN ENTRANCE
- 15 - SET MASTER CODE

(DOOR ALARMS ONLY)

- 16 - DOORS ON/OFF (The display will read "Function? ")
- 17 - CLEAR ALARMS
- 18 - READ ALL DOORS
- 19 - UNKID DOOR UNIT (The display will begin the selected Function)
- 20 - SET RELAY TIMES

PTI Access Controls - Summerville, SC
(800) 331-6224 · (803) 875-4994

If you scroll through all function numbers without making a selection, the display will read "Setup Done?". To scroll through the functions again, press "*" for NO, or if you are finished, press "#" for YES.

Programming a New Installation

In order to program a new installation, you must perform the following steps:

- (1) Set the correct time and date (Function #1)
- (2) Set the property business hours (Function #2)
- (3) Set the building sizes for the property (Function #4)
- (4) Add new units as required (Function #5)

Optional programming steps that may be necessary after completing the above steps are as follows:

- (1) Set holidays that are to be recognized (Function #3)
- (2) Mark any units that need 24 Hour access (Function #9)
- (3) Suspend access for any overdue customers (Function #6)

Programming details for each function number are given in the sections of the manual that follow.

**Function #1 -
Set Time/Date?**

Function #1 - Set Time/Date is used to enter the correct time and date into the PTI Falcon. The date is entered in Month-Day-Year format, with two digits required for each. Even though no punctuation marks (slashes) are entered from the keypad, the PTI Falcon will provided them on the display. For example, to set the date to January 9, 1991, you must enter **01/09/91**. Note that years from 85-99 refer to 1985-1999, and years from 00-84 refer to 2000-2084.

In the example at the right, the bold face type has been entered to change the date from the initial setting of 01/01/87 to 01/09/91. Press "#" to set the new date.

Enter 01/01/87
Date: **01/09/91**

After entering the correct date, you may enter the correct time. The time is entered in Hour-Minute format, with two digits required for each. Even though no punctuation marks (colon) are entered from the keypad, the PTI Falcon will provide them on the display.

For example, to set the time to 3:00 PM, you must enter **03:00** from the keypad. The display will then alternately blink between 03:00 **AM** and 03:00 **PM**. Press the "#" key when **PM** is displayed to select 3:00 PM. The example at the right indicates the screen appearance when entering the time.

Enter 12:00 AM
Time: **03:00 PM**

At times, you may wish to change only the time without affecting the date, or only the date without affecting the time. This is possible by pressing the "*" key as the first key entered when you are asked to enter a new date or time. If the "*" key is pressed first, the entry will be skipped (and thus remain at its present value) and the PTI Falcon will proceed to the next entry.

Whenever the date or time is changed, the PTI Falcon will recalculate the proper day of the week. The PTI Falcon display will indicate the day of the week, the correct date, and the correct time on the display when no other function is being performed. An example of the display appearance is shown at the right.

Wed, 01/01/91
03:00 PM

**Function #2 -
Set Bus. Hours?**

Function #2 - Set Business Hours is used to set the normal access hours that you wish to allow for your customers. Business hours are specified with both an **Open Time** and a **Close Time**. Open and Close times may be specified separately for weekdays, Saturdays, Sundays, and Holidays. Each time is entered a format similar to that used for setting the time with Function Number One. For example:

On weekdays, allow normal access from 8:00 AM to 5:00 PM.

Weekday 12:00
AM
Open: **08:00** AM

Weekday 12:00
AM
Close: **05:00** PM

On Saturdays, allow normal access from 9:00 AM to 6:00 PM.

Sat 12:00 AM
Open: **09:00** AM

Sat 12:00 AM
Close: **06:00** PM

On Sundays, allow normal access from 1:00 PM to 6:00 PM.

Sun 12:00
AM
Open: **01:00** PM

Sun 12:00
AM
Close: **06:00** PM

On Holidays, do not allow normal access.

Holiday 12:00
AM
Open: **12:00** AM

Holiday 12:00
AM
Close: **12:00** AM

As in Function One, select between AM and PM by pushing the "#" key when the desired setting appears on the screen. Normally, the Open time for a given day occurs before the Close time. If you specify a Close time which is earlier in the day than the Open time, the PTI Falcon will allow normal access all hours of the day except the time between the Close time and the Open time.

In this example, the PTI Falcon will allow access at all hours on Saturday except 8:00 AM to 11:00 AM.

Saturday 12:00
AM
Open: **11:00** AM

Saturday 12:00
AM
Close: **08:00** AM

**Function #3 -
Set Holidays?**

Function #3 - Set Holidays allows up to thirty two holidays to be specified in advance by date. On these days, the PTI Falcon will use the holiday access hours rather than the normal weekday, Saturday, or Sunday access hours. Each holiday is assigned a consecutive holiday number in the range of one to thirty two. The holidays do not have to be assigned in any particular order.

For example, to set holiday number three to be July 4, 1991, enter **3** for the holiday number as shown.

Holiday # = **3**

Then, enter **07/04/91** for the holiday date as indicated. On July 4, 1991 the programmed holiday hours will be observed by the PTI Falcon.

Holiday	00/00/00
Date:	07/04/91

If you need to change a holiday, follow the same procedure and simply enter a new date for the holiday. The PTI Falcon display will always indicate the present setting for the holiday date on the top line of the display. Holidays which have never been programmed will appear as **00/00/00**. It is not necessary to remove a holiday which has already passed, because the date will never occur again anyway. If you wish to cancel a holiday that has not yet occurred, you may reset the holiday date to 00/00/00 or to any date which has already passed. Remember that the two digit year for any date in the PTI Falcon refers to the twentieth century if the year is eighty five or higher, and the twenty first century for years zero through eighty four.

**Function #4 -
Set Bldg Sizes?**

Function #4 - Set Building Sizes allows you to classify your customers into Building groups. A user of the PTI Falcon is identified by the combination of his Building number and his Unit number. This function allows you to specify the number of units allowed in each building. Units will be numbered in each building from one to the specified building size. If the units in your facility are consecutively numbered throughout the facility or if the building number is inherent in the unit number, you may wish to classify all customers into "Building 1" and not use separate building numbers.

As an example, suppose a facility has 300 units in three buildings as follows:

- Building One: 75 units numbered 100-175
- Building Two: 75 units numbered 200-275
- Building Three: 50 units numbered 300-350

Then the building number is inherent in the unit number, and the largest unit number is 350 (even though there are only 300 units).

For the PTI Falcon, classify all units into one building group as follows:

Building (1-32)
Number: **1**

Then set the building size to match the largest unit number:

Bldg 01: 0000
New Size: **350**

Now units on the facility will be numbered from 1-350 (even though some numbers are not used) within building group 1. Even though this allows access codes to be specified for all units that exist, it is typical to specify one extra building group of a small size (typically 10) to which management access codes can be assigned.

Function #5 - Add New Unit?

Function #5 - Add New Unit allows you to add a new unit into the PTI Falcon memory and assign it an access code. If PTI door alarms are in use, you will also specify the physical manner in which the alarm switch from the unit is wired. Proceed as follows:

Enter the Building Number for the unit that you wish to assign. The building size must have been previously set with Function #4.

Building (1-32)
Number: **1**

Enter the Unit Number for the unit that you wish to assign. The unit number must be in the range of one to the size specified for the building.

Unit (1-Size)
Number: **150**

Enter the Access Code for the unit. Access codes may be up to eight digits in length. Leading zeros will be ignored. This is the number that the user must enter at the remote access keypads to gain entry.

Enter Access
Code: **12345678**

The following two steps will only need to be performed if you have PTI door alarms in operation:

Enter the control unit number to which the door is wired. This number must be provided by the alarm system installer and represents the number of the alarm multiplexer box to which the unit is wired.

Control
Unit = **3**

Enter the door number for the unit. This is the physical terminal number for the alarm switch wire within the multiplexer box. This number must also be provided by the alarm system installer.

Door
Number = **37**

After specifying all data for a unit, the screen will indicate "**Do More?**". If you wish to immediately enter data for another unit, press "#" for YES and you will go back to the first step above, otherwise press "*" for NO.

Do More?

When adding a new unit, if you select a Building and Unit number that already exists in the PTI Falcon memory, the display will indicate the "**Error - Already Exists**" message for a few seconds and then return to allow you to enter a different Building and Unit number.

Error -
Already Exists

Duplicate Access Codes

Under most circumstances, the access code for a single unit will be unique and assigned only to one unit. You may at times, however, have customers that rent multiple units and do not wish to remember a separate access code for each unit. This is of little consequence since you can always assign an access code to only his first unit, unless a door alarm system is in operation. In this case, the PTI Falcon must be able to recognize all units that belong to a single customer so that when he enters the property, the alarms on all of his units can be disarmed.

This is accomplished by allowing the same access code to be assigned to multiple units. To do this, enter data for the first unit normally, and then enter data for the second unit. Upon entering the same access code for the second unit, a warning message will be displayed as illustrated to tell you that you are duplicating an access code. The screen will indicate the building and unit number that already use the code. After displaying the warning for a few seconds, the screen will change and ask you if you wish to save the code anyway. Press "#" for YES to assign the duplicate code to a second unit, or press "*" for NO if you do not wish to assign the duplicate code. If you press "*", you will return to the access code entry screen so that you may assign the unit a different access code.

Warning-Used By:
Bldg 01, Un 0002

Save Anyway?

The above procedure may be repeated as many times as necessary to assign the same access code to all units which are assigned to a single individual.

Function #6 -
Suspend Unit?

Function #6 - Suspend Unit is used to temporarily block access for a unit. No data on the unit is lost, but if the user attempts to enter the property, he is denied access. The attempted entry will be logged on the printer as part of the access log. The customer will be informed on the display of the remote keypad that his access has been suspended.

Enter the Building Number of the unit that you wish to lock out.

Building (1-32)
Number: **1**

Enter the Unit number of the unit that you wish to lock out.

Unit (1-Size)
Number: **150**

The screen will then say "Do More?". If you wish to lock out other access codes, press "#" and you will return to the first step above, otherwise press "*".

Do More?

If you enter either a Building Number or a Unit Number that does not exist, the screen will indicate an "Error - Nonexistent" message for a few seconds and then return to allow you to re-enter the Building or Unit number.

Error -
Nonexistent

Function 7 -
Release Unit?

Function #7 - Release Unit is the opposite of Function Six, that is it allows a unit that has been previously suspended to once again have access to the property.

Enter the Building Number of the Unit to released from suspension.

Building (1-32)
Number: **1**

Enter the Unit Number of the Unit to be released from suspension.

Unit (1-Size)
Number: **150**

If you wish to release other units, press "#" and you will return to the first step above, otherwise press "*" to indicate completion.

Do More?

If you select a Building or Unit number that does not exist, the screen will indicate an "**Error - Nonexistent**" message and then return to allow you to enter the correct building or unit number.

Function 8 -
Remove Unit?

Function #8 - Remove Unit is the opposite of Function #5. It performs the complete deletion of all data for a Unit. This function should be used to delete an access code when the customer has permanently left the property and the unit is open for rental by another customer.

Enter the Building Number for the Unit to be deleted.

Building (1-32)
Number: 1

Enter the Unit Number for the Unit to be deleted.

Unit (1-Size)
Number: 150

If there are other units that you need to delete, press "#" for YES, otherwise press "*" for NO.

Do More?

If you enter a Building or Unit number that does not exist, the screen will indicate "**Error - Nonexistent**" and then return to allow you to enter the correct Building or Unit number.

Function #9 -
Set 24hr Unit?

Function #9 - Set 24hr Unit allows you to mark individual units to have twenty four hour access to the property. Units with twenty four hour access are allowed to enter the property at any time, regardless of the programmed business hours for the property. Access may still be denied if it has been suspended using Function #6.

Enter the Building Number for the Unit to be given twenty four hour access.

Building (1-32)
Number: **1**

Enter the Unit number for the Unit to be given twenty four hour access.

Unit (1-Size)
Number: **150**

Press "#" for YES to give the unit twenty four hour access, or press "*" for NO to deny the unit twenty four hour access.

24Hr Access
(Y/N)?

If a Building or Unit number is entered that does not exist, the screen will display "**Error - Nonexistent**" for a few seconds and then return to allow you to enter the correct Building or Unit number.

Function #10 -
Save on Tape?

Function #10 - Save on Tape allows you to record the contents of the system memory on a standard audio cassette recorder for memory backup purposes. This unique feature allows you to separate your customer data from the machine as well as make multiple backup copies for enhanced reliability. Backup tapes can be made even after the AC power has failed while operating from internal battery power. Backup tapes should be made on a regular basis, anytime that significant changes have been made to the customer data in the machine.

Prior to selecting Function #10, plug the audio patch cord into the jack on the front of the PTI Falcon. Plug the other end into the **microphone** jack of the tape recorder. After selecting Function #10, the display will instruct you to "**Start Tape, Hit #**". Push the **record** button and then press the "#" key.

Start Tape,
Hit #

The display will then indicate "**** Saving ****". This display will stay on for about ten seconds and then will begin to blink on and off. When the tape is almost complete, the display will stop blinking and will be on constantly again for a few seconds. The display will then return to the current date and time.

** Saving **

When the date and time has returned to the display, the tape is complete and you may stop the recorder, rewind the tape, and remove it for safe keeping. Before storing the tape, it is suggested that you verify the tape contents by loading the tape back to the PTI Falcon using Function #11. The PTI Falcon verifies the integrity of each section of the tape before loading it, so you cannot alter the contents of memory if your tape did not properly record.

You may wish to listen to the sound of a good tape out loud and become accustomed to the sound. This will help you to identify any future problems with tape quality.

Function #11 -
Load from Tape?

Function #11 - Load from Tape allows you to load the data from a previously saved backup tape into the PTI Falcon memory. This will restore the memory to the exact condition it was in when the tape was made. Any changes made to the memory after the backup tape was made will not be restored and must be made again by hand.

Before beginning Function #11, plug the audio patch cord into the jack on the front of the PTI Falcon. Plug the other end of the cord into the **Earphone** jack of the tape recorder. Insert the backup tape and make certain that it is fully rewound. Make certain that the volume control is set from mid to three quarter range. After selecting Function #11, the display will read "**Start Tape, Hit #**". Press the "#" key and then push the **Play** button on the tape recorder.

Start Tape,
Hit #

The display will now read "*** **Loading** ***". This will remain on constantly for about ten seconds and then will begin to blink on and off as the tape data is loaded into memory. Near the end of the recording, the display will come on constantly for a few seconds and then will indicate "**Load Done**" and return to the date and time. The tape is now fully loaded, so stop the recorder, rewind the tape, and return it to safe keeping.

** Loading **

If the "*** **Loading** ***" display does not begin to blink on and off as described, your tape is not being read. This can happen if the tape is not fully rewound before playing or if you start playing the tape too long before pushing the "#" key and miss the first part of the tape. The PTI Falcon must synchronize itself to the tape at the very beginning of the tape or it cannot read any of the tape.

If while reading a tape, The PTI Falcon encounters an area of the tape it cannot read, it will display "**Tape Read Error**" for a few seconds and then return to the date and time. This can be caused by a defective tape or a tape that gets wrinkled. Low batteries in the recorder can also cause tape read errors, even when a tape is perfectly good.

Tape Read Error

Function #12 -
Print Report?

Function #12 - Print Reports is used to generate reports on the printer with the PTI Falcon. The report types are:

- 1: All - a report of all customers and their access codes; twenty four hour codes are marked with a "*"; units that are on-site are marked with an "S"; units with suspended access are labeled "On Hold". Systems with PTI door alarms will also print the door control unit number and door terminal number for each unit.
- 2: Hold - a report similar to type 1 except only units with suspended access are printed.
- 3: Vacant - a report of all units for which no access code has been assigned.
- 4: Open - a report similar to type 1 except only units with open doors are printed; this report is available only on units with PTI door alarms.
- 5: Stop - selecting this report type stops a report already in progress from further printing.

After selecting Function #12, the screen will appear as indicated. Select the report type by pressing a single digit 1 through 5. If you select 1,2,3, or 4 the PTI Falcon will begin printing the selected report and the PTI Falcon display will return to displaying the date and time. After a report is in progress, selecting number 5 will cause the PTI Falcon to cease sending characters to the printer and return to displaying the date and time. Even though the PTI Falcon has stopped sending data to the printer, the printer will continue to print until all data previously sent has been printed. This may make it initially appear as if the report was not canceled, but if you wait a few seconds the printer should stop.

All, Hold, Vacant,
Open, Stop (1-5)?

Note that the PTI Falcon allows you to perform other Functions with the keypad while a report is being printed. If you perform a Function that changes the customer data while a report is being printed, the new change may or may not appear in the printed report.

Function #13 -
Adjust Contrast

Function #13 - Adjust Contrast allows you to adjust the contrast of the Liquid Crystal Display (LCD) on the PTI Falcon base unit. You can either darken or lighten the display contrast.

After selecting Function #13, the PTI Falcon display will appear as illustrated. Each press of the "*" key will darken the contrast by one step; each press of the "#" key will lighten the contrast by one step. Set the contrast to your personal taste and then stop pressing any keys on the keyboard. After ten seconds of no keyboard activity, the PTI Falcon will return to the date and time display.

*=darker
#=lighter

A similar adjustment is available for the displays on the remote keypads; see Function #15 for details.

Function #14 -
Open Entrance

Function #14 - Open Entrance can be used to manually open your gate or entrance from the keypad on the PTI Falcon base unit. Each PTI Falcon remote keypad contains a relay which the installer has wired to the entrance motor or lock. This Function allows you to manually trigger the relay in any remote device in order to open the entrance to which the remote device is wired. If you have PTI door alarms in use, you also have a relay installed in the PTI Falcon base unit. This relay is typically used to trigger your alarm siren. This Function also allows you to trigger the relay in the base unit, which can be used to test your siren.

After selecting Function #14, the display will ask you for the number of the remote device that you wish to trigger. Enter the number and press "#". The remote relay will be triggered and the PTI Falcon will return to the date and time display.

Trigger Remote
Number: 0

Your installer should tell you the remote number which will trigger each entrance or exit device that you have on the property. Remote number "0" refers to the relay within the PTI Falcon base unit.

Use of Function #14 to trigger a relay is logged on the printer and becomes a part of the access log for the property.

Function #15 -
Set Master Code?

Function #15 - Set Master Code is used to enter a master code into the PTI Falcon base unit memory. The master code will not open any entrance and must be unique, it cannot be assigned to a customer as it will not allow access. When the master code is entered into a remote keypad, the keypad display will enter the contrast adjustment procedure. Contrast adjustment then proceeds in a fashion similar to that in Function #13 for the base unit display.

After selecting Function #15, the display will appear as indicated. Enter the master code of your choice and press "#". The PTI Falcon will save the master code in memory and return to the date and time display. The master code may be up to eight digits in length like any other access code. Verify operation of the master code by entering the code at a remote keypad. The remote keypad display will go into the contrast adjustment procedure.

Enter Master
Code: **87654321**

Entry of the master code at a remote keypad will be logged on the printer as part of the access log, but the entrance cannot be opened with the master code.

Function #16 -
Door On/Off?

Function #16 - Door On/Off is available only on systems with PTI door alarms. It allows you to individually turn on or off the alarm for a unit. This is sometimes necessary if an alarm switch breaks, or a customer simply does not want his unit alarmed.

Enter the Building number for the unit that you wish to turn on or off.

Building (1-32)
Number: **1**

Enter the Unit number for the unit that you wish to turn on or off.

Unit (1-Size)
Number: **150**

If door printing is presently **on** for the unit, the display will indicate so. Press "#" to turn door printing off for the unit or press "*" to leave it on.

Door Print On
Turn Off?

If door printing is presently **off** for the unit, the display will indicate so. Press "#" to turn door printing on for the unit or press "*" to leave it off.

Door Print Off
Turn On?

If you select a Building or Unit number that does not exist in the PTI Falcon memory, an "**Error - Nonexistent**" message will appear for a few seconds and then the display will return to allow you to enter the correct Building or Unit number.

Function #17 -
Clear Alarms

Function #17 - Clear Alarms is available only on systems with PTI door alarms. Whenever a unit enters the alarm condition, the alarm is logged on the printer and the siren relay is triggered. Further alarms for the unit are then disabled until this function is executed to clear the alarm condition. This prevents a single unit from setting off the alarm multiple times without intervention by the manager to investigate the alarm. Function #17 clears all units on the property from the alarm condition, so if multiple units have alarmed, it is only necessary to execute Function #17 one time. **Note that if you forget to execute Function #17 after an alarm, the units that alarmed will be left in the off condition and will not print door activity until Function #17 is executed.**

After selecting Function #17, the display will indicate "**Clearing Alarms...**" for several seconds while the PTI Falcon searches for all units in the alarm condition and clears them. The display will then return to the date and time.

Clearing
Alarms...

Function #18 -
Read All Doors?

Function #18 - Read Doors is available only on systems with PTI individual door alarms. During normal operation of the PTI Falcon door alarm system, the base unit does not constantly read the condition of all doors. Rather the door alarm system informs the base unit whenever a door changes condition (opens or closes). When a system is first started, the PTI Falcon base unit assumes that all doors are initially closed. If you wish to force the base unit to read all doors so that it will be aware of doors that start in the open condition, Function #18 can be used. It is recommended that you use Function #18 any time that you have restarted the PTI Falcon base unit from a power down or memory load to guarantee that the base unit contains accurate information concerning door condition.

Function #18 must be executed on one door alarm controller at a time. You will be asked to enter the remote number for the door alarm multiplexer that you wish to read. Use Function #18 on door alarm remotes **only**, not on remote keypads or other remote devices. After executing Function #18, the display will return to the date and time. Although there is no visual indication, the PTI Falcon will spend the next several seconds talking extensively with the remote you selected in order to read all doors on that remote.

Read Remote
Number? **3**

In order to completely read all doors on the property, execute Function #18 once for each remote door alarm controller. Your installer should tell you which remote numbers are door alarm controllers on your property. Allow approximately ten seconds after executing Function #18 on one remote before executing Function #18 on another remote.

Function #19 -
Unk Door Print?

Function #19 - Unknown Door Print is available only on systems that use PTI door alarms. When a door on an alarm control box opens or closes on a unit which you have not programmed into the PTI Falcon, it is called an **Unknown Door**. If unknown door printing has not been turned off, the PTI Falcon will log the unknown door event on the printer as part of the access log. Since the unit has not been programmed into the PTI Falcon, it cannot print the unit number that is assigned to the door; it instead prints the remote number and physical wire terminal number for the door. If you have not programmed vacant units into the PTI Falcon and do not wish to see the "Unknown Door" printout every time a vacant unit door is opened or closed, you may turn off the "Unknown Door" printing with Function #19.

Upon selecting Function #19, the display will appear as illustrated. Press "#" if you want unknown doors to be printed, or press "*" if you do not want unknown doors printed.

Print Unk Doors
(Y/N)?

Despite the fact that you may later turn off unknown door printing, it is a very important tool for a newly installed system. If the installer is not certain of the exact order in which the door alarms are wired, he may walk the property and open the doors in order by unit number before the PTI Falcon is programmed. When complete, the printer will contain a list of "unknown doors" that gives the installer the exact wiring order for all doors on the property.

Function #20 -
Set Relay Times?

Function #20 - Set Relay Times is available only on systems with PTI door alarms. It allows you to set the length of the relay closure time for alarm relays and for entrance and exit keypad relays. The times are set in tenths of a second for the alarm relays and eighths of a second for the keypad relays. In addition, Function #20 allows you to specify the number of remotes that are present on the PTI Falcon system.

After selecting Function #20, the display will ask you for the Business Hours setting for the siren relay (in tenths of a second). In the example shown, 100 is entered to specify 10 seconds. If an alarm occurs during the programmed business hours, the siren will sound for 10 seconds and then automatically shut down.

Bus Hrs = 00600
New Val = **100**

The display will then ask you for the After Hours setting for the siren relay (in tenths of a second). In the example shown, 6000 is entered to specify ten minutes. If an alarm occurs outside of the programmed business hours, the siren will sound for ten minutes and then shut off.

Aft Hrs = 03000
New Val = **6000**

The display will then ask you for the keypad relay time (in eighths of a second). In the example shown, 40 is entered to specify five seconds. When a customer enters a valid code into an entrance or exit keypad, the keypad relay will close for five seconds and then release.

Keypad Time = 16
New Val = **40**

The display will then ask for the number of remotes that exist on the system. This will usually be the number of remote keypads plus the number of door alarm control boxes. Your installer can verify this number for you. **Do not enter less than the installed number or the PTI Falcon will not communicate with some remote devices.** You can enter more than the installed number

of Remotes = 15
New Val = **5**

up to a maximum of fifteen, but the PTI Falcon will then waste time attempting to communicate to nonexistent remotes.

Specifications

Base Unit Specifications

Voltage: 120 VAC, 60 Hz
Battery: 9 VDC

Current: 500 ma
Fuse: 1 amp

Remote Connector:

Pin 1: RS485 Data Positive
Pin 2: Data Ground
Pin 3: RS485 Data Negative
Pin 4: Battery Jumper
Pin 5: Battery Jumper
Pin 6: Alarm Relay Normally Open
Pin 7: Alarm Relay Common
Pin 8: Alarm Relay Normally Closed

Serial Connector:

Pin 1: RS232 Carrier Detect
Pin 2: RS232 Receive Data
Pin 3: RS232 Transmit Data
Pin 4: RS232 Data Terminal Ready
Pin 5: RS232 ground
Pin 6: Not used
Pin 7: RS232 Request to Send
Pin 8: RS232 Clear to Send

Remote Keypad Specifications

Voltage: 12 - 24 V, AC or DC
Relay Contacts: 1 amp, 24V

Current: 300 ma
Power Fuse: 1 amp
Relay Fuse: 1 amp

Term Strip 1:

Pin 1: 12 VAC Power
Pin 2: 12 VAC Power
Pin 3: Case Ground
Pin 4: Aux Input #1
Pin 5: Logic Ground
Pin 6: Aux Input #2

Term Strip 2:

Pin 1: RS485 Data Positive
Pin 2: RS485 Ground
Pin 3: RS485 Data Negative
Pin 4: Relay Normally Open
Pin 5: Relay Common
Pin 6: Relay Normally Closed

Alarm Mux Specifications

Voltage: 12 - 24 V, AC or DC
Battery: 9 VDC

Current: 300 ma
Fuse: 1 amp

Term Strip 1:

Pin 1: 12 VAC Power
Pin 2: 12 VAC Power
Pin 3: Case ground

Term Strip 2:

Pin 1: RS485 Data Positive
Pin 2: RS485 Ground
Pin 3: RS485 Data Negative

WARRANTY

PTI Falcon Access Control System

Preferred Technology Inc. (PTI) warrants equipment manufactured by PTI to the original purchaser against defects in materials and workmanship, under normal use and service, for a period of one year from the date of shipment, provided recommended installation and maintenance procedures are followed, **and provided that the warranty registration card is promptly completed and returned to Preferred Technology Inc.**

In case of failure due to defective material or workmanship during the warranty period, components found to be defective upon examination by PTI in its sole discretion, will be repaired or replaced with new or factory rebuilt components at the option of PTI. Replacement parts are warranted only for the remaining portion of the original warranty period. Equipment requiring warranty work shall be returned freight prepaid to PTI. PTI will pay freight to return the repaired or replaced items covered by this warranty to the customer.

This warranty does not extend to normal maintenance, which the customer is expected to provide. Further, this warranty does not extend to equipment or component systems manufactured by others and sold by PTI. In such cases, the original manufacturer's warranty shall apply.

This warranty is in lieu of and excludes all other warranties, expressed or implied, including but not limited to the implied warranties of merchantability and fitness for a particular purpose. This warranty shall not extend to damage due to improper installation, maintenance, or use, connection to improper power sources, or to damage caused by fire, flood, lightning, power surge, or other acts of nature. In no event shall Preferred Technology Inc. be liable for any incidental or consequential damages due to any defect or failure of the equipment.

**PREFERRED TECHNOLOGY INC.
300 N. Cedar Street Summerville, SC 29483
(800) 331-6224 (803) 875-4994**