

IMPORTANT: Before you install the automatic gate lock be sure your gate is level, moves freely on its hinges, and does not bind or drag against the ground.

GTO **AUTOMATIC** **GATE LOCK**®

Installation Manual



PLEASE NOTE: Because of the various mounting applications, **no mounting hardware is provided** with the GTO Automatic Gate Lock. All necessary mounting hardware can be obtained from your local hardware store; all other hardware is provided.

This manual shows two examples of the most common installations, and should provide insight into most other applications. If you have any questions during installation, please call (800) 543-1236 for technical support.

For more information on GTO's full line of automatic gate openers and access controls visit our website at www.gtoinc.com

Before You Start...

For the GTO Automatic Gate Lock to work properly, the gate must close firmly against a positive stop and engage the lock catch against the lock receiver. Achieving optimal closure may require slight adjustments to the gate opener settings.

Installing the lock with the Gate Opener may require resetting closed limits and changes to the stall force. See **Setting the Gate Closed Position** in your *Gate Opener Installation Manual* for information on these adjustments.

Set the limits so that the arm holds the gate snug against the stop in the closed position. **IMPORTANT: You may need to spray the locking mechanism with silicone spray initially to help the latch move freely.**

If you are installing the lock on a **Push-to-Open** gate (gate opens *out*), the lock must be installed on the *outside* of the gate. Depending upon the installation, the gate post may need to be "pocketed" to accommodate the lock receiver or you may want to purchase the column mount receiver. Contact the GTO Technical Service Department at (850) 575-4144 for assistance if needed.

NOTE: Positive stops are required for dual gate applications.

Be sure you have all the parts:

- A - Lock with 20' of low voltage wire
- B - Lock Receiver
- C - Clevis Pin
- D - Locking Cap
- E - Lock Board Battery Lead Wires
- F - White Wire (motor lead to lock board)
- G - Lock Control Board (Lock PCB)
- H - 2 Double Spade Tongue terminals
- I - 6 nylon cable ties
- J - Wire Connector
- K - Lock Keys (for manual release)
- L - Lock Decal
- M - Optional Column Mount Receiver 433IH (not included)

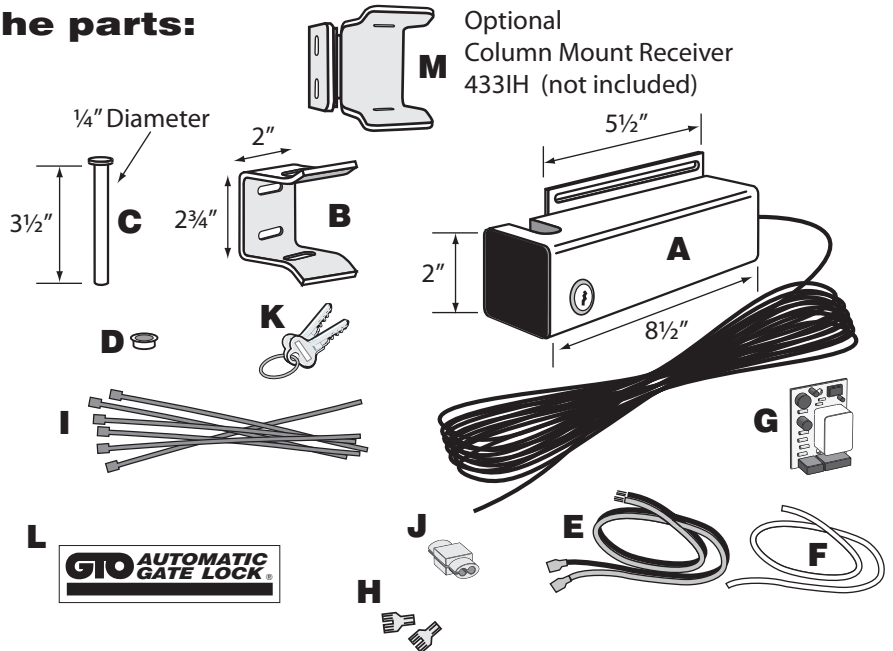

What else do you need?

Mounting hardware is **not included**. Read these instructions completely and review the installation examples to determine the mounting hardware required for your application.

NOTE: The GTO Lock is designed to use mounting hardware **up to 5/16"** in diameter. For a more secure installation, use lock washers and lock nuts on all mounting hardware.

For most **IRON or ALUMINUM TUBE** gates you will need:
Carriage bolts, washers, and nuts for the lock and receiver. (*see Illustration B, page 3*)

For most **CHAIN LINK** gates you will need:
U-Bolts, saddles or carriage bolts, washers and nuts for the lock.
Bolts, washers, and nuts for the receiver. (*see Illustration C, page 3*)

The installation has two parts:

- (1) **Mounting The Lock and Lock Receiver**
- (2) **Connecting the Control Boards**

Once you have the necessary mounting hardware, you can begin the installation.

Installing The Gate Lock

NOTE: The Automatic Gate Lock can be installed on single and dual gate systems. Use the appropriate instructions for the system you have - SINGLE GATE (below) or DUAL GATES (page 4).

Single Gate Installation

Turn power switch **OFF** on the bottom of the control box. Disconnect gate opener by removing hairpin clip and clevis pin from the gate bracket end of the opener. Disconnecting the opener will allow the gate to swing freely during installation of the gate lock.

- Step 1:** With the gate in the closed position, determine the best location for the lock and lock receiver. The lock and receiver must be level and aligned with the opener. Also, the lock should have a solid surface or cross member to provide stability.
- Step 2:** Clamp receiver and lock together (with receiver pin hole and lock slot aligned) against the gate post, mark their positions to drill receiver holes (*see Illustration B and C, page 3*). The receiver must be mounted with carriage bolts, not U-bolts, to allow lock to seat properly. Fasten the receiver to the gate post.
- Step 3:** Hold latch open with key to operate gate and check closed limit and lock alignment. Drop pin in receiver but don't put the cap on. Recheck the lock's position and alignment, then mark its position for drilling holes.
- Step 4:** Drill the holes on gate supports through the slots in the lock bracket. U-bolts and saddles can be used to mount the lock on chain link gate supports. Secure the lock to the gate. Install clevis pin and locking cap by placing clevis pin through slots in lock receiver and hammering the clevis pin into the locking cap (*see Illustration D*), secure the lock bracket and check the alignment again.

Illustration A

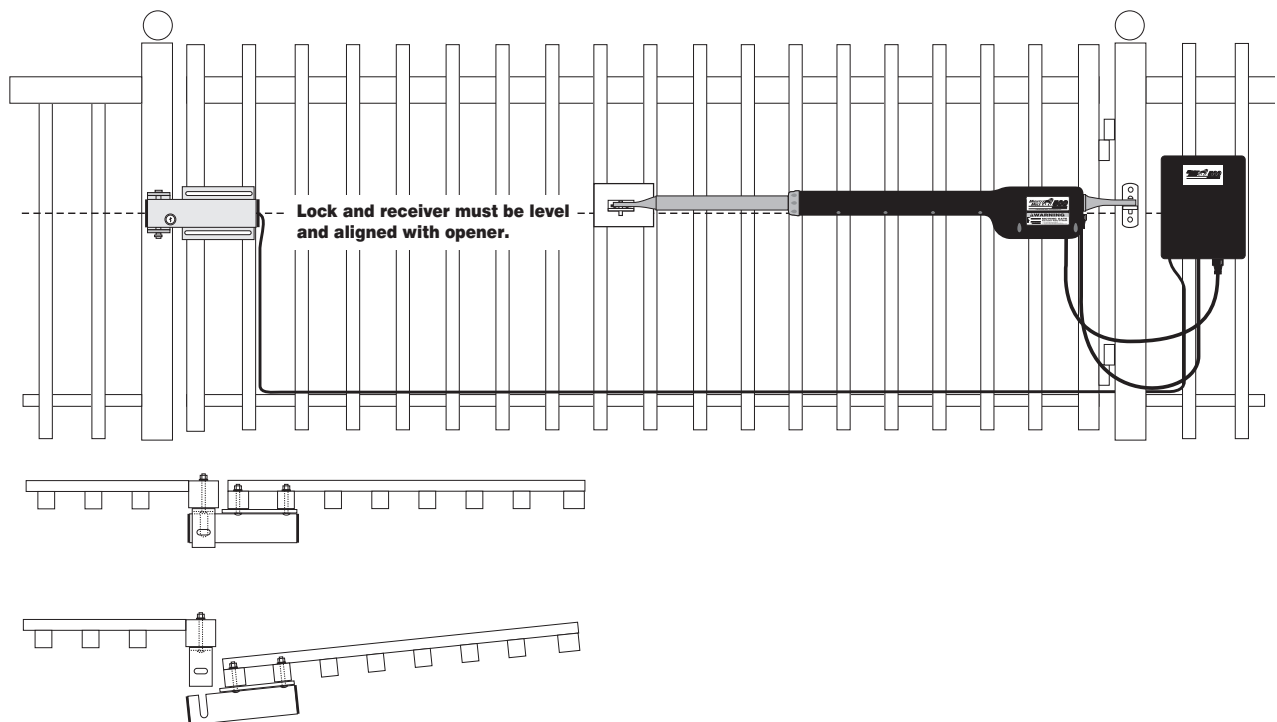

Illustration B

Iron or Aluminum Tube Fence and Gate Installation

Remember to check the alignment and mark positions before drilling holes in fence post and gate.

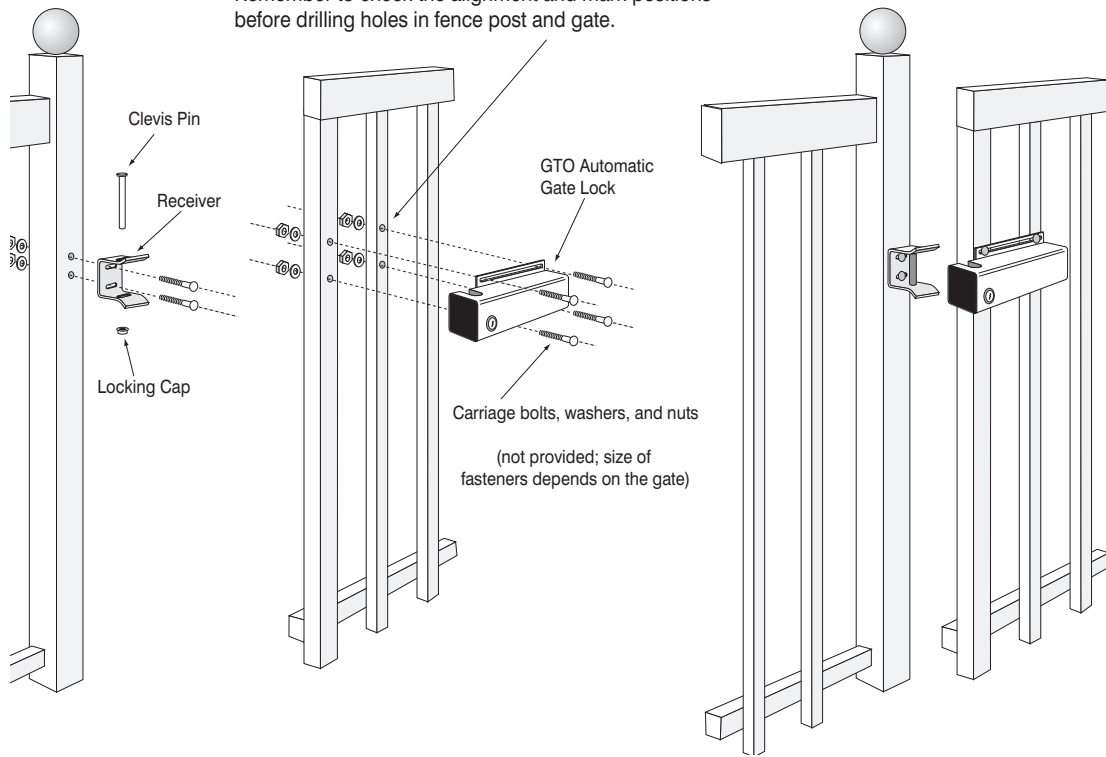

Illustration C

Chain Link Fence and Gate Installation

Remember to check the alignment and mark positions before drilling holes in fence post.

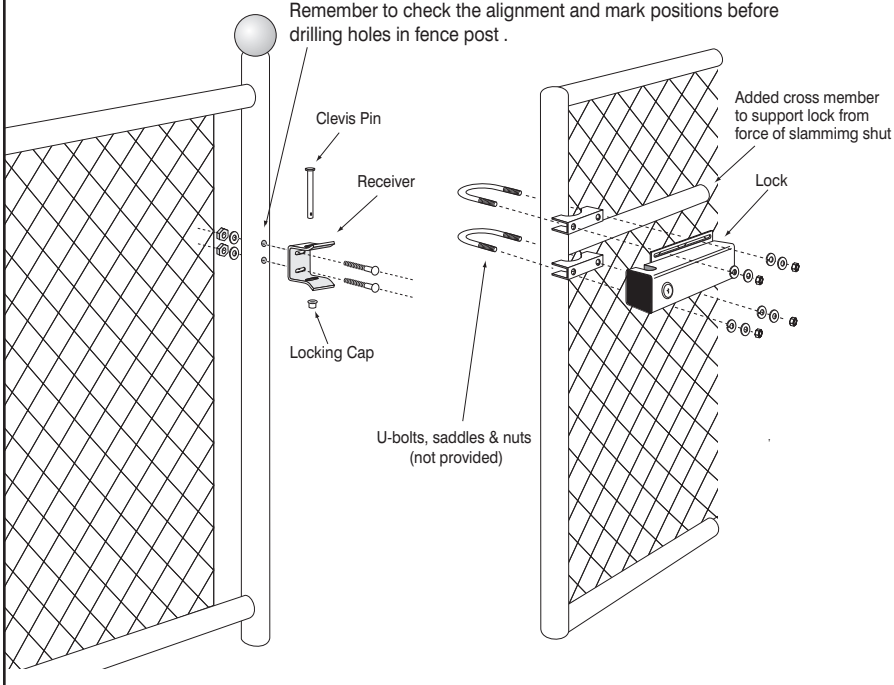
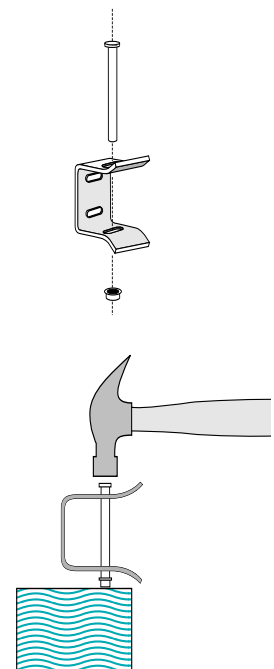

Illustration D

Locking Cap Assembly



Dual Gate Installation

Turn power switch OFF on the bottom of the control box. Disconnect gate openers by removing hairpin clip and clevis pin from the gate bracket end of the openers. Disconnecting the openers will allow the gates to swing freely during installation of the gate lock.

NOTE: In a DUAL GATE INSTALLATION the gate opener on the same side of the driveway as the control box is known as the MASTER GATE OPENER and that gate is referred to as the MASTER GATE. Conversely the gate opener on the other gate is referred to as the SLAVE GATE OPENER and the gate is referred to as the SLAVE GATE.

IMPORTANT: To use the gate lock on a dual gate system, the gate sequencing must be set so the MASTER GATE opens first and closes last, and the gate lock has to be mounted on the MASTER GATE and the lock receiver is mounted on the SLAVE GATE. The slave gate requires a positive stop. If your gates are not sequenced in a manner that works like this, you'll have to change the sequencing DIP switches on your gate opener control board. Follow the instructions in your gate opener installation manual for programming dual gate sequencing.

The diagrams below will show how most dual GTO/PRO® and Mighty Mule® gate sequencing is programmed. If your gate opener control board is different from these shown, please contact GTO Technical Service at 1-800-543-1236 for additional information.

For Mighty Mule® FM702, GTO/PRO® 1000 and GTO/PRO® 2000 Dual Gate Openers

DIP switches

First Operator opens first, Second Operator closes first
SEQ1 = OFF SEQ2 = ON

If SEQ1 is set to OFF, and SEQ2 is set to ON, the FIRST OPERATOR will open first, and the SECOND OPERATOR will close first.

For Mighty Mule® FM502, GTO/PRO® 3000 and GTO/PRO® 4000 Dual Gate Openers

DIP switches

Master opens 2 secs before slave, Slave closes 8 secs before master.
Switch 1 = ON Switch 2 = OFF Switch 3= ON

If Switch 1 is set to ON, Switch 2 is set to OFF and Switch 3 is set to ON, the MASTER OPERATOR will open first, and the SLAVE OPERATOR will close first.

Mighty Mule® 350 Control Board

Master opens 2 secs before slave, Slave closes 8 secs before master.

Switch 2 = OFF Switch 3 = ON Switch 4 = OFF

If Switch 2 is set to off and Switch 3 is set to on the MASTER will open first and the SLAVE operator will close first. Switch 4 must be set to LOCK MODE to avoid damaging circuit board

Gen - 3 (Blue) Control Boards

Master opens 2 secs before slave, Slave closes 8 secs before master.

Switch 4= OFF

If Switch 4 is set to OFF, the MASTER OPERATOR will open first, and the SLAVE OPERATOR will close first.

With the sequencing set correctly follow the steps and diagrams below to mount the lock to the gates.

- Step 1:** With the gate in the closed position, determine the best location for the lock and lock receiver. The lock and receiver must be level and aligned with the opener. Also, the lock should have a solid surface or cross member to provide stability.
- Step 2:** Clamp receiver and lock together (with receiver pin hole and lock slot aligned) to the gates, mark their positions to drill holes (see Illustration E and F, page 6). The receiver must be mounted on the SLAVE GATE with carriage bolts, not U-bolts, to allow lock to seat properly.
- Step 3:** Recheck the lock's position and alignment. Hold latch open with key and operate gate. Drill the holes on gate supports through the slots in the lock bracket. U-bolts and saddles can be used to mount the lock on chain link gate supports. Secure the lock to the MASTER GATE. Install clevis pin and locking cap by placing clevis pin through slots in lock receiver and hammering the clevis pin into the locking cap (see Illustration G), secure the lock bracket and check the alignment again.

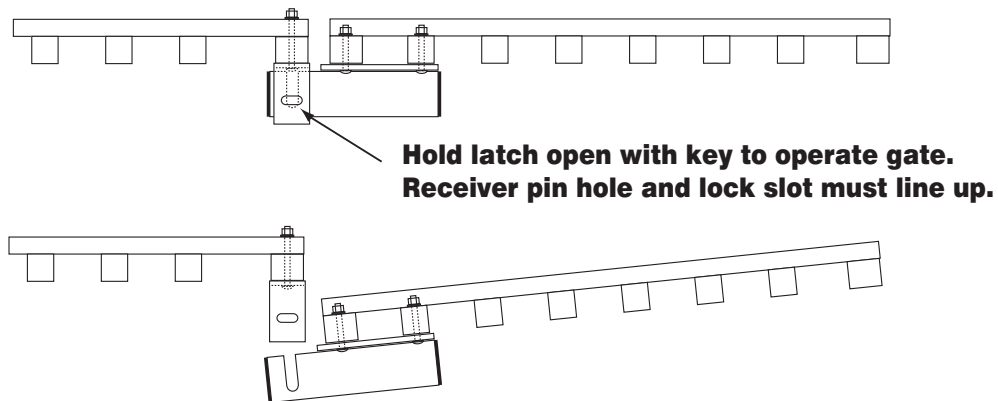
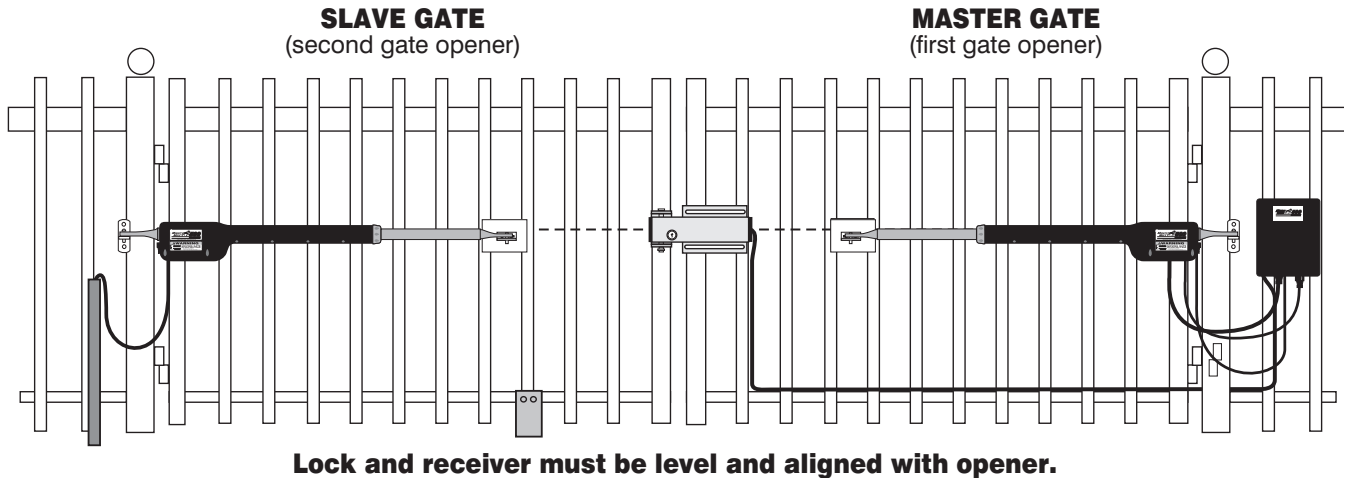

Illustration E

Remember to check the alignment and mark positions before drilling holes in fence post and gate.

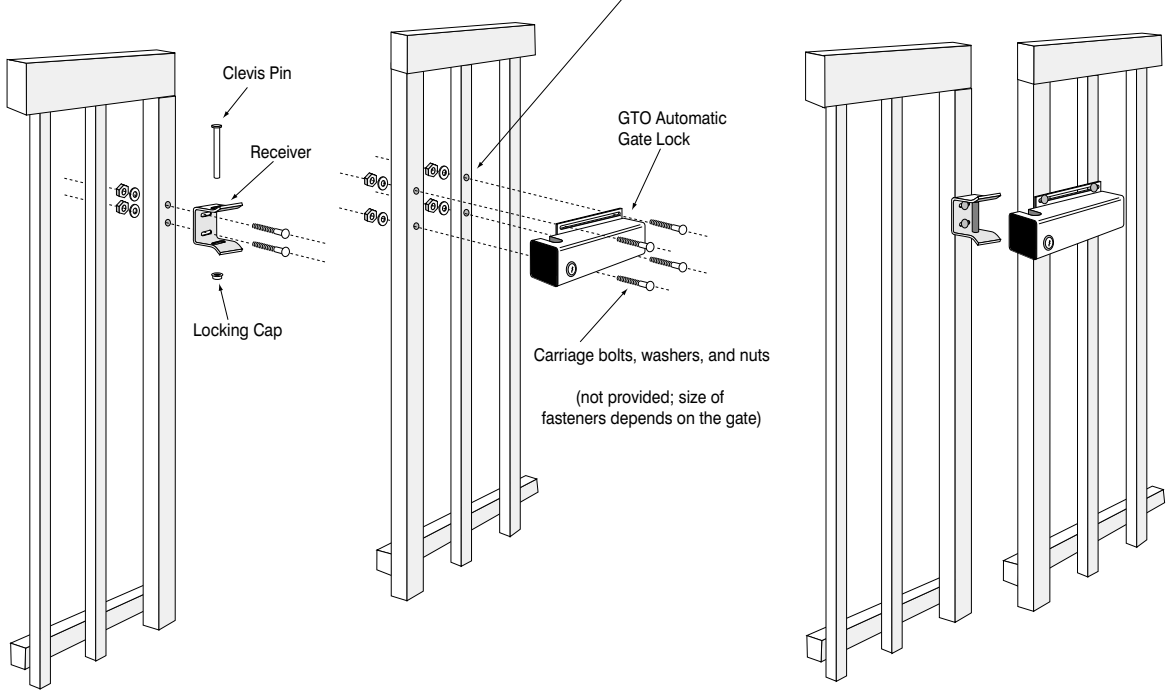

Illustration F

Remember to check the alignment and mark positions before drilling holes in fence post.

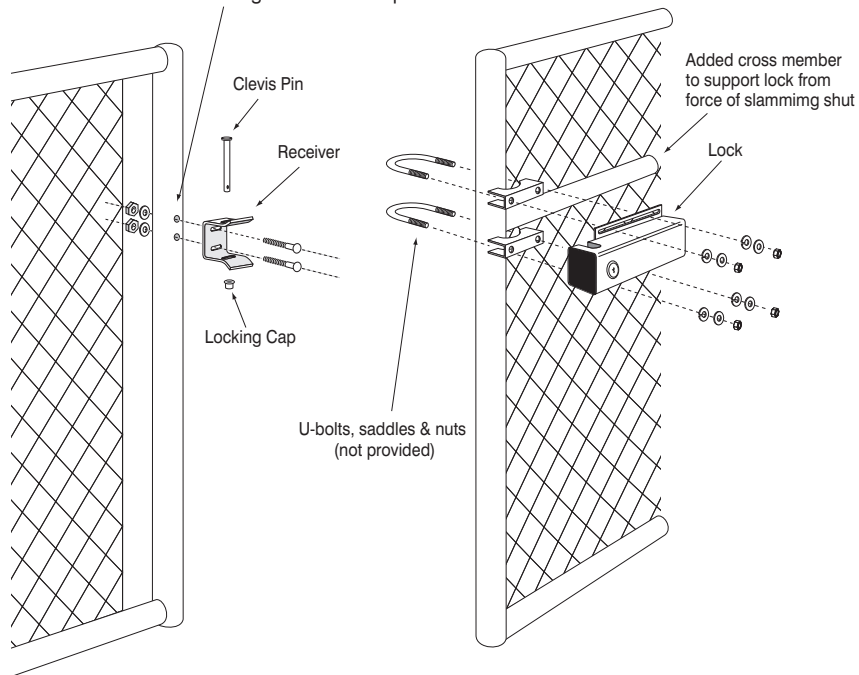
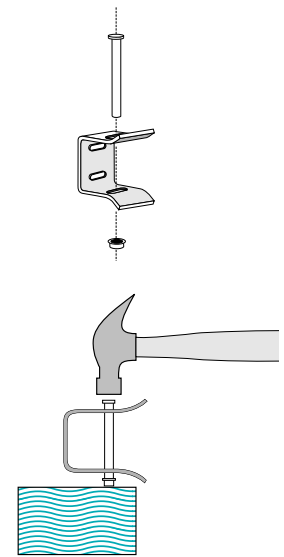

Illustration G

Locking Cap Assembly



Wiring the Lock to Mighty Mule PRO-SW2000XL, PRO-SW3000XL, and PRO-SW4000XL Gate Opener Control Boards

* Place a dab of petroleum jelly on the terminal contacts to prevent corrosion.

Lock Board Wiring Chart

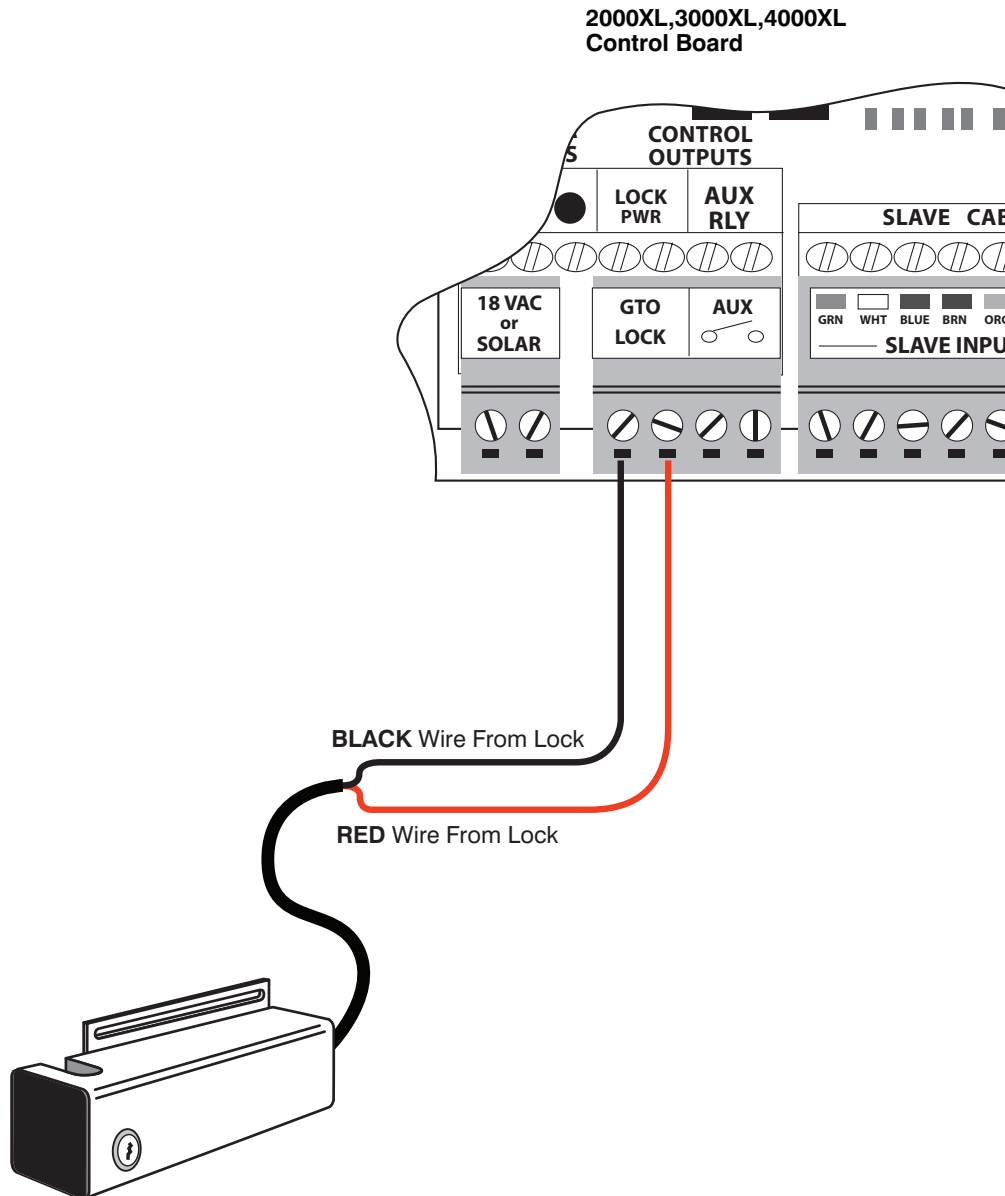

Wiring the Lock to Gate Opener Control Boards

MM500/502, PRO-SW3000, PRO-SW4000

- Step 1.** Turn control box power switch **OFF** and unplug the transformer or disconnect the solar panel. Remove control box cover and disconnect battery lead wires from the battery terminals before wiring the lock board to the opener control board.
- Step 2.** Connect the **WHITE** wire (*included*) to Terminal #1 on the lock board. Connect the **RED** battery lead wire (*included*) to Terminal #5 on the lock board.
- Step 3.** Attach the **RED control board** battery lead wire to one spade tongue on a double spade tongue connector (*included*). Attach the **BLACK control board** battery lead wire to one spade tongue on the other double spade tongue connector (*included*).
- Step 4.** Pull **RED** and **BLACK** wires from gate lock through the strain relief and into the control box. Attach **BLACK** wire to Terminal #3 on lock board. Attach **RED** wire to Terminal #4 on lock board (*see Lock Board Wiring Chart below*).
- Step 5.** Attach **RED lock board** battery lead wire to the double spade tongue terminal with the **RED control board** lead wire. Attach the **BLACK lock board** battery lead wire to the double spade tongue connector with the **BLACK control board** Lead Wire.
- Step 6.** Connect the **WHITE** wire from the lock board directly to the **MASTER OPERATOR** terminal block along with the power cable wire from the opener arm. Connect the **WHITE** wire to the **RED** terminal for a Pull-to-Open installation or connect **WHITE** wire to the **BLACK** terminal for a Push-to-Open installation (*see illustration on page 9*).
- Step 7.** Reconnect opener to gate bracket. Connect the **BLACK** Battery lead wire (*included*) to Terminal #2 on the lock board. (See *Lock Board Wiring Chart below*). Connect **RED** wires (with double spade tongue terminal) to **POSITIVE (+)** battery terminal and the **BLACK** wires (with double spade tongue terminal) to the **NEGATIVE (-)** battery terminal. Plug the transformer in or rewire the solar and turn the control box power switch **ON**. Test opener and lock to make sure it functions properly and make adjustments if necessary.

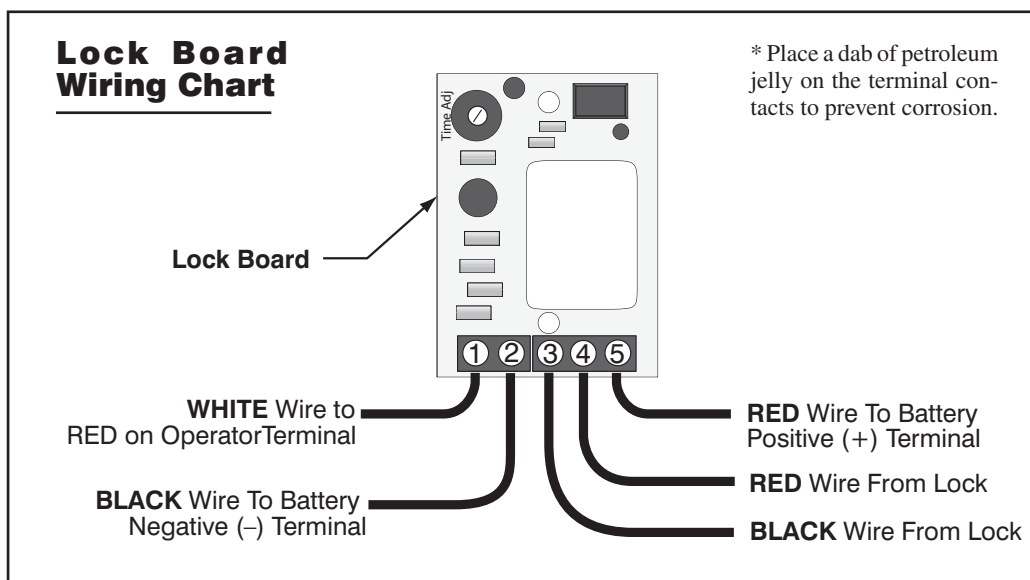

NOTE: It is recommended that the time adjustment knob is turned all the way to the right.

Wiring the Lock to Gate Opener Control Boards

FM700, PRO SW-1000, PRO-SW2000, PRO-SL1000, PRO-SL2000

- Step 1.** Turn control box power switch **OFF** and unplug the transformer or disconnect the solar panel. Remove control box cover and disconnect battery lead wires from the battery terminals before wiring the lock board to the opener control board.
- Step 2.** Connect the **WHITE** wire (*included*) to Terminal #1 on the lock board. Connect the **RED** battery lead wire (*included*) to Terminal #5 on the lock board.
- Step 3.** Attach the **RED control board** battery lead wire to one spade tongue on a double spade tongue connector (*included*). Attach the **BLACK control board** battery lead wire to one spade tongue on the other double spade tongue connector (*included*).
- Step 4.** Pull **RED** and **BLACK** wires from gate lock through the strain relief and into the control box. Attach **BLACK** wire to Terminal #3 on lock board. Attach **RED** wire to Terminal #4 on lock board (*see Lock Board Wiring Chart below*).
- Step 5.** Attach **RED lock board** battery lead wire to the double spade tongue terminal with the **RED control board** lead wire. Attach the **BLACK lock board** battery lead wire to the double spade tongue connector with the **BLACK control board** Lead Wire.
- Step 6.** Connect the **WHITE** wire from the lock board directly to the **FIRST OPERATOR** terminal block along with the power cable wire from the opener arm. Connect the **WHITE** wire to the **BLACK** terminal for a Pull-to-Open installation or connect **WHITE** wire to the **RED** terminal for a Push-to-Open installation (*see illustration on page 11*).
- Step 7.** Reconnect opener to gate bracket. Connect the **BLACK** Battery lead wire (*included*) to Terminal #2 on the lock board. (See *Lock Board Wiring Chart below*). Connect **RED** wires (with double spade tongue terminal) to **POSITIVE (+)** battery terminal and the **BLACK** wires (with double spade tongue terminal) to the **NEGATIVE (-)** battery terminal. Plug the transformer in or rewire the solar and turn the control box power switch **ON**. Test opener and lock to make sure it functions properly and make adjustments if necessary.

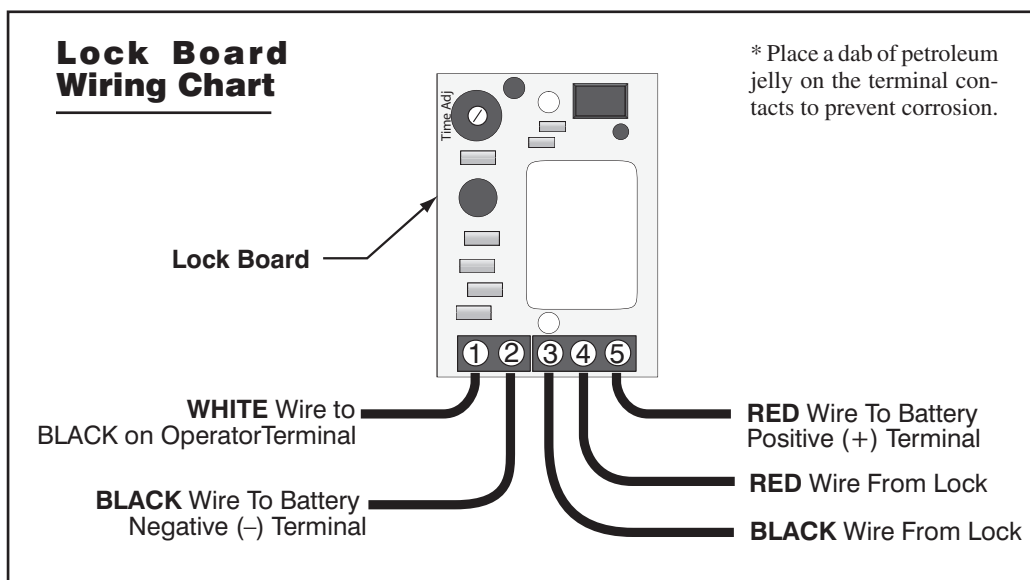

NOTE: It is recommended that the time adjustment knob is turned all the way to the right.

Wiring the Lock to Mighty Mule FM-700/702 and GTO/PRO 1000 and 2000 Gate Opener Control Boards

Lock Board Wiring Chart

* Place a dab of petroleum jelly on the terminal contacts to prevent corrosion.

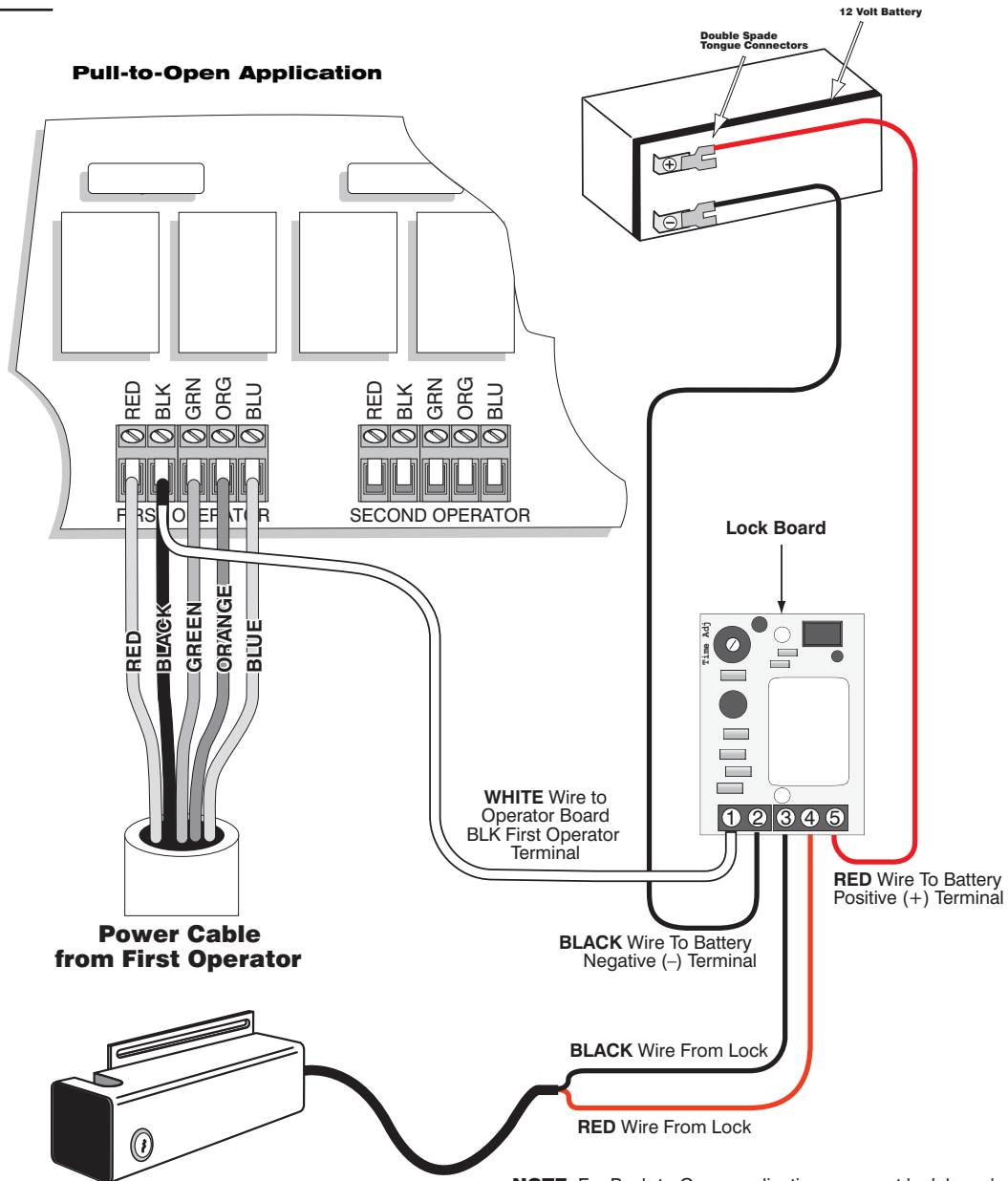

NOTE: For Push-to-Open applications connect lock board white wire to the operator board RED first operator terminal

Troubleshooting

If lock hangs up and does not latch properly try the following steps before contacting Technical Support:

- Reset closed position limit so gate is snug against stop plate
- Lubricate latch with silicone spray to help latch to operate freely
- Check alignment of lock by using the key to hold the latch open while operating the gate opener

If lock still does not operate properly contact the GTO Technical Support Department:

Hours: MON - FRI 8:00AM - 7:00PM (ET)

(800) 543-1236

(850) 575-4144

IMPORTANT: For the optimum service and safety, find the ideal obstruction sensing setting for your gate opener. Depending on the weight of your gate, the ideal setting will be just enough to move your gate without self-obstruction (stopping or reversing due to its own weight), yet sensitive enough to reverse and stop when it meets with an obstruction such as a car. See the *GTO Installation Manual* for information on **obstruction settings**.

NOTE: Be sure your gate moves freely on its hinges without binding or dragging.

Limited One Year Warranty:

GTO, Inc., gate opener accessories are warranted by the manufacturer against defects in workmanship for a period of one (1) year from the date of purchase, provided recommended installation procedures have been followed.

In the case of product failure due to defective material or manufacturer workmanship within the one (1) year warranty period, the accessory will be repaired or replaced (at the manufacturer's option) at no charge to the customer, if returned freight prepaid to GTO, Inc. 3121 Hartsfield Rd., Tallahassee, FL 32303.

IMPORTANT: Call (800) 543-1236 for a Return Goods Authorization (RGA) number before returning accessory to factory. Products received at the factory without an RGA will not be accepted. Replacement or repaired parts are covered by this warranty for the remainder of the one (1) year warranty period or six (6) months, whichever is greater. GTO, Inc. will pay the shipping costs (equivalent to United Parcel Service ground rate) for items repaired under warranty.

The manufacturer will not be responsible for any charges or damages incurred in the removal of the defective parts for repair, or for the reinstallation of those parts after repair. This warranty shall be considered void if damage to the product(s) was due to improper installation or use, connection to an improper power source, or if damage was caused by lightning, wind, fire, flood, insects, or other natural agent.

After the one (1) year warranty period, GTO, Inc. or one of its authorized service centers will make any necessary repairs for a nominal fee. Call GTO at (800) 543-1236 for more information. This warranty gives you specific legal rights, and you may also have other rights which may vary from state to state. This warranty is in lieu of all other warranties, expressed or implied. **NOTE:** Verification of the warranty period requires copies of receipts or other proof of purchase. Please retain those records.