



Invisi-GUARD™TM

Thru-Beam Photo Eye

Monitored / Non-Monitored Externally Powered Emitter



Model # IG-2-K10-E30 or E50 Installation Instructions

The Invisi-Guard-2 thru beam photo optic system sends an invisible beam of light from a transmitting unit to a receiving unit. The light beam is intended to function as a protective line guarding a potentially hazardous zone. When the light beam is interrupted by an obstruction, a signal is sent to the motor controls to stop or reverse motion.

IMPORTANT:

READ AND UNDERSTAND ALL INSTRUCTIONS BEFORE BEGINNING INSTALLATION.

1- Parts List

Check to make sure all parts are included.

- IG-2-E1-E30 or E50 Emitter (1) (Em)
- IG-2-RX Receiver (1) (Rx)
- Mounting Brackets (2)
- Hex Head Mounting Screws (4)
- Flat Washers (4)
- Stop Nuts (4)
- Flexible Conduit (optional)



Assembled Emitter & Mounting Bracket

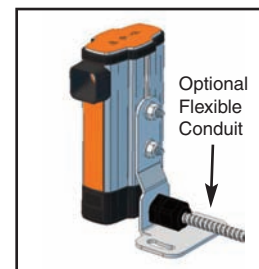

Assembled Receiver & Mounting Bracket

2- Opening Emitter and Receiver Cases

- To open the unit, remove the two (2) phillips screws accessible from the bottom of the lower cap.
- Slide the lower cap from the intermediate piece to expose the PCB.
- Wire the units per Step 5 and 6
- Attach Hex Head mounting bolts to EMITTER and RECEIVER by sliding the head of the bolts into the appropriate channel.
- Re-insert the lower cap into the intermediate piece and re-tighten the screws. (Be sure the notched side of the PC Board aligns with the lens side of the housing.)
- Snap on end cap.

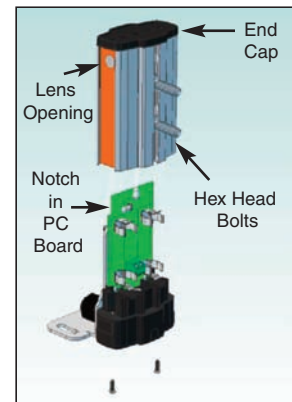

3- Mounting

- Select a stable mounting location with a clear line of site to detect obstructions, where the light beam could not be obstructed by plants, leaves, etc.
- Determine horizontal OR vertical bracket mounting direction. For ease of alignment, both transmitter and receiver should be attached in the same direction.
- Attach Mounting brackets to EMITTER and RECEIVER using the provided hex-head bolts and tighten with nuts.

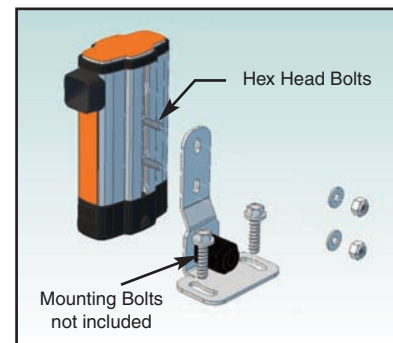

IG2_Inst_20130313

4- Typical Installations

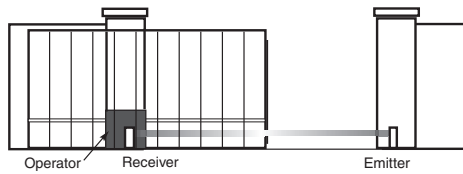

Sliding Gate Installation

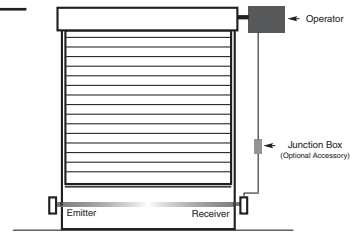

Door Installation

5- Emitter Wiring Connections

- Connect your two power leads to TB1

(TO AVOID THE RISK OF ELECTROCUTION, TURN OFF AND DISCONNECT ELECTRICAL POWER TO THE MOTOR BEFORE WIRING)

6- Receiver Wiring Connections

IG2 Receiver Wiring / Jumper Setting - Not Polarity Sensitive

	TB1	TB2	TB3	J2
Rx Wiring Connections:	12/24VAC/DC	To Operator Monitored Photo Eye Input	NC-COM-NO	
MONITORED	NOT USED	YES	NOT USED	1-2
NON-MONITORED	YES	NOT USED	COM & NO or NC	2-3



Monitored Wiring

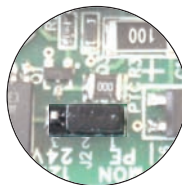

Monitored
J2 Jumper Position

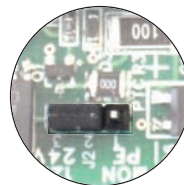

Non-Monitored
J2 Jumper Position

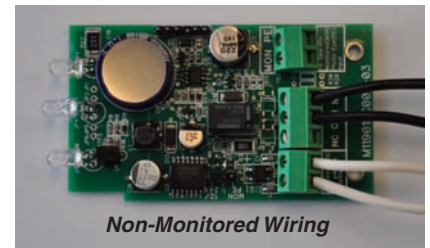

Non-Monitored Wiring

7- Technical Specifications

Detection Technology
Infrared Beam Range
Operating Temperature
Power Supply (Rx) & (Em)

Enclosure

Infrared through-beam
30 feet or 50 feet
-22°F to 144°F (-30° C to 60° C)
8-30 V AC/DC, 50/60Hz
10-24VDC, 100mA
NEMA 4

WARRANTY

We will replace or repair within 2 years of shipment from our factory. Warranty is void where evidence of misuse or abuse is present as determined solely by our authorized factory representative.

8- Trouble Shooting Tips - RECEIVER

LED	Status	Diagnosis	Cause/Solution
GREEN	ON OFF	Power supply is OK No Power	Check for loose or broken wire connections.
RED	ON OFF	Fault Normal Operation	Obstructed Beam or Emitter Batteries Dead. Beam OK

IG2_Inst_20130313



Invisi-GUARD-2™

Thru-Beam Photo Eye

Monitored / Non-Monitored Externally Powered Emitter

8- Trouble Shooting Tips - EMITTER

LED	Status	Diagnosis	Cause/Solution
GREEN	ON	Emitter OK	
	OFF	No Power	Check for Power with DVM

Care and Maintenance:

- Use only a clean lint free cloth to clean transmitting and receiving units.

9- Optional Accessories

• Rubber Boot

The optional Rubber Boot was designed to provide added protection to the IG-2 photo-eyes. The Black TPE (Thermoplastic Elastomer) acts as a durable cover to help protect the photo-eyes from harsh environments.



Assembled Emitter with Boot



Black TPE Boot

How to install the Boot to the Emitter

- Disassemble the Mounting Bracket from the Emitter.
- Slide the Hex Head mounting bolts to the top of the slot.
- Slide the Boot over the top of the Emitter stretching the bottom of the Boot over the screws until they are clear in the slot on the side of the Boot.
- Take care to be sure the Boot is snugly fitted around the Emitter housing.
- Reassemble the Mounting Bracket to the Emitter.



9- Optional Accessories

How to install the Boot to the Receiver

- Disassemble the Mounting Bracket from the Receiver.
- Slide the Hex Head mounting bolts to the top of the slot.
- Remove both screws from the bottom of the Receiver.
- Slide the Bottom Cap & PCB assembly out from the bottom of the Receiver.
- Slide the Hood Sleeve out from the bottom and set it aside. *(It is not needed when using the Boot.)*
- Slide the Boot over the top of the Receiver stretching the bottom of the Boot over the screws until they are clear in the slot on the side of the Boot.
- Take care to be sure the Boot is snugly fitted around the Receiver housing.
- Reassemble the Mounting Bracket to the Receiver.

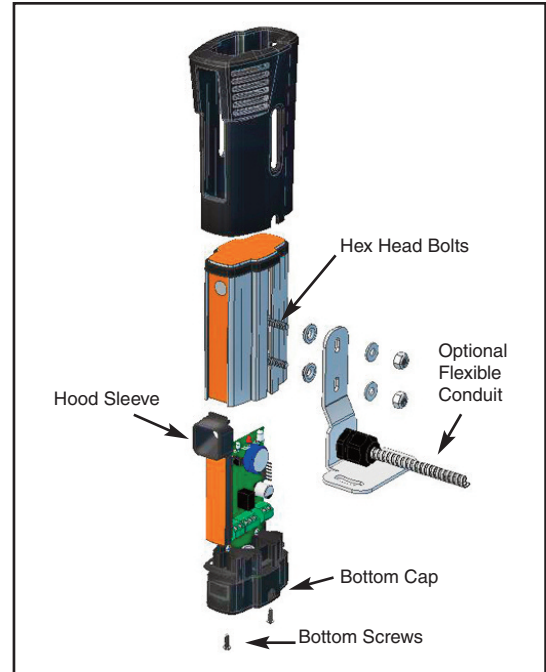

• Extension Pedestal

The Extension Pedestal is made of durable aluminum which matches the exterior housing of both the Transmitter and the Emitter. It provide a means to raise the height of the center of the photo-eyes of the IG-2 from 4 1/2" to 27". It has been designed with a resilient spring loaded mount which will allow for deflection without damage to the unit. The pedestal may be cut in the field as needed for a specific application.

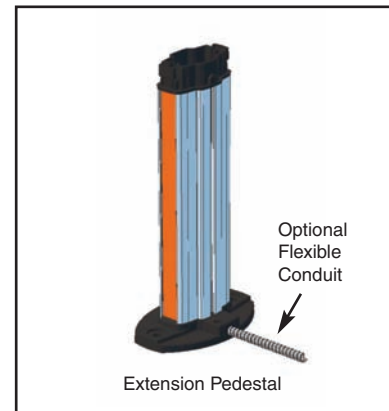

How to install the Extension Pedestal

- Remove the Bottom End Cap from the Emitter/Receiver.
- Feed the wiring through the center of the Pedestal and out the bottom mounting flange to the attached conduit.
- Place the Transmitter/Emitter on top of the Pedestal taking care to align the bottom of the unit with the connecting flange.
- Press down firmly on the unit until the snap feature engages.
- Use the Bottom Mounting Bracket to attach the IG-2 into position.

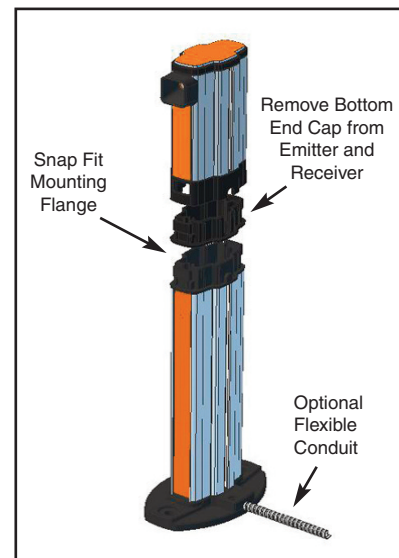

IG2_Inst_20130313