



Instruction Manual

1-801-455-7961

UL 325 Compliant
REV 09-E

IQ GATE SYSTEMS

Warranty Information

This document pertains to all IQ Gate Systems manufactured products. All products that are sold, but not manufactured by IQ Gate Systems are not covered under this warranty. The following warranty covers models including but not limited to:

IQ-50
IQ-500
IQ-500c
IQ-5000
IQ-12B**

IQ Gate Systems reserves the right to alter its warranty coverage and models including coverage duration without prior notification.

Limited Warranty

****IQ Gate Systems model IQ-50 linear gate operator is covered by the following warranty for a period of two years (24 months) from the date of original purchase.**

The built in radio receiver on the IQ terminal board is warranted for 1 year.

IQ Gate Systems new products, not including the IQ-50 linear actuator, are warranted to be free of defects in material or workmanship for a period of three years, (36 months), from the date of purchase. This warranty extends only to wholesale customers who buy direct from IQ Gate Systems or through IQ Gate Systems normal distribution channels. This warranty also only covers and is extended to products that are manufactured by IQ Gate Systems. IQ Gate Systems does not warrant any products in any way to the end user consumer. Consumers must obtain warranty information from the selling dealer and/or installer as to the nature of the dealer's warranty, if any. All contact to IQ Gate Systems from the end user consumer will be referred to the consumer's selling dealer and/or installer. There are no obligations and/or liabilities on the part of IQ Gate Systems for consequential damages arising out of or in connection with use or performance of IQ Gate Systems products or other indirect damages with respect to loss of property, revenue, or profit, or cost of removal, installation, or reinstallation. Any use or change to IQ Gate Systems products not expressly approved by the manufacturer, and performed by an authorized dealer/installer will immediately void the warranty. All implied warranties, including warranties for marketability as well as implied warranties for suitability, are valid only until the warranty expires or is voided, whichever comes first.

This IQ Gate Systems Limited Warranty is in lieu of all other warranties express or implied and all IQ Gate Systems warranties are subject, but not limited, to the following conditions.

NEW PRODUCT POLICY

1. The products must be properly installed as specified; and maintained or used as intended.
2. Cause of product failure is not due to vandalism or malicious mischief, improper installation, abnormal physical or electrical stress, lightning, power surges, misuse, negligence, accidents, or Natural disasters. Normal "wear and tear" from use of equipment is not covered under warranty
3. **Warranty is immediately null and void if the product has been altered, repaired, or modified without express written authorization from IQ Gate Systems Technical Department, with such authorization given only to manufacturer approved dealer/installers.**
4. Under no circumstances will IQ Gate Systems honor warranty on any product found to have been altered, repaired, and/or modified by the end-user consumer.
5. IQ Gate Systems reserves the right to repair the product, or replace a warranted product with a like product of equal value in the event original product cannot be repaired.
6. Distributors and/or Dealer-Installer must first obtain a Return Merchandise Authorization (RMA) number from IQ Gate Systems Technical Department before returning any product to factory for repair, whether under warranty or not. **No returns accepted without RMA.**
7. Return Merchandise Authorization (RMA) numbers will not be issued to the end-user consumers. Consumers must contact their selling dealer-installer for any/all warranty issues.
8. Distributor and/or Dealer-Installer are responsible for all shipping charges, incl. freight and insurance fees, for products shipped to IQ Gate Systems repair center.
9. IQ Gate Systems warranty does not guarantee any product to be free of operation error or service interruption in any way during the course of daily product operation.
10. IQ Gate Systems is not responsible for time, travel, and/or labor costs of any distributor and/or dealer-installer, including but not limited to, any expenses to install, uninstall or reinstall hardware/software/firmware related to warranty issues, product enhancements, or product failures.

IQ GATE SYSTEMS NON-WARRANTY REPAIR LIMITED WARRANTY

NON-WARRANTY REPAIR POLICY

IQ Gate Systems warrants repairs to be free of defects in material or workmanship for a period of three (3) months from the date of repair and invoice. **This warranty extends only to wholesale customers who buy direct from IQ Gate Systems or through IQ Gate Systems normal distribution channels. Consumers must obtain warranty information from the selling dealer and/or installer as to the nature of the dealer's warranty, if any. All contact to IQ Gate Systems from the end user consumer will be referred to the consumer's selling dealer and/or installer.**

This IQ Gate Systems Limited Warranty is in lieu of all other warranties express or implied and all IQ Gate Systems warranties are subject, but not limited, to the following conditions.

1. The products must be properly re-installed as specified; and maintained or used as intended.
2. Cause of repaired product failure is not due to vandalism or malicious mischief, improper installation, abnormal physical or electrical stress, lightning, power surges, misuse, negligence, accidents, or Natural disasters.
3. **Warranty is immediately null and void if the product has been altered, repaired, or modified without express written authorization from IQ Gate Systems Technical Department, with such authorization given only to manufacturer approved dealer/installers.**
4. **Under no circumstances will IQ Gate Systems honor warranty of any product found to have been altered, repaired, and/or modified by the end-user consumer.**
5. IQ Gate Systems reserves the right to replace a previously repaired product with a like product of equal value in the event of repair failure, provided repair failure occurs within the specified warranty period.
6. Distributors and/or Dealer-Installer must first obtain a Return Merchandise Authorization (RMA) number from IQ Gate Systems Technical Department before returning any product to factory for non-warranty repair. **No repair returns accepted without RMA.**
7. Return Merchandise Authorization (RMA) numbers will not be issued to the end-user consumers. Consumers must contact their selling dealer-installer for any/all warranty issues.
8. Distributor and/or Dealer-Installer are responsible for all shipping charges, incl. freight and insurance fees, for products shipped to IQ Gate Systems repair center.
9. **IQ Gate Systems warranty does not guarantee any product, new or repaired, to be free of operation error or service interruption in any way during the course of daily product operation**
10. IQ Gate Systems **is not responsible for time, travel, and/or labor costs of any distributor and/or dealer-installer**, including but not limited to, any expenses to install, uninstall or reinstall hardware/software/firmware related to warranty issues, product enhancements, or product failures.

IMPORTANT REPAIR NOTE: IQ Gate Systems will perform a factory physical evaluation of all products submitted for repair at receipt of item, and reserves the right to decline repairs after said physical evaluation. In the event a returned product is deemed ineligible for repair; the product will be returned to sender via common carrier ground at IQ Gate Systems expense. **NO RETURNS WILL BE REPAIRED, CREDITED, OR RETURNED WITHOUT THE RMA# THAT WAS ISSUED FOR THE MENTIONED PRODUCT FROM IQ GATE SYSTEMS.**

W.Rev C 1010

IQ Gate Systems:

! Warning: Do not install this gate operator if you don't have experience or proper training with gate operators

Important Safety Instructions

WARNING –

TO REDUCE THE RISK OF INJURY OR DEATH - READ AND FOLLOW ALL INSTRUCTIONS.

Never let children operate or play with gate controls. Keep the remote control away from children.

Always keep people and objects away from the gate. **NO ONE SHOULD CROSS THE PATH OF THE MOVING GATE.**

Test the gate operator monthly. The gate **MUST** reverse on contact with a rigid object or stop when an object activates the non-contact sensors. After adjusting the force or the limit of travel, retest the gate operator. Failure to adjust and retest the gate operator properly can increase the risk of injury or death.

Use the emergency release only when the gate is not moving. Make sure that all power to the gate operator is off.

KEEP GATES PROPERLY MAINTAINED. Read the owner's manual. Have a qualified service person make repairs to gate hardware.

The entrance is for vehicles only. Pedestrians must use separate entrance.

SAVE THESE INSTRUCTIONS.

Warning: To reduce the risk of injury or death, please read the following:

1. Read, follow and understand all instructions
2. The automated gate is not for pedestrian use
3. Do not activate your gate operator unless it is in sight and you can determine that it will travel without interfering with any objects or persons. Always keep people and objects away from the gate and its area of travel
4. Keep all access devices such as key switches, push buttons, and telephone entry systems away from the gate. The recommended distance is a minimum of 10 feet.
5. **Make sure that all warning signs have been attached and that the operator has been installed correctly**
6. If edges and photoelectric sensors have been installed, they should be tested for proper operation.
7. Keep gates properly maintained. Grease and lubricate all hinges and brackets to prevent binding and unnecessary friction.
8. Have the operator tested and serviced by a qualified and experienced technician. The gate should respond and reverse to all obstructions both inherently and externally
9. Disconnect the operator only when it is not in motion
10. **DO NOT** turn on the automatic close timer unless the gate is equipped with at least one non-contact external obstruction sensor, e.g., a photo electric beam, a vehicle loop, etc.

RESIDENTIAL VEHICULAR GATE OPERATOR

CLASS I – A vehicular gate operator (or system) intended for use in a home of one-to four single family dwelling, or a garage or parking area associated therewith.

COMMERCIAL/GENERAL ACCESS VEHICULAR GATE OPERATOR

CLASS II – A vehicular gate operator (or system) intended for use in a commercial location or building such as a multi-family housing unit (five or more single family units), hotel, garages, retail store, or other building servicing the general public.

INDUSTRIAL/LIMITED ACCESS VEHICULAR GATE OPERATOR

CLASS III – A vehicular gate operator (or system) intended for use in an industrial location or building such as a factory or loading dock area or other locations not intended to service the general public.

RESTRICTED ACCESS VEHICULAR GATE OPERATOR

CLASS IV – A vehicular gate operator (or system) intended for use in a guarded industrial location or building such as an airport security area or other restricted access locations not servicing the general public, in which unauthorized access is prevented via supervision by security personnel.

1) Install the gate operator only when:

- The operator is appropriate for the construction of the gate (see the ASTM F2200 standard) and the usage UL Class of the gate,
- All openings of a horizontal slide gate are guarded or screened from the bottom of the gate to a minimum of 4 feet (1.22 m) above the ground to prevent a 2-1/4 inch (57.2 mm) diameter sphere from passing through the openings anywhere in the gate, and in that portion of the adjacent fence that the gate covers in the open position,
- Guarding is supplied for exposed rollers.
- All exposed pinch points are eliminated or guarded

2) The operator is intended for installation only on gates used for vehicles. Pedestrians must be supplied with a separate access opening.

3) The gate must be installed in a location so that enough clearance is supplied between the gate and adjacent structures when opening and closing to reduce the risk of entrapment. Sliding gates shall not open “into” public access areas.

4) The gate must be properly installed and work freely in both directions prior to the installation of the gate operator. Do not increase the operator amperage levels beyond the required operable amounts to compensate for a damaged gate.

5) For gate operators utilizing Type D protection:

- The gate operator controls must be placed so that the user has full view of the gate area when the gate is moving,
- The placard be placed adjacent to the controls,
- An automatic closing device (such as a timer, loop sensor, or similar device) shall not be employed
- No other activation device shall be connected.

6) Controls must be far enough from the gate so that the user is prevented from coming in contact with the gate while operating the controls. Controls intended to be used to reset an operator after 2 sequential activations of the entrapment protection device or devices must be located in the line-of-sight of the gate. Outdoor or easily accessible controls shall have a security feature to prevent unauthorized use.

7) All warning signs and placards must be installed where visible in the area of the gate. A minimum of two placards shall be installed. A placard is to be installed in the area of each side of the gate and be visible to persons located on the side of the gate on which the placard is installed.

8) For gate operators utilizing a non-contact sensor such as a photo beam:

- See instructions on the placement of non-contact sensors for each type of application,
- Care shall be exercised to reduce the risk of nuisance tripping, such as when a vehicle, trips the sensor while the gate is still moving
- One or more non-contact sensors shall be located where the risk of entrapment or obstruction exists, such as the perimeter reachable by a moving gate or barrier.

9) For a gate operator utilizing a contact sensor such as an edge sensor:

- One or more contact sensors shall be located where the risk of entrapment or obstruction exists, such as at the leading edge, trailing edge, and post mounted both inside and outside of a vehicular horizontal slide gate.
- One or more contact sensors shall be located at the bottom edge of a vehicular vertical lift gate.
- One or more contact sensors shall be located at the pinch point of a vehicular vertical pivot gate.
- A hardwired contact sensor shall be located and its wiring arranged so that the communication between the sensor and the gate operator is not subjected to mechanical damage.
- A wireless contact sensor such as one that transmits radio frequency (RF) signals to the gate operator for entrapment protection functions shall be located where the transmission of the signals are not obstructed or impeded by building structures, natural landscaping or similar obstruction. A wireless contact sensor shall function under the intended end-use conditions.

Before installation:

- Read and follow all instructions
- Verify that the IQ Gate Systems operator that is being installed is the correct operator for the gate.
- Make sure that the gate has been properly installed and slides freely and level throughout its travel. Repair or replace any damaged or unsafe hardware. A gate that slides free of friction and binding will greatly increase the life of the gate operator.
- Review the operation of the system and the customers needs to make the installation as easy and efficient as possible.
- This gate operator is intended for vehicular gates only. A separate entrance must be provided for pedestrian use.
- The gate should be equipped with positive stops, as well as a mesh or fabric that prevents a gap larger than 2 inches. Please conform with the UL and ASTM standards on building safe and approved gates

During installation:

- Install the gate operator on the secured side of the property and away from public access.
- Be mindful of moving parts and pinch points. Avoid close proximities.
- Installation of contact and non-contact sensors such as edges and photoelectric sensors is suggested to enhance the prevention of entrapment.
- Determine the best level of open and close force for the installation. An improper level will defeat the inherent current sensing purpose and make the installation unsafe. By utilizing the “**Motor Diagnostic**” feature; proper and accurate levels can be obtained when adjusting the open and close force settings. **Improper testing and setting of the force adjustment can increase the risk of serious injury or death.**
- Mount all access controls away from the gate a recommended minimum distance of 10 feet. The gate must be in full view of controls but out of reach.

After Installation:

- Review ALL safety instructions with the end user. Explain the basic operation and features including safety precautions of the entire gate operator system. Don't forget to include how to disconnect power to the operator and how to operate the gate manually.
- Attach all warning signs and placards as well as your own business contact information to the gates. It is recommended that you take a picture of the gates with the warning signs in place and record the date of the photo. Keep for your records.

Installing the Warning Sign

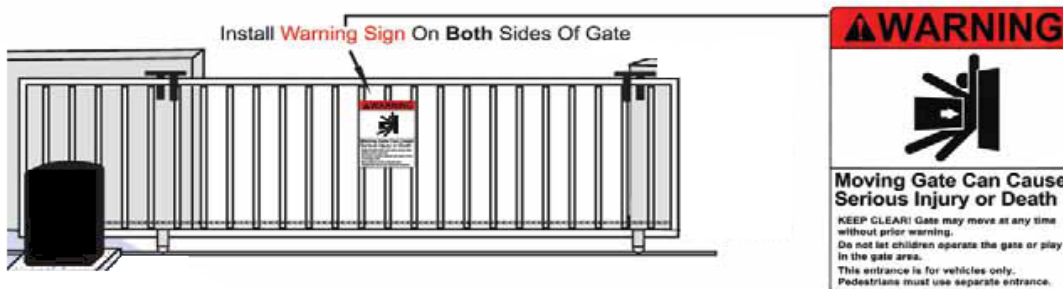

- **SAVE ALL INSTRUCTIONS.** Leave a copy of the manual and your contact information with the end user.
- Survey the desired location for the gate. Make sure that the opening is far enough away from a main road or heavy traffic. Be sure to allow enough distance away from the road so that a vehicle can

- approach the gate without obstructing traffic. Twenty-five feet from the road should be sufficient, but compliance with local codes should be observed.
- Keep power requirements in mind. The IQ is capable of operating with a supply of power from a solar panel that consists of at least 20 watts. AC power is recommended to consist of 110 to 220 volts. AC power is the preferred method of supply.
- Depending on soil conditions, set the concrete pad at least 2 feet in the ground with an abundance of concrete. Check and conform to local codes.
- Install the gate with the incline of the road in mind. For proper operation, the gate must slide back and forth at a level plane.

For Master / Slave Applications:

- The recommended installation of a master/slave or bi-parting slide gate is to pull motor and limit switch wires across the road to the “master” operator. This kind of setup allows for easy programming and servicing of the gate operators. If it is desired to have a Motor Board in each operator, the required number and gauge of wires will remain the same.

The following is the preferred master/slave wiring requirements:

- It is recommended that a total linear footage distance of 90 feet is not exceeded when running the power and communication wires between the master and slave operators. When using larger gauge wires, a junction or terminal block (not included) may be required. If the wire run distance is to exceed 90 feet, please consult IQ Gate Systems for other options.
- Be sure to provide a ¾” conduit between the two gates if they will be set up as bi-parting. A minimum of at least 8 comm. wires and 2 power wires are required for the IQ boards to function with the greatest amount of accuracy. A twisted/shielded 8 conductor wire or equivalent consisting of at least 20 gauge stranded wire and a 14-12 gauge 2 conductor cable will be sufficient. The 14-12 gauge wires are to be provided for the motor power. They will connect the RED and BLACK wires from the motor to the MOTOR A and B terminals on the Motor Board.
- Utilize the 8 conductor cable to terminate the open and close limit switches and the *Encoder* or *Potentiometer* wires from the slave connection terminal block. Connect these wires in the Master operator on the M-2 motor board. The *Encoder / Potentiometer* and the limit switches all utilize a common ground.
- When programming the IQ Control Board for a Master / Slave application, be sure to change the number of operators in the “Motor Drive Menu” to 2 operators. Also, make note of what operator is Motor 1 and what operator is Motor 2 when selecting the on board slide switch on the motor board labeled “M1 – M2”.
- Tighten all necessary bolts and prepare the gate and operator for motion.

Connecting The Power



Be sure that the circuit breaker for the line input power is turned off before connecting the input power to the unit.

- Properly secure and attach the desired form of power in the control box where power termination is labeled.



All units must be properly grounded

The wires are color coded as follows:

- **Black** – 110/220 VAC / Line Input Power
- **White** – Neutral (110 VAC Neutral) or 220 VAC second leg/circuit
- **Green** – Ground Input (from and approved grounding method)
The unit must be grounded

Be sure to use the proper size/gauge of wire in accordance with the distance to the power supply

For power connections: Use Copper Conductors Only

12 AWG	10 AWG	8 AWG	4 AWG
400 ft.	650 ft.	1000 ft.	2000 ft.

- Attach the battery wires to the batteries after the AC power has been terminated and energized.



DO NOT REVERSE BATTERY POLARITY AT THE BATTERY OR THE CIRCUIT BOARD. SEVERE DAMAGE WILL OCCUR

The IQ- is a 24 volt DC gate operator. Utilizing (2) 12 vdc batteries, the batteries must be connected in series, and then the positive (+) power wire (RED) is to be connected to the positive (+) battery terminal

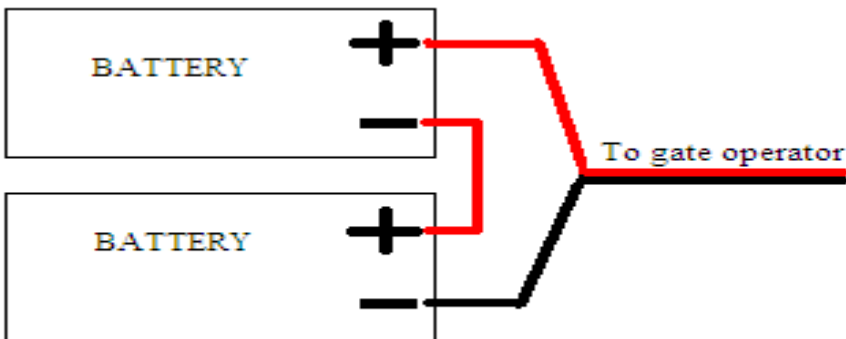

Display / Programming Board

RJ45
Comm.

Reset
Button

“RADIO” or Motion
Activation Button

Programming Knob

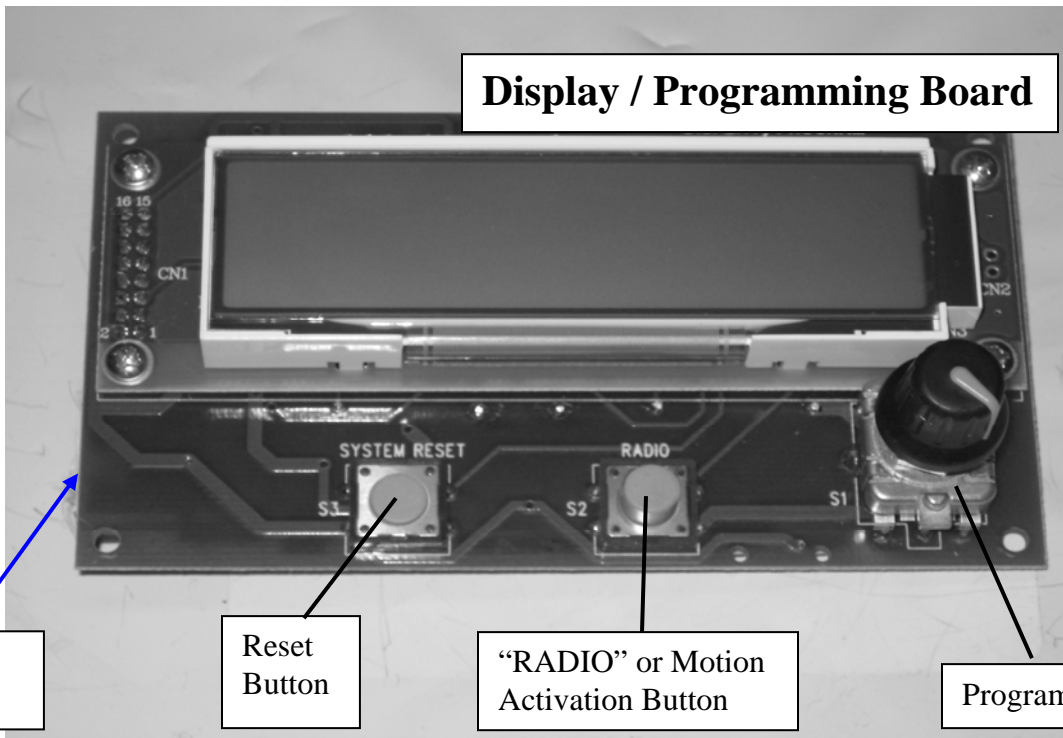

The new revision of the IQ Motor board has two (2) new on board push buttons labeled “OPEN” and “CLOSE”. These buttons will be implemented in a later software revision to be used as a motor limit learning protocol. However, they may be currently used to operate the gate manually for the means of setting the positive limits and overall travel of the gate. To utilize the manual override buttons, perform the following:

1. Unplug the RJ45 Ethernet cable from the DISPLAY/PROGRAMMING BOARD
2. Push and hold the desired manual override button on the MOTOR BOARD

Please note that the manual override button will ignore and run past the limit switches. The gate will not stop unless the button is released or the power is shutoff.

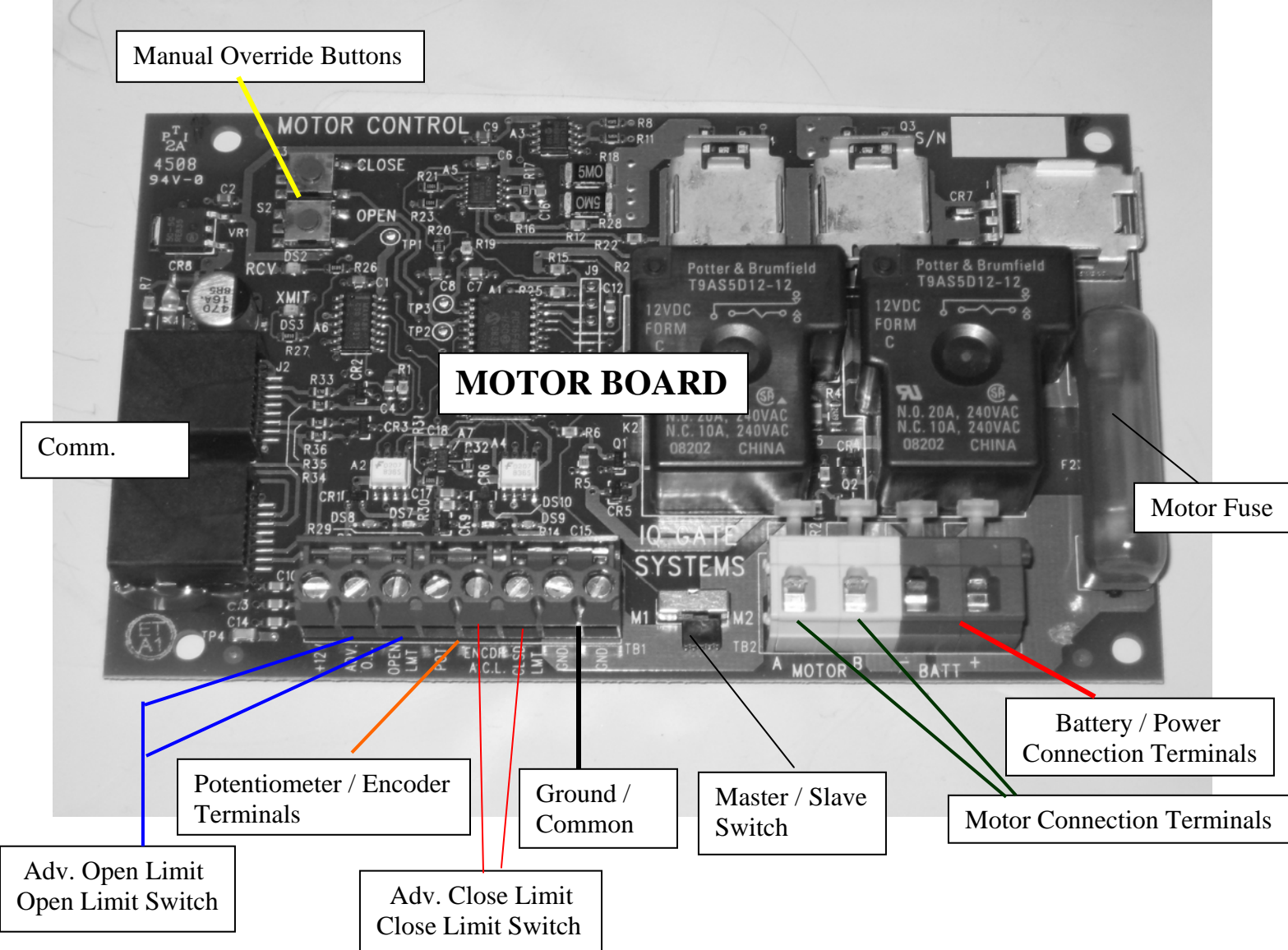

Wiring the IQ Control Board

The IQ Control board utilizes spring loaded terminal connections. To connect or disconnect wires, push the white prong inwards towards the circuit board using a 3/16th inch blade screwdriver; insert or remove the desired wire, and release the pressure on the terminal spade.

The IQ control board has numerous terminals to accommodate your entire accessory wiring needs. The IQ control board uses pull down contacts so that the ground or “GND” terminals should be used as the common contact to complete the circuit for your normally open contacts. The IQ control board also consists of 2 separate power output supplying areas. The Red terminals located at the far most bottom right corner of the Terminal board are labeled {+ 12V}. These 4 terminals can be used for your 12 vdc positive power output terminals and are only designed for 12vdc accessory power. Maximum output is 500ma.

The 5 Orange terminals that are located directly above these are labeled: {28/14 VDC}. These 5 terminals are whatever voltage that the operator is being supplied with, rather it be 12 vdc or 24 vdc.

All of the GND terminals on the board may be used for the “ – “ power terminal or for a common contact.

The 6 terminals at the top right corner of the terminal board are for the termination of ground loops. These terminals correspond with the 3 available plug-in loop detector slots. The loop detector slots are available for use as a EXIT, SAFE and AUX configuration.

- The EXIT detector will provide an open contact to the controller and will display “Exit Loop/Term”.
- The SAFE detector will provide a “safe” or close-reversing contact to the controller and will display “Safe Loop/Term”.
- The AUX detector will provide the output contacts from the detector to the terminals on the board labeled “A – AUX – B”. When a AUX loop is utilized and detecting, the output from the detector will be able to be utilized from the Aux A and B terminals and from here you can jump to whatever contact you would like. For example, if you should require a shadow loop, insert the shadow loop wires into the AUX loop terminals at the top right corner of the board and then use a jumper wire and insert it between the “Aux A” and “Shadow” terminals.

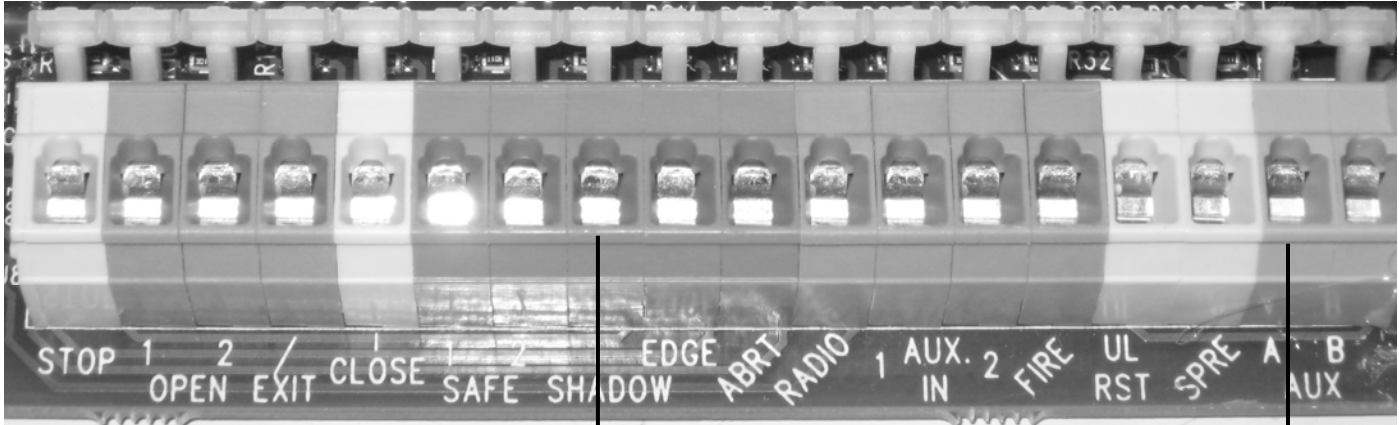

To obtain the function of a Shadow Loop from the AUX Loop Detector, insert a jumper wire from Aux A to Shadow

The IQ Control Board is equipped with (2) 10 amp programmable relays. These relays can be configured to perform a variety of functions. The output terminals for these relays are directly below their corresponding relay.

The output relay functions and input terminal options can be programmed in the Auxiliary Settings Menu.

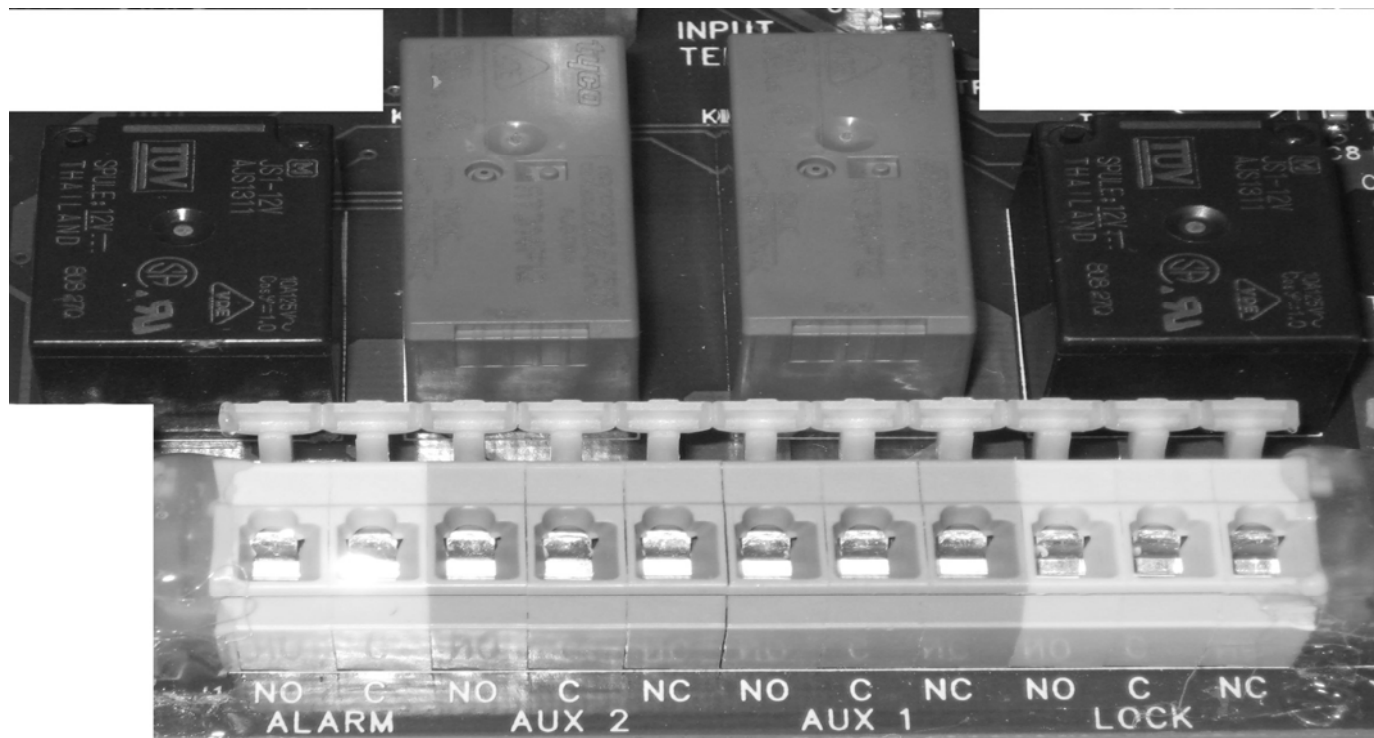

THE FOLLOWING INSTRUCTIONS REFERENCE THE ADDITION AND PROGRAMMING OF THE ON BOARD 433 MHZ DUAL CHANNEL RECEIVER

A coaxial cable antenna kit is required for optimum range and reliability of the on board radio receiver

The on board 433mhz dual channel receiver has a set of four dip switches that can be changed to alter the function of the corresponding channel. Using dip switch 1, channel 1 can be programmed to function as an open only, or a “Radio” command open, stop, close function; or by turning dip switch 2 on (push to the right), it will allow channel 1 to take the action that is programmed in the auxiliary input terminal of the “Auxiliary Settings Menu”.

Channel 2 of the receiver is designed to be used as the reversing input channel. Dip switch 3 can be set to reverse the gate from closing when set as the “SAFE” option, or it can be switched to the “EDGE” option which will reverse the gate in either direction. When dip switch 4 is turned on, channel 2 will take the action of the auxiliary input terminal that is programmed in the “Auxiliary Settings Menu”.

The following is how to program a 433 MHz transmitter into the on board receiver:

1. Push and hold the desired channel “Learn” button (1 or 2) for approximately 2 seconds or until the Green LED DS27 come on and stays on.
2. Next, push and hold the button on the remote transmitter until the Green LED blinks twice (about 4 seconds).

At this point the remote should be programmed. Test the operation of the remote. Press the system reset button if the remote doesn't respond. If the transmitter doesn't operate gate, repeat steps 1 and 2.

To delete the programmed transmitters in channel 1, push and hold the “LEARN” button until the LED goes out (approximately 12 seconds)

Transmitter operational range and functionality can and will differ depending on the site of installation and other nearby obstacles (power lines, electric motors, satellite receivers, fiber optic lines, wireless routers, and other radio frequencies). No guarantee of operational range should be expected or assumed.

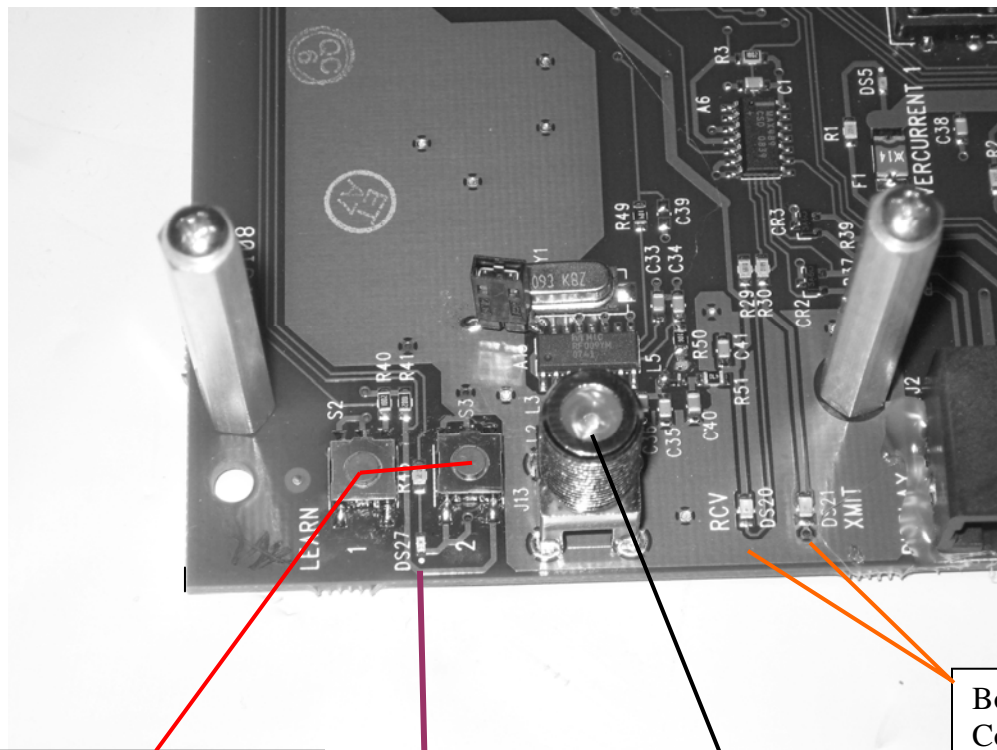

Receiver Programming Buttons

Programming LED

Antenna Connection

Board Communication LED's

Receiver Channel 1 Options

2 Channel Receiver Option Switches

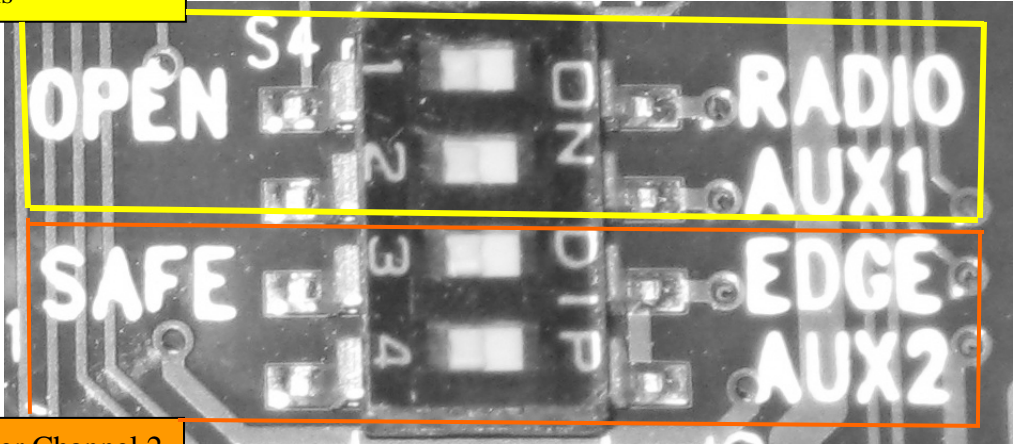

Receiver Channel 2 Options

Programming the IQ Control Board

The following is a list of programming and available features. Please be aware that the IQ control board is one of the most advanced gate operator circuit boards available and take care when programming and choosing desired features. Refer to this manual if a feature that you desire is needed or if any changes are necessary to be made in the menus.



The IQ control board is divided into 7 menus. Using the round rotating programming knob on the display board, you can scroll through the menus and select an option or enter a menu by depressing the programming knob. When changes are being made in any menus the programming “ * “ will be displayed at the top left of the screen. The 7 menus consist of the following:

- Adjust the Clock
- Adjust Time Settings
- Auxiliary Settings
- Maintenance Menu
- Motor Drive Menu
- IQ Gate Learning
- Error and Fault Log

To enter any of the menus, rotate the programming knob one click to the right, or clockwise. The first option that will appear is “Enter Password / None”. This is indicating that the menu is not being password protected. If the password feature was/is being utilized then the appropriate password would need to be entered prior to advancing into the menu past this point. After 1 second, the “Enter Password / None” display will expire and “Adjust the Clock” will be displayed. At this point, you have entered the menu and may scroll clockwise or counter-clockwise to make the adjustments that you desire. To enter a menu, scroll until the one you desired is displayed and push the programming knob to enter. To exit a sub-menu, scroll all the way clockwise until “exit the sub-menu” is displayed and then push the programming knob in. To exit the main menus, just scroll all the way counter-clockwise until the time and date is displayed.

Adjust the Clock:

- Adjust Date / Time
 - Year =
 - Month =
 - Date =
 - Day =
 - Hour =
 - Minute =
- Exit the sub-menu*

Adjust Time Settings

- Maximum Run Timer = adjustable from 10 to 180 seconds, this timer amount represents the maximum number of seconds that the gate operator can run in one direction
- Close Delay Timer = adjustable from OFF to 4:15, this timer represents the amount of time from OFF to seconds to minutes of how long the gate waits to close from the open limit after all open and hold open inputs are removed
- Holiday Next ____ thru ____ (adjustable up to 8 days in advanced) This option is to be used to define what day of the week an upcoming holiday is (if it is desired that the gate not open with the 7-day open timer on that holiday) Just enter the first day of the holiday and the last day of the holiday.
- 7-day open timer = (Completely Off, Off to next {next on program}, On) this is the option in which the 7-day open timer could be activated
- P-1 Open @ 08:00am / Su Mo Tu We Th Fr Sa

(These P-* options are the programmable 7 day auto open timers. You can choose the time and days that the gates automatically open and then close. There are 4 available auto open time slots. To program, adjust the desired time and then display what days you would like the timer to function. If a day is undesired, move the cursor under that day and press the programming knob to erase that day from the program. Then scroll clockwise and set the days and time for the auto close). Here is an example of the 7-day open timer:

P-1 Open: 07:00a Su Mo Tu We Th Fr Sa
--

- 7Day Security Timer = (Completely Off, Off to next {next on program}, On)

(The security timer has 2 available time slots that can be programmed for desired days and times to allow or secure 5 inputs. The inputs that can be secured are: Open, Exit, Radio Terminal, AUX IN 1 and AUX IN 2. To program a secured input, simply program the desired time and the days to secure that input, and also when to release. Then allow the inputs by scrolling to "Secure Inputs, Allow" screen and move the cursor under a desired input. To secure that input, press the programming knob. The inputs that remain displayed will be allowed during the Secured Input timer.

P-1 Secure at 5:30p Su Mo Tu We Th Fr Sa

- Secure Inputs, Allow = Open, Exit, Radio Terminal, Aux In 1 and Aux In 2

Secured inputs Open-Exit-RadioTerm-Aux1- Aux 2
--

Exit the sub-menu

{Some possible and popular uses for the security timer are as follows: a "Free Entrance" loop by day and a "Safety" loop by night; the automatic disabling of the free exit loop after work hours; a controlled output from the auxiliary relays utilizing the Aux In terminals; etc.}

Auxiliary Settings / Enter to View/Adjust

Aux Input Terminal 1
Open

- Aux Input Terminals

(These are available programmable inputs that can be programmed to take on the function that is selected when the AUX terminal is activated)

- Open
 - Safe
 - Shadow
 - Fire
 - Close
 - Photo Eye Close (stops the gate from closing but doesn't reverse the gate)
 - Aux Out 1 (momentary activation of Aux 1 output relay)
 - Aux Out 2 (momentary activation of Aux 2 output relay)
 - Toggle Aux 1 (toggles Aux 1 output relay on/off)
 - Toggle Aux 2 (toggles Aux 2 output relay on/off)
 - 7-day Open Timer Off (turns off the 7-day open timer until the next open schedule)
 - Hold Open (momentary contact will hold open gate and release it)
-
- Aux 1 Output Relay
 - Aux 2 Output Relay
- (These are available options for the Aux 1/2 output relays to perform if selected)
- Pulse on Open Limit (a 2 second relay activation on the open limit)
 - Pulse on Close Limit (a 2 second relay activation on the close limit)
 - Hold on Open Limit (latches the relay on the open limit)
 - Hold on Close Limit (latches the relay on the close limit)
 - Pulse on Motor Open (a 2 second relay activation when gate is opening)
 - Pulse on Motor Close (a 2 second relay activation when gate is closing)
 - Hold on Motor Open (latches the relay when gate is opening)
 - Hold on Motor Close (latches the relay when gate is closing)
 - Hold on UL-325 Alarm (latches the relay upon a UL-325 alarm)
 - Aux Input Received (activates the relay when the Aux input is in use)
 - AC Power Loss (activates the relay upon AC power loss detection which is measured when the gate receives less than 23.5 VDC)
 - Low DC Power (activate the relay upon low DC power detection, a value of equal to or less than 75% of full power supplied)
 - Thermostat Engaged (activates the relay when the thermostat is engaged)
 - Maintenance Request (activates the relay upon a maintenance request)
 - Hold on Motor Run (activates the relay whenever the gate is running)
-
- Recycle Test Mode = OFF, ON (This is for testing purposes. If selected, it will cause the gate to cycle open and close unless stopped with the radio input or turned off in this menu)
 - MRT Exp Limit Option =OFF, ON (This will signal a limit switch in its last direction if the Maximum Run Timer expires)
 - Radio Terminal = Open-Stop-Close, Open Only, Partial Open
 - Partial Open Timed Run = 03 Seconds (this is the programmable amount of time that the gate can run when a partial open signal is given through the Radio Terminal)

- Lock Relay – 2 seconds, 7 seconds, Full Cycle
- Send Transmitter Memory to Display
- Send Transmitter Memory to Terminal Board

Exit the sub-menu

Maintenance Menu

- Main Power/Battery = **24 VDC** or **12 VDC** (should be set at 24VDC for IQ Gate operators)
- Maintenance Request in = Cycles or Days
- Maintenance Request after = __ Cycles or __ Days
- Current _____ Cycles/Days – Enter to reset (pressing the programming knob to enter will erase and reset the current maintenance count)
- Total Operator Cycle = M1 00,000,000 (this is displaying the total accumulated cycles and is non-resettable)
- Low Power Function =
 - Hold Open – the gate will hold open until battery is above 75% full
 - Normal – the gate will continue to function regardless of low power
 - Fire – the gate will only open from a FIRE input
- Alarm Relay = Pulsed or Continuous output
- Motion Warning Type =
 - 3 Sec Pre-Warn – Activates the alarm relay for 3 seconds before motion
 - Motion Warning – Activates the alarm relay 3 seconds before motion as well as during gate motion
 - Off – no audible notification of gate motion
- Reset Password = None or New (press enter to setup a new password)
- Limit Secure = Off or On (this is fail-secure option recommended for use in the IQ-5000 only)
- Input Contacts = Momentary or Constant (affects the OPEN and CLOSE inputs) should be set on Momentary
- Stop Input = Normally Open(default) or Normally Closed
- **De-Icing Mode** = On or Off ([see below](#))
- Activate De-Icing at Temp: 37 F = (user selectable temperature) this temperature setting is used to activate the De-Icing mode if activated. It can also be used to energize the output relays if they have been selected to activate on a temperature selection
- Abrupt Reverse = **Off** or On (this selects rather the gate ramps down or instantly reverses upon a input when closing) Should be set to **OFF**
- Motor Diagnostics View for M1 = Off or On (turns off or on the M1 diagnostics) ([see below](#))
- Motor Diagnostics View for M2 = Off or On
- Temperature Cal Display = (allows the thermostat to be calibrated accurately)

Exit the sub-menu

(The [De-Icing mode](#) is a revolutionary new feature that automatically increases the initial speed as well as the total amperage that is provided to the gate operator when certain conditions, including temperature, are met.)

(The [Motor Diagnostics](#) option is an extraordinary feature that can allow precise adjustment of the motor maximum output force. When M1 or M2 diagnostics are turned on, upon exiting the menus, the display will reflect the motor amperage high and voltage low in real time when the motor is running. At the end of the cycle, the highest amperage and lowest voltage that was last detected will be displayed. By using this feature, proper adjustment to the open and close force settings can be obtained. Be sure to turn the diagnostic features off when not required)

Motor Drive Menu

- Number of Operators in System = 1 or 2
- Operator 1 'IQ' = IQ Gate(default) or Standard (the Standard option does not require the feedback from an encoder from the motor), POTENTIOMETER (for use when implementing a 1K Pot Feedback), or DIGITIZER (when utilizing the IQ DIGITIZER featured in some IQ operators including the IQ-Hydraulic Line)
- M-1 Open Force = user selectable amperage level from 00.1 to 25.0 Default=10.0 amps
- M-1 Close Force = user selectable amperage level from 00.1 to 25.0 Default=10.0 amps
- Force Delay= **0.5 (recommended)** this is the selectable time from .5 seconds up to 2 seconds in which the amperage may be reached or exceeded before the gate reverses due to a motor open or close force alarm
- M-1 Max Speed = user selectable maximum motor speed from 10% to 100%
- M-1 Min Speed = user selectable minimum motor speed from 10% to 90%
- M-1 Open Delay = sets the desired open delay from 0.0 seconds to 5.0 seconds
- M-1 Close Delay = sets the desired close delay from 0.0 seconds to 5.0 seconds
- M-1 Acceleration Step Size = sets the rate of motor acceleration- the higher the rate, the faster the ramp up to the maximum set speed
- M-1 Deceleration Step Size = sets the rate of motor deceleration- the higher the rate, the faster the ramp down to the minimum set speed
- Operator 2 'IQ' = IQ Gate or Standard

All M-2 options are the same as M-1

Exit the sub-menu

IQ Gate Learning – Enter if Applicable

(This menu is only used if “learning” IQ Gate Operators. This is the menu that will allow you to set the desired closed limit as well as the location of the soft stop in a percentage value. To LEARN an IQ Gate style gate operator, please refer to the “Quick Start Guide” section of this manual.)

- Enter for Motor 1 Learning Mode
 - Use 'Radio' to learn Close Count / or (Use Open / Close) Button to set limits
 - I-M-1 Close limit is _ _ _ _ counts
 - I-M-1 Open Slow Down at _ _ % (this is the percent of gate travel that the soft stop would begin)
 - I-M-1 Close Slow Down at _ _ % (this is the percent of gate travel that the soft stop would begin)
- Enter for Motor 2 Learning Mode
 - Use 'Radio' to learn Close Count / or (Use Open / Close) Button to set limits
 - I-M-2 Close limit is _ _ _ _ counts
 - I-M-2 Open Slow Down at _ _ % (this is the percent of gate travel that the soft stop would begin)
 - I-M-2 Close Slow Down at _ _ % (this is the percent of gate travel that the soft stop would begin)
- Encoding Failure = Alarm and Stop or Alarm and Reverse
Upon encountering an Encoder err, the gate can be programmed to Stop and activate the Alarm relay, or Reverse to an open or shut-down position and activate the Alarm relay.

Exit the sub-menu

Error and Fault Log – Press Enter to View

Error and Fault Log Press Enter to view
--

This menu will display the recent faults, errors, or important notifications as well as the time and date that they occurred and what the recorded temperature was at that time. You may scroll left or right and view the events as they occurred with the date and time displayed. To *exit the sub-menu*, just press the programming knob.

Quick Start Guide: Example of an IQ-5000 installation

The following are instructions on how to simply and quickly program an IQ controlled gate operator after it has been mounted to concrete pad and attached to the gate.

Be sure to disconnect any magnetic or other gate locks before learning an operator.

1. With the power and battery disconnected, attach the IQ-5000 wires to the “Motor Control” board according to the direction that the gate opens:
The following example is for Right Hand operation
 - The RED wire inserted in the MOTOR B terminal
 - The BLACK wire inserted in the MOTOR A terminal
 - The WHITE wire tightened into a GND terminal on the motor board
 - The GREEN / BLUE wire tightened into the ENCDR / A.C.L. terminal
 - Open and Closed limit switch wires are terminated accordingly with there commons inserted in the GND terminals of the motor board
2. Reconnect the power and / or batteries and turn on the On/Off switch on the side of the control box
3. Disconnect the RJ45 Ethernet cable from the Display board
4. Push and hold the “OPEN” manual override button on the motor control board and manually adjust the open limit
5. Push and hold the “CLOSE” manual override button on the motor control board and manually adjust the close limit
6. Reconnect the RJ45 Ethernet cable to the Display board
7. Set the appropriate date and time
8. Scroll to the “Motor Drive Menu” and select “Number of Operators” = 1, and then select “IQ Gate” as the Operator “IQ”. Scroll all the way clockwise and “Exit the sub-menu”
9. Scroll to “IQ Gate Learning” and press the programming knob.
10. Scroll to and select “Enter for Motor 1”
11. The display will read “Use ‘Radio’ to learn Close Count”, press the programming knob and the programming * will be displayed at the right. At this point, press the RADIO button on the display board. If the gate is not opened, it will begin to. Once the gate is fully opened, it will stop, a series of relays will click, and then the gate will start to close. The gate speed might slow down at some point during closing. This is normal and will assist in accurate placement of the gate in the closed position. When the gate reaches your desired closed position, press the RADIO button again. At this point the gate will stop and reopen. When the gate is fully opened and the relays quit activating, press the RADIO button once more. When the RADIO button is pressed this final time, the programming * will disappear and the gate will close to your selected position and stop.
12. To adjust the gates closed limit, rotate programming knob clockwise until “I-M-1 Close Limit is ##### “ is displayed. Increase this number to close the gate further or decrease the number to stop the gate sooner.
13. To adjust the soft stop position, rotate the programming knob until “I-M-1 Slow Down at 80%” is displayed. To adjust the gate so that it slows down from full speed at a sooner position, lower the percentage. To slow the gate down later in its full cycle, increase the percentage.
14. When finished, scroll clockwise until “Exit the sub-menu” and push the programming knob to enter.
15. Scroll counter-clockwise to the current date and time to exit the menu
16. Once the gates open and closed limits have been set, it is recommended that you adjust the cam that is closest to the close limit and move that cam until it activates the closed limit. This is how the Limit Secure or “fail secure” feature is obtained.

17. If you desire to change the rate of the soft start or soft stop, you can do so by adjusting the rate of acceleration or deceleration in the “Motor Drive Menu”
18. It is highly recommended that you verify the motors running amperage so that you can properly adjust the maximum amperage force for each motor. To do this, rotate the programming knob from the date and time clockwise until the display reads “Maintenance Menu” and push enter to adjust. Scroll clockwise until the display reads “Motor Diagnostics – View for M1 Off”. Press the programming knob to enter and the programming * will be displayed. Rotate the knob until “ON” is displayed, press the programming knob again so that the * disappears and then rotate the programming knob clockwise until “Exit the sub-menu” and push the knob to exit.
19. From here, rotate the programming knob counter-clockwise until the date and time is displayed. Using the RADIO button or any desired open contact, operate the gate and view the amperage. When the operator is not running, the previous highest amperage and lowest voltage requirements will be displayed. By using this information, you can adjust the motor amperage in the “Motor Drive Menu” accordingly.
20. Return to the “Maintenance Menu” and turn of the “Motor Diagnostics” for each motor when you no longer need them displayed.

At this point, the IQ-5000 has been learned and may be operated. Remember to disconnect all batteries and power via the On/Off switch before and during any accessory wiring. You may also reconnect any magnetic or other gate locks. If the install is going to consist of a “master and slave” configuration, you can learn M-2 at this time. You may also set any desired open and close leaf delays to assist in a master/slave configuration in the “Motor Drive Menu”.

Troubleshooting Guide

www.iggatesystems.com

1-801-455-7961

Because of the LCD display, LED terminal identifiers, and the on-screen messages, troubleshooting the IQ Control Board is very easy if there is ever a problem that is encountered. With the use of the on-board “RCV” and “XMIT” green and orange blinking LED lights, problems can easily be identified. Some of the on-screen messages that might be displayed are as followed:

M-1 Comm Lost / M-2 Comm Lost =

Check the RCV and XMIT lights as well as the M1/M2
Motor selector switch

M-1= Motor 1

M-2= Motor 2

O= Open

C=Close

Comm= Communication

L/T= Loop/Terminal

Err= Error

This list consists of Displayed Actions. The highlighted ones will also be logged in the Fault/Error menu.

Close Timer On	UL-325 Alarm	Stop Detected
Open Detected	UL-325 Reset	System Reset
Exit Loop/Term	Edge Detected	Max Run Expired Max Run time reached
Radio Detected	FIRE Input	Low DC Power Power below 75%
7-day Timer	Maint. Request	AC Power Lost
Shadow Detected	M-1 Close Force Close Force Exceeded	M1De-Icing Mode DeIcing Mode Entered
Safe Loop/Term	M-1 Open Force Open Force Exceeded	Setup Change Menu Item Changed
Abort Open Term	M-2 Open Force Open Force Exceeded	M-1 Comm Lost Motor Comm Lost

Aux Input Term	M-1 ENCODER err	M-2 Comm Lost Motor Comm Lost
Open Limit	M-2 ENCODER err	Exit L/T > 3min Active more then 3
Close Limit	M1C Lim Secure Close Limit Secured	Safe L/T > 3min Active more then 3
Close Detected	M1O Lim Secure Open Limit Secured	Shadow > 3min Active more then 3
M1 Stuck Relay	Secured Input Secured Timer input	Aux Term > 3min Active more then 3
M2 Stuck Relay	M-1 C L DIR ERR Wrong direction limit	M-2 O L DIR ERR Wrong direction limit
M2 Max Timeout	M-1 O L DIR ERR Wrong direction limit	M-2 C L DIR ERR Wrong direction limit
M2De-Icing Mode DeIcing Mode Entered	M2C Lim Secure Close Limit Secured	M1 Fuse Blown
M-2 Close Force Close Force Exceeded	M2O Lim Secure Open Limit Secured	M2 Fuse Blown

LED Indicators

Terminal Board:

- DS 8 – Stop
- DS 7 – Open (GREEN)
- DS 10 – Exit (GREEN)
- DS 9 – Close
- DS 12 – Safe
- DS 11 – Shadow
- DS 14 – Edge
- DS 13 – Abort
- DS 16 – Radio
- DS 15 – Aux Input 1
- DS 18 – Aux Input 2
- DS 17 – Fire
- DS 23 – UL Reset
- DS 22 – Spare
- DS 1 – Alarm Relay (ORANGE)
- DS 2 – Auxiliary Relay 2 (ORANGE)
- DS 3 – Auxiliary Relay 1 (ORANGE)
- DS 4 – Lock Relay (ORANGE)
- DS 19 – Overcurrent 3
- DS 5 – Overcurrent 1
- DS 6 – Overcurrent 2
- DS 20 – Communication Receive (GREEN BLINK)
- DS 21 – Communication Transmit (ORANGE BLINK)
- DS 27 – Receiver Program (GREEN)

Motor Board:

- DS 1 – Communication Lines Overcurrent (RED)
- DS 3 - Communication Transmit (ORANGE BLINK)
- DS 2 – Communication Receive (GREEN BLINK)
- DS 8 – Advanced Open Limit Terminal (RED)
- DS 7 – Open Limit Terminal (GREEN)
- DS 10 – Encoder / Advanced Close Limit Terminal (ORANGE)
- DS 9 – Close Limit Terminal (RED)

Problem	Possible Cause	Solution
Gate Won't Open	<p>The input that is being used to open gate is being secured by the security timer</p> <p>Open limit tripped/active</p> <p>Low Power – set on FIRE Option</p> <p>Stop command active</p> <p>Close command active</p> <p>Abort command active</p> <p>Edge command active</p> <p>Blown Motor Fuse</p> <p>Comm. lost to motor board</p> <p>Over Current on 1,2 or 3</p> <p>Gate is in UL entrapment</p> <p>No Power</p> <p>Encoder Failure</p> <p>AUX IN active</p> <p>Force Delay set to low</p>	<p>Check the Display and all LED's</p> <p>Check if security timer is active and what inputs are being secured.</p> <p>Verify limit position / reset limit</p> <p>Check battery voltage</p> <p>Remove stop signal / input</p> <p>Remove close signal / input</p> <p>Remove abort signal / input</p> <p>Check edge for activation/failure</p> <p>Check both motor board fuses</p> <p>Verify communication via the REC / XMIT LED's</p> <p>Check and remove shorts or over voltages</p> <p>Survey the area surrounding the gate – when clear, activate the UL-Reset button / terminal</p> <p>Check for any indication of power supplied</p> <p>Operate gate and view the “blinking” output from the Motor board terminal DS-10</p> <p>Verify AUX IN setting and remove contact</p> <p>Increase force delay time to at least 0.5 seconds</p>
Gate Won't Close	<p>Low Power</p> <p>7-day timer hold open</p> <p>Close timer not on / active</p> <p>Exit loop detector/terminal active</p> <p>Safe loop detector/terminal active</p> <p>Shadow terminal active</p> <p>Open input active</p> <p>Stop input active</p> <p>Fire input active</p> <p>Encoder Failure</p>	<p>Check the Display and all LED's</p> <p>Check the Battery voltage and low power function setting</p> <p>Check if the 7-day timer is on and if the program time is active</p> <p>Check the close timer setting</p> <p>Check for a vehicle present, reset loop detector or remove input, check the loop integrity</p> <p>Check for a vehicle present, reset loop detector or remove input, check the loop integrity</p> <p>Check for a vehicle present, reset loop detector or remove input, check the loop integrity</p> <p>Remove contact from input</p> <p>Remove contact from input</p> <p>Remove contact from input and press the system reset button</p> <p>Check the selection of the Encoder</p>

Gate Won't Close		Failure, Operate gate and view the "blinking" output from the Motor board terminal DS-10
	Gate is in UL Entrapment	Survey the area surrounding the gate – when clear, activate the UL-Reset button / terminal
	Blown Motor Fuse	Check both motor board fuses
	Comm. lost to motor board	Verify communication via the REC / XMIT LED's
	Over Current on 1,2 or 3	Check and remove shorts or over voltages
	Edge command active	Check edge for activation/failure
AUX IN active (Hold Open)	Verify AUX IN setting and remove contact	
Force Delay set to low	Increase force delay time to at least 0.5 seconds	
Gate reverses when closing		Check the Display and all LED's
	Check all of the above causes	Check all of the above solutions
	Check the display for a M-1 or M-2 Close Force alert	Verify close force setting and adjust if necessary

The IQ Control Board and operators are virtually maintenance free. However, every 6 months to 1 year, a qualified service technician should inspect, test, and adjust the inherent safety sensor as well as the batteries, chains, and grease the bearings. Also, all bolts and nuts should be tightened and checked for wear. All external accessories should also be tested for proper operation and wiring compliance.