

# SELECT GATE 1A

---

## User/Installer Guide

---



---

Select Entry Systems

---



This page intentionally blank.

## TABLE OF CONTENTS

1.0	INTRODUCTION TO SELECT GATE .....	1
1.1	STANDARD FEATURES .....	2
1.2	SPECIAL FEATURES .....	3
1.3	OPTIONS .....	3
1.4	ENVIRONMENTAL CONSIDERATIONS .....	3
1.5	ELECTRICAL .....	3
1.6	TECHNICAL DATA .....	4
2.0	INSTALLATION INSTRUCTIONS .....	5
3.0	WIRING HOOKUP CONNECTIONS .....	6
3.1	INSTALLATION PROCEDURE .....	7
3.1.1	MOUNTING SELECT GATE .....	7
3.1.2	GROUNDING SELECT GATE .....	8
3.1.3	CONNECTING POWER TO SELECT GATE .....	9
3.1.4	TELEPHONE CABLES TO USE TO WIRE SELECT GATE.....	10
3.1.4.1	CONNECTING RJ-31X .....	11
3.1.4.2	CONNECTING TO HOMES WITH ALARM SYSTEM .....	12
3.1.5	CONNECTING DEVICES TO CONTROL RELAY .....	13
3.1.6	REX INPUT .....	14
3.1.7	ADJUSTING SPEAKER VOLUME .....	15
3.1.8	ADJUSTING MICROPHONE SENSITIVITY .....	16
3.1.9	CHANGING SELECT GATE LIGHT BULB .....	17
4.0	INITIALIZATION AND PROGRAMMING .....	18
4.1	CONFIGURING SELECT GATE .....	18
4.2	FACTORY DEFAULTS AND PROGRAMMING FUNCTIONS .....	19
4.2.1	PIN CODES .....	20
4.2.2	PHONE CODES .....	20
4.2.3	RELAY 1 UNLOCK TONE .....	21
4.2.4	RELAY 1 LATCH TONE.....	21
4.2.5	RELAY 1 ONE HOUR TONE .....	21
4.2.6	RELAY 1 OPEN TIME .....	21
4.2.7	STRIKE OUT COUNT .....	22
4.2.8	LOCK OUT TIME .....	22
4.2.9	RELAY 2 UNLOCK TONE .....	22
4.2.10	RELAY 2 LATCH TONE .....	23
4.2.11	RELAY 2 ONE HOUR TONE .....	23
4.2.12	RELAY 2 OPEN TIME .....	23

## TABLE OF CONTENTS

4.2.13	RING TYPE .....	24
4.2.14	RING COUNT .....	24
4.2.15	CALL WAITING TYPE .....	25
4.2.16	RING DETECT .....	25
4.2.17	BACK BEEP .....	25
4.2.18	TALK TIME .....	26
4.2.19	KEYPAD ON .....	26
4.2.20	PROGRAMMING PASSWORD .....	26
4.2.21	CALL FORWARD TONE .....	26
4.4.22	CALL FORWARD TYPE .....	26
4.2.23	CALL FORWARD ON/OFF .....	27
4.2.24	CALL FORWARD NUMBER .....	27
4.2.25	CLEAR ALL PHONES .....	27
4.2.26	CLEAR ALL PINS .....	27
4.2.27	PRESET ALL RELAYS .....	27
4.2.28	CLEAR ALL CALL FORWARD PARAMETERS .....	28
4.2.29	PRESET ALL MEMORY .....	28
4.3	EXITING PROGRAMMING MODE .....	28
5.0	SELECT GATE OPERATION .....	29
5.1	SELECT GATE CALLING HOUSE .....	29
5.2	SELECT GATE CALLING HOUSE WHEN PHONE IN USE .....	30
5.3	SELECT GATE CALLING OUTSIDE PHONE .....	30
5.4	SELECT GATE USING PIN CODES .....	31
5.5	CALLING SELECT GATE FROM HOUSE .....	31
5.6	PROGRAMMING SELECT GATE FROM HOUSE .....	32
5.6.1	PROGRAMMING SELECT GATE FROM OUTSIDE PHONE .....	32
5.6.2	EXITING PROGRAMMING MODE .....	32
APPENDIX A	SETUP INFORMATION .....	33 - 35
APPENDIX B	QUICK PROGRAMMING GUIDE .....	36
APPENDIX C	SELECT GATE CONFIGURATION GUIDE.....	37

## 1.0 INTRODUCTION TO SELECT GATE

The Select Gate is a product that acts as an intercom and access control system. The Select Gate, when started, intercepts a telephone company phone line and initiates a calling/ringing sequence to the telephone set equipment (up to 5 phones of standard ringer equivalence) in the house or residence. It then provides a voice communication channel from the Select Gate to the telephone set.

If the telephone company line is in use at the time of activation, or if the Select Gate is communicating to a telephone set when an externally generated ring signal is detected, an indicating tone will be placed on the telephone set line at the house or residence. The access management functions are controlled via DTMF (Touch-Tone™) signaling.

The Select Gate is activated by pressing the call button or the "#" on the keypad. Select Gate tones will be provided to alert the caller of system operation.

For dialing outside numbers (other than the house or residence) the Select Gate is a microprocessor based device that will allow entering 1 digit. It then automatically dials the phone number that was programmed into memory. The Select Gate provides a relay output for controlling doors, gates, or any device actuated by a contact closure or contact opening. The Select Gate has programmable 1 to 9 minute talk-time limit, with warning tones near the end of talk time.



A Personal Identification Number (PIN) is available. Entering a 4 digit PIN code, while the Select Gate is on hook, will energize the main control relay. (This assumes a valid PIN number has been programmed into the Select Gate).

While the Select Gate is dialing, the speaker is disconnected, keeping the dialed phone number confidential.

Calling the Select Gate from a Touch-Tone™ telephone will allow the user to control the 2 output relays. When the Select Gate is called, the Select Gate will ring, go off hook and send a one second tone. Entering the proper two digit control password will allow access to the output relays and allow timed, latch and one hour relay control functions. If the 4 digit program password is entered, the Select Gate will enter Remote Programming mode.

**1.1 STANDARD FEATURES:**

- Lighted front panel.
- Uses existing phones and phone lines.
- (Local) Call waiting and transfer.
- Latching relays by calling unit from any Touch-Tone™ phone. (Local or remote).
- 1 hour relay open function.
- Call forwarding function.
- Non-volatile EEPROM memory.
- 100 programmable entry codes (PINS), 4 digits.
- Postal lock input available.
- Request to exit input.
- Unlock time is programmable from 1 to 99 seconds.
- Weather resistant housing.
- Programmable without opening cabinet, from keypad or remote telephone.
- Talk time field programmable from 1 - 9 min.
- Tamper input.
- Crystal controlled tone detection for short burst 50 MS tone.
- Unit will mute tones in speaker during dialing.
- Entry code attempts (strike out) programmable from 0 - 9.
- Remote relay activation.

### **1.2 SPECIAL FEATURES**

- Unit will not accept Touch-Tone™ signals through the microphone.
- (4) ring styles, programmable.
- Programmable background "beep" to indicate you are talking to the gate, when Select Gate has called an outside line.
- Keypad "Beep" feedback.
- Can call unit to activate speaker/microphone, local or remote.
- Ability to call off premises phone numbers, up to 10 (16) digit numbers.
- Remote Touch-Tone™ Programming (locally or off premises), password controlled.
- Multiple relay capability.

### **1.3 OPTIONS:**

CCTV camera.

### **1.4 ENVIRONMENTAL CONSIDERATIONS**

**Indoor or Outdoor:** The standard Select Gate housing is suitable for outdoor installations. Optional pedestal mounts for curb (PST236), street (PST242), or slab mounting (PST1) are also available.

**Dimensions:** Select Gate's largest outside dimensions are 9½" W X 7" H X 4½" D.

### **1.5 ELECTRICAL**

**Power:** The Select Gate uses 16 volt ac 50/60 Hz. A 16 vac 20 va transformer is supplied with each purchase in the U.S. only. The installer may choose to provide their own 12 volt @ 2 amp DC supply.

**Ground:** The Select Gate must be connected to a good earth ground with at least # 16 ga. stranded wire. This wire **MUST** be a minimum of 16 ga. connected to a ground rod or cold water pipe. The maximum wire length is 50 feet. Surge damage protection built into Select Gate is diminished if adequate earth ground is not provided.

**Relay capabilities:** 24 volts AC or DC at 2 amp. Form "C" (N/O N/C) contacts are on the control output relay for controlling devices.

**Gate controllers:** Some solid-state gate controllers react to the over-voltage protection devices used on all SES products. This is a gate controller dependent problem. The symptom is an intermittent gate open condition, or gate stuck open condition, sometimes occurring after using the latching function. If this occurs, add an external relay controlled by the Select Gate output relay contacts to your gate system. This will help isolate the contacts going to your solid state gate controller.

**1.6 TECHNICAL DATA**

- **POWER INPUT:** 16 VAC 20 VA UL LISTED TRANSFORMER (PROVIDED WITH UNIT).
- **TELEPHONE LINE:** RJ31X JACK.
- **SHIPPING WEIGHT:** APPROXIMATELY 8 LBS.
- **CONSTRUCTION:** FRONT PANEL: 16 GA. STAINLESS STEEL.  
BACK BOX: PAINTED CHEMICALLY TREATED ALLOY ALUMINUM.
- **OPERATING ENVIRONMENT:** TEMPERATURE: -20E F TO +140E F.  
RELATIVE HUMIDITY: 5% - 95% NON-CONDENSING.
- **RELAY OUTPUT:** 2 RELAYS: FORM C DRY CONTACT 24V @ 2 AMP.
- **MOUNTING:** SURFACE
- **MEMORY TYPE:** NON-VOLATILE.
- **tone DETECTION:** CRYSTAL CONTROLLED, CAN DETECT SHORT BURST 50 MS TONE.



**NOTE THE FOLLOWING BEFORE ATTEMPTING ANY INSTALLATION:**

- A. Never install telephone wiring during a lightning storm.
- B. Never install telephone jacks in wet locations unless the jack is specifically designed for wet locations.
- C. Never touch uninsulated telephone wires or terminals unless the telephone line has been disconnected at the network interface.
- D. Use caution when installing or modifying telephone lines.

Installation of Select Gate requires co-ordination with your telephone company. It is recommended that a Touch-Tone™ line be installed to allow much faster dialing.

The phone company may require the following information:

The ringer equivalence number.

The FCC registration number.

These numbers are on the label on the inside door of the Select Gate.

The desired location of the telephone jack must be given to the phone company at the time the phone line is ordered, if required.

**NOTE: TELEPHONE COMPANY REQUIRES ACCESS TO TELEPHONE LINE ORIGINATION POINT. SES RECOMMENDS THAT RJ31X JACK BE INSTALLED IN HOUSE OR MADE ACCESSIBLE TO TELEPHONE COMPANY PERSONNEL.**

3.0 WIRING HOOKUP CONNECTIONS

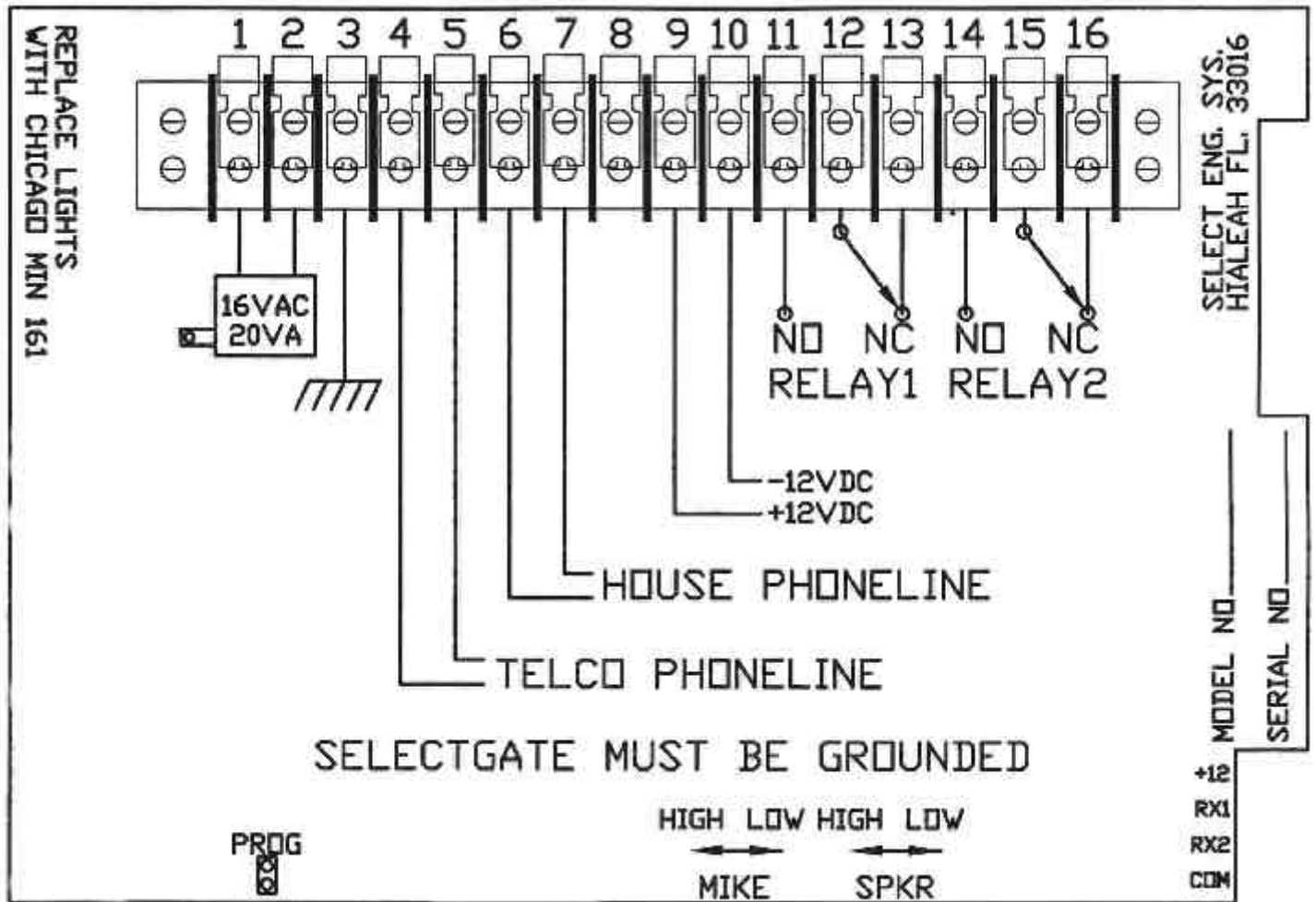

## SELECT GATE SG-1A V1.X

### 3.1 INSTALLATION PROCEDURE

#### 3.1.1 MOUNTING SELECT GATE

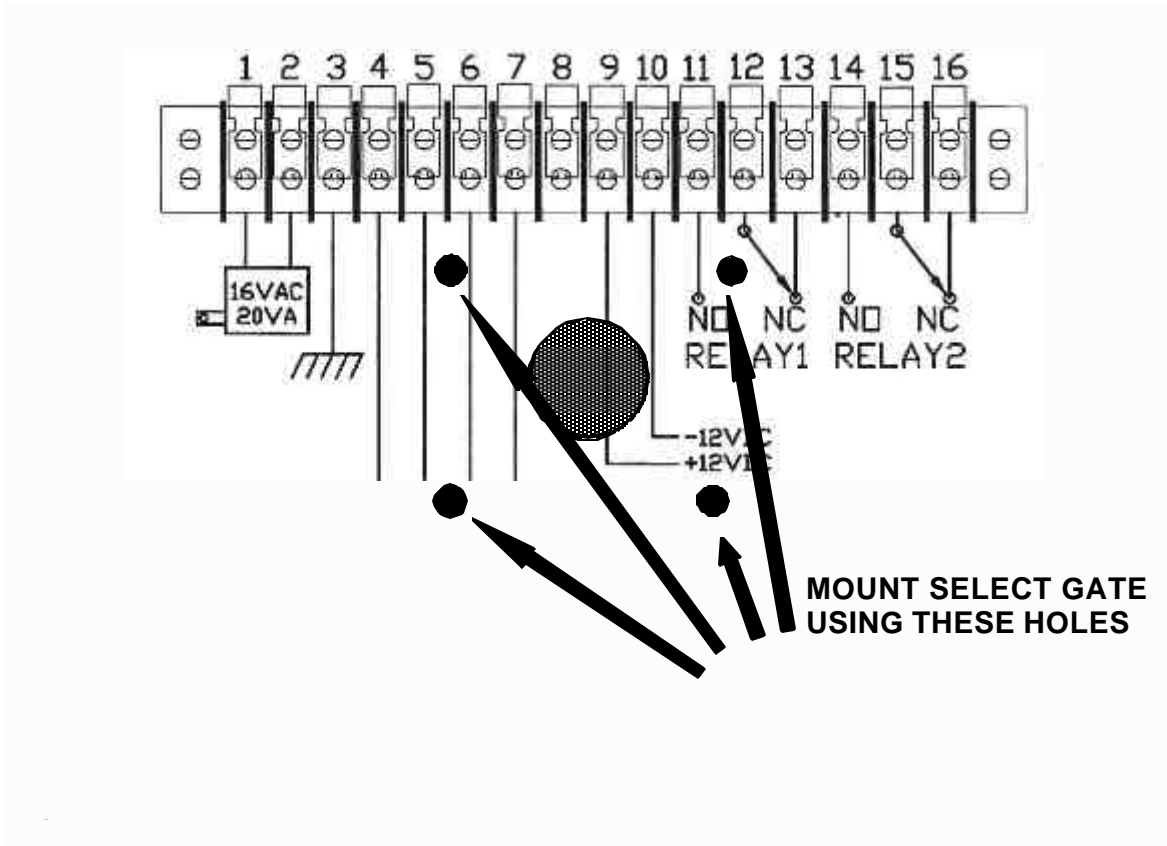

1) The Select Gate should be mounted approximately 48 - 52 inches above finished floor to the center of the Select Gate. For drive up applications, Select Gate should be mounted approximately 48" above finished flooring to the center of Select Gate. Optional hand set units should be mounted 46" above finished floor.

2) To surface mount the Select Gate, mount the back-box using the four ¼" holes provided. Bring all wiring through the 1" diameter hole centered between the mounting holes.

3) For pedestal mounting, pedestals (both curb (PST236) and street (PST242)) are available from SES. Mounting holes on Select Gate back box match these mounts. For other enclosures, holes may be added as required. For pedestals with bottom mount, holes must be chosen with care, so as not to interfere with the electronics, and the face plate mounting.

**NOTE: ALL METAL PARTICLES FROM DRILLING MUST BE REMOVED, BEFORE ELECTRONICS ARE INSTALLED IN SELECT GATE.**

4) All wire openings, or any penetration of the Select Gate enclosure should be sealed with a good grade of RTV silicon sealant.

## 3.1.2 GROUNDING SELECT GATE

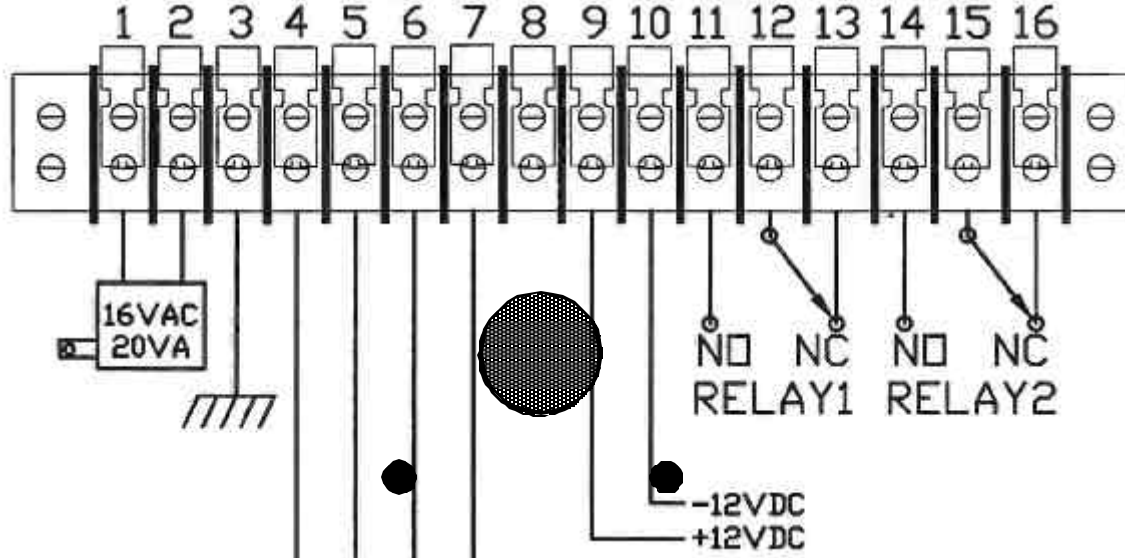

**GROUND WITH  
# 16 GAUGE WIRE  
OR LARGER FOR  
BUILDINGS**

**GROUND WITH  
# 14 GAUGE WIRE  
OR LARGER FOR  
PEDESTALS**

- 1) The Select Gate **MUST BE AT EARTH GROUND POTENTIAL**. Connect a #16 or larger wire to the  $\frac{1}{4}$  - 20 ground lug mounted on the back-box of the Select Gate. This is immediately to the left of the terminal barrier strip. Connect the other end of the ground wire to a cold water pipe or other suitable earth ground. This wire should be less than 50 feet in length.
- 2) If a cold water ground is not available or located within a reasonable distance, a ground rod will have to be installed adjacent to the Select Gate installation. Install the ground rod according to local electrical code requirements. Surge damage protection built into Select Gate is diminished if adequate earth ground is not provided.
- 3) If the Select Gate is mounted on a pedestal, a ground rod **MUST** be installed adjacent to the Select Gate installation. For pedestal installations using a ground rod, # 14 ga. or larger is recommended from the  $\frac{1}{4}$  - 20 ground lug mounted on the back-box of the Select Gate to the ground rod clamp.

## SELECT GATE SG-1A V1.X

### 3.1.3 CONNECTING POWER TO SELECT GATE

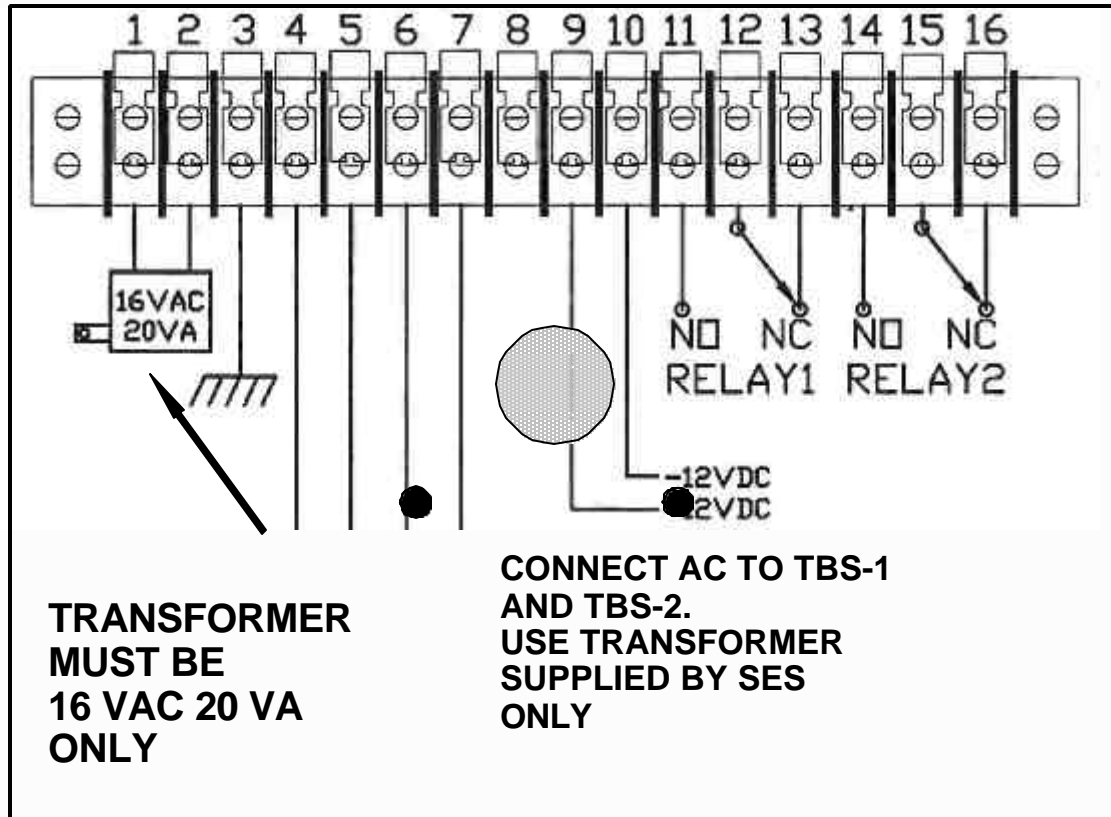

1) Connect the wires for the power connections to TBS-1 and TBS-2, as shown above. Connect the other ends of the wires to the screws on the supplied transformer (16 vac 20 va).

Recommended wire gauge is as shown:

16 ga.	up to 50 feet.
14 ga.	up to 100 feet.

For unusual distances or requirements please consult factory.

2) If a D.C. supply is desired, it must be able to provide 12 volts at no less than 2 amperes, when measured at terminals TBS-9 and TBS-10. This current is necessary to provide sufficient ringing voltage to ring phones in the house or residence.

**NOTE: USE THE TRANSFORMER SUPPLIED BY SES**

**3.1.4 TELEPHONE CABLES TO USE TO WIRE SELECT GATE**

The Select Gate is a telephone appliance and requires the same grade of telephone wire, that the phone company uses. If installed outside, Out Side Plant wiring **MUST** be used. If installed underground, direct burial Out Side Plant wiring **MUST** be used. Do **NOT** use In Side Plant wiring, such as: Inside Cat 3, Cat 5, or JKT Inside wiring, in OUTSIDE installations.

A good grade of direct burial OSP wire cable in compliance with ANSI/ICEA S-96-634-1996 REA PE-86 or RUS PE-86 requirements is recommended.

Distances / gauges are shown in the table. This is for TOTAL distance. For example, if the telephone signal originates at the house, and the Select Gate is 1,000 feet away from the house phone connections, then the total distance is 2,000 feet; 1,000 feet from the phone company connection to the Select Gate, and 1,000 feet from the Select Gate to the house wiring, which in this example would require 2 pairs of 22 ga. wire.

Recommended wire gauge is as shown: 24ga. up to 1,000 feet.  
 22 ga. up to 5,000 feet.  
 19 ga. Up to 10,000 feet.

Out Side Plant Wiring under ground: use direct burial type BDW-G (RUS PE-86)  
 Out Side Plant Wiring above ground use weather proof type BDW-A (RUS PE-86)

Wire MFG.	Wire Usage	Wire Type Designation	24 ga (up to 1,000 ft dist.)	22 ga (up to 5,000 ft. dist.)	19 ga (up to 10,000 ft. dist.)
Superior/Essex	Above Grade	BDW-A (RUS PE-86)	04-098-85	04-055-84	02-023-85
Superior/Essex	Below Grade	BDW-A (RUS PE-86)	04-098-85	04-055-84	02-023-85
Superior/Essex	Gopher/Rodent	BDW-G (RUS PE-86)	04-094-16	04-055-17	04-030-16
General Cable	Below Grade	REA (RUS) PE-86	2095132	2095126	Not Available
General Cable	Gopher/Rodent	REA (RUS) PE-86	2095066	2095002	2095102

The above table lists some typical manufacturers and part numbers for this wire.

**3.1.4.1 CONNECTING RJ-31X**

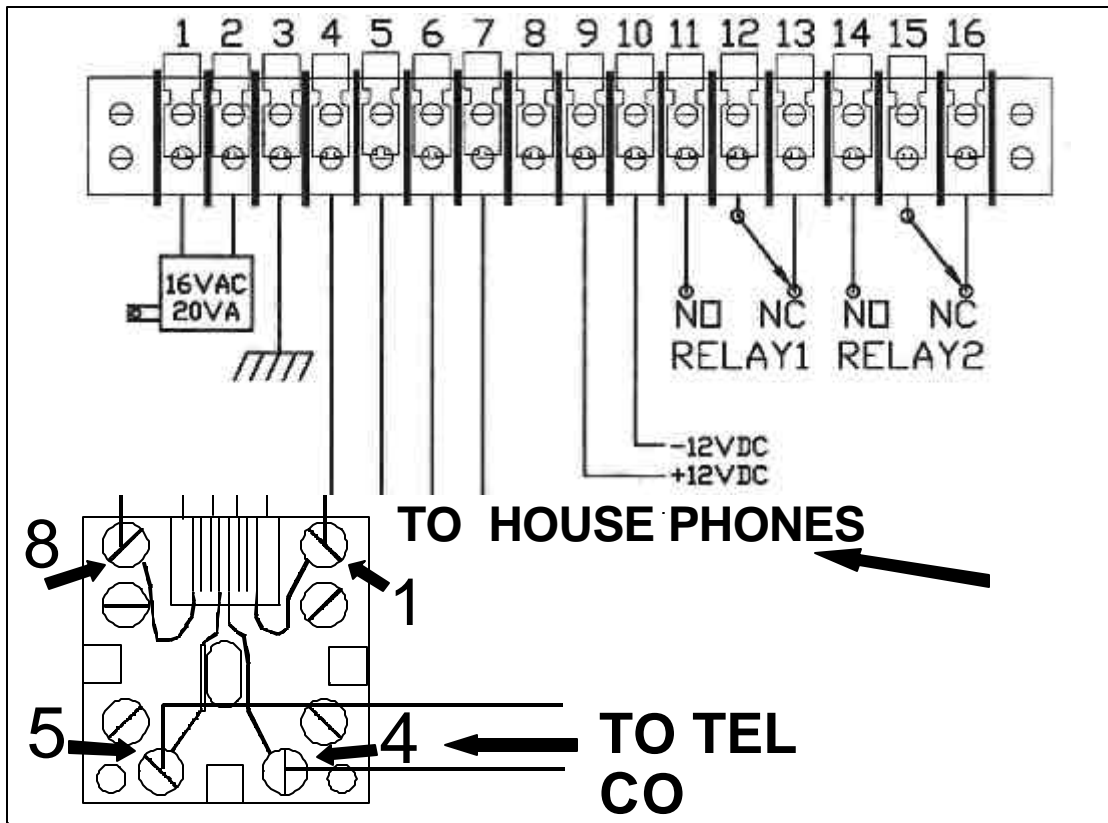

1) The Select Gate is provided with a USOC type RJ-31X jack and plug. Terminals 4 and 5 of the RJ-31X are the terminals that connect to the lines coming from the telephone company. They will usually be green and red in color. Make certain to connect the wires between the washers of the screw terminal and NOT under the screw head of the screw terminals. The line should measure approximately 48 to 52 volts DC across the wires coming from the phone company. Verify this before attaching wires to terminals 4 and 5.

2) Connect the wires going to the residence (the house phone wiring) to terminals 1 and 8 of the RJ-31X jack. These wires will be various colors, depending on the manufacturer of the jack, but probably slate and brown.

3) To verify correct connection, remove the RJ-31 plug from the jack. Check for continuity from terminal 1 to 4. Next check for continuity from terminal 5 to 8.

4) Plug the RJ-31 plug back into the jack. Next, check for 48 - 52 volts DC across terminals 4 and 5 (this is the telephone dial tone voltage).

**NOTE: THE RJ-31X JACK **MUST** BE WIRED CORRECTLY TO PREVENT DAMAGING TELEPHONE EQUIPMENT**

## 3.1.4.2 CONNECTING SELECT GATE TO HOMES WITH ALARM SYSTEM

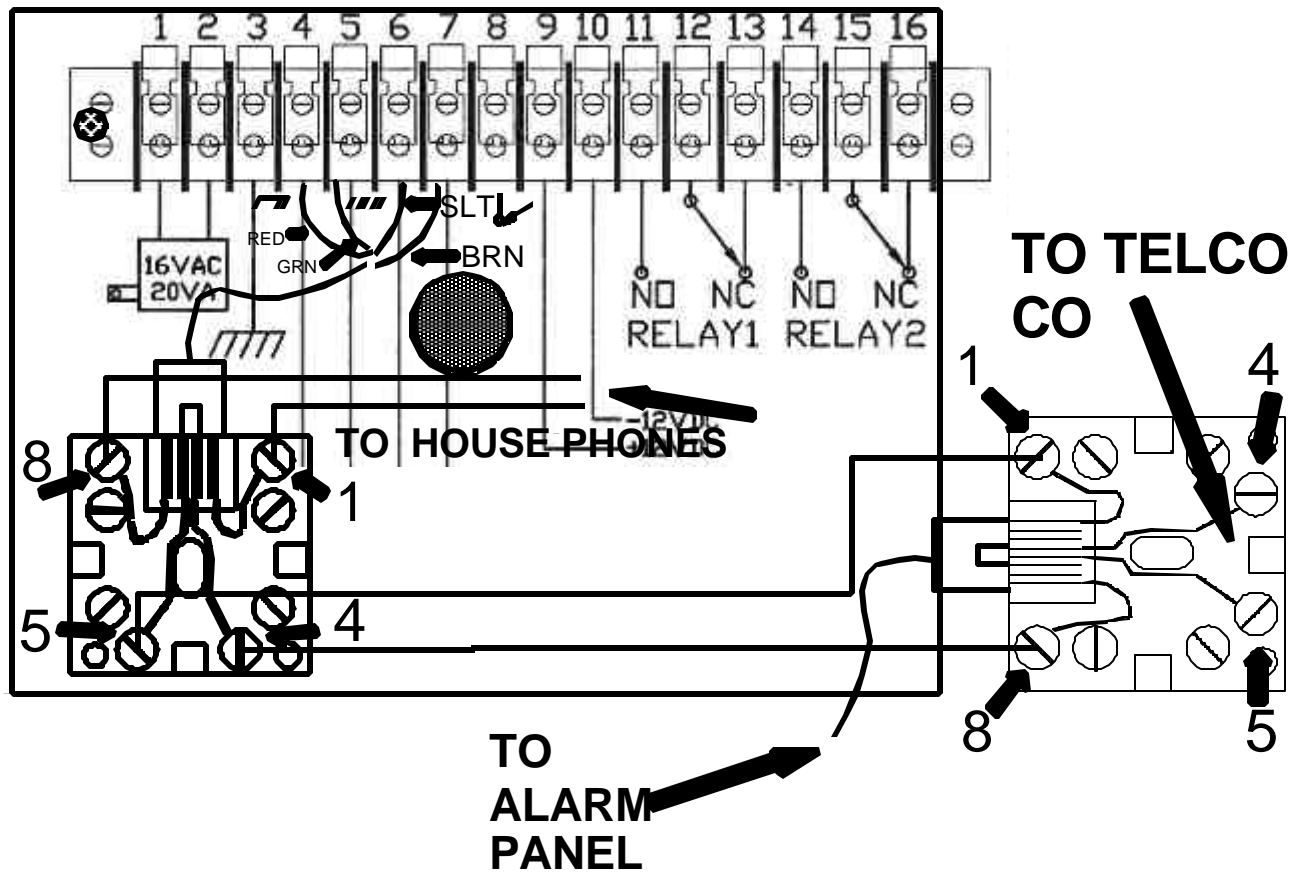

- 1) Connect the Select Gate input to the output of the alarm panel RJ-31X jack as shown above. This is to ensure that the Select Gate never inadvertently intercepts an alarm signal from the alarm panel's dialer.
- 2) Connect terminal 1 from the alarm panel RJ-31X to terminal 4 of the Select Gate -31X jack. Connect terminal 8 from the alarm panel RJ-31X to terminal 5 of the Select Gate -31X jack.
- 3) Connect the wires going to the residence (the house phone wiring) to terminals 1 and 8 of the RJ-31X jack. These wires will be various colors, depending on the manufacturer of the jack.
- 4) To verify correct connection, remove the Select Gate RJ-31 plug from the Select Gate jack. Check for continuity from terminal 1 to 4. Next check for continuity from terminal 5 to 8.
- 5) Plug the RJ-31 plug back into the jack. Next, check for 48 - 52 volts DC across terminals 4 and 5 (this is the telephone dial tone voltage).

**NOTE: THE SELECT GATE RJ-31X JACK MUST BE WIRED AFTER ANY ALARM PANEL OR OTHER SECURITY DIALER**



**3.1.5 CONNECTING DEVICES TO CONTROL RELAY**

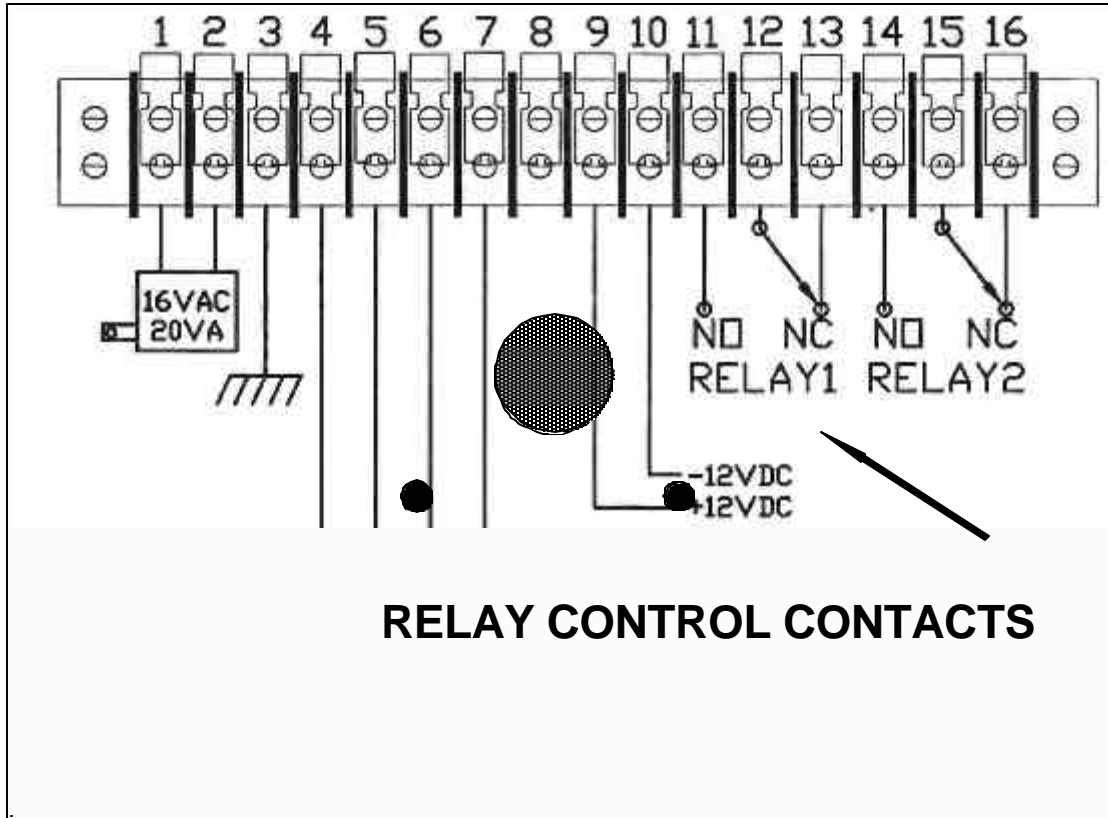

- 1) If you are using the N.O. contacts on Relay 1, connect the wires from the controlled device to TBS-11 and TBS-12, as shown above. To use the N.C. contacts, connect the wires from the controlled device to TBS-12 and TBS-13.
- 2) If you are using the N.O. contacts on Relay 2, connect the wires from the controlled device to TBS-13 and TBS-14, as shown above. To use the N.C. contacts, connect the wires from the controlled device to TBS-14 and TBS-15.
- 3) Remember these are dry contacts only and do not provide any voltage. Devices that require voltage such as door strikes and magnetic locks will require their own supply voltage, which will be switched on and off by the Select Gate control relay.
- 4) Some solid-state gate controllers react to the over-voltage protection devices used on all SES products. This is a gate controller dependent problem. The symptom is an intermittent gate open condition, or gate stuck open condition, sometimes occurring after using the latching function. If this occurs, add an external relay controlled by the Select Gate output relay contacts to your gate system. This will help isolate the contacts going to your solid state gate controller.

**NOTE: THE RELAY CONTACTS ARE RATED FOR 24 VOLTS AC OR DC AT 2 AMPS**

3.1.6 REX INPUTS

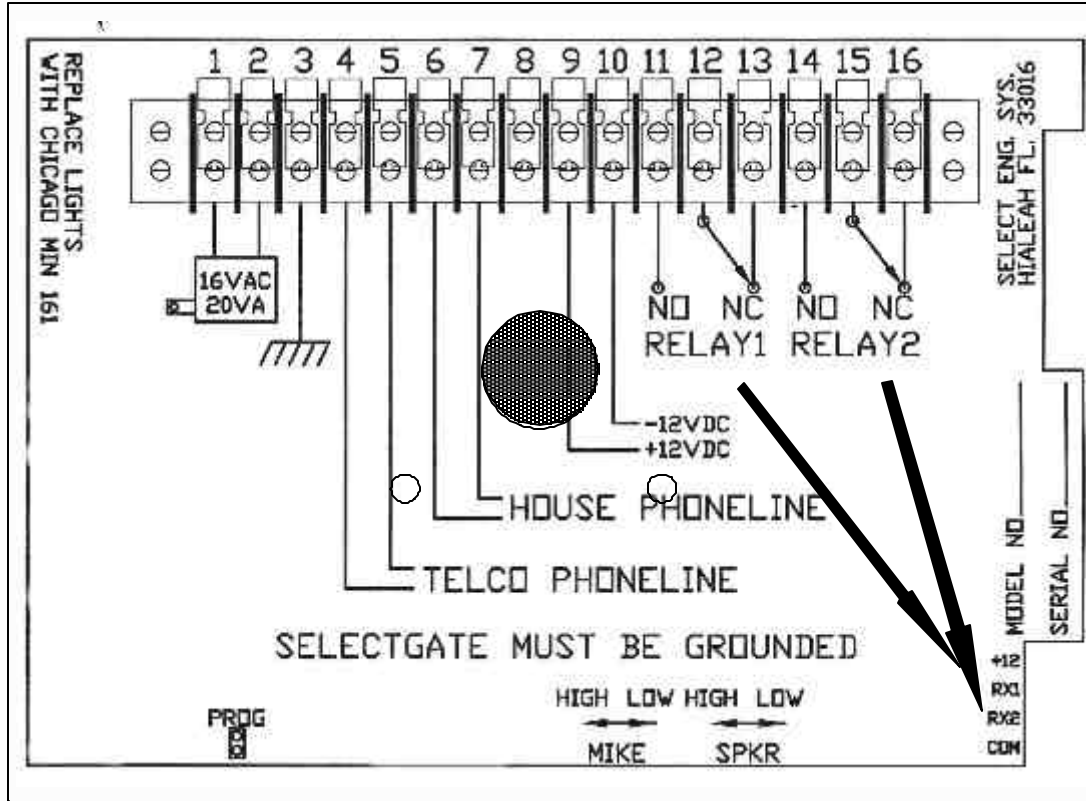

The Request to Exit (REX) input is a normally open dry contact input. When RX1 and COM are closed, a signal is sent to Relay 1, which then energizes for the programmed time. When RX2 and COM are closed, a signal is sent to Relay 2, which then energizes for the programmed time.

# SELECT GATE SG-1A V1.X

## 3.1.7 ADJUSTING SPEAKER VOLUME

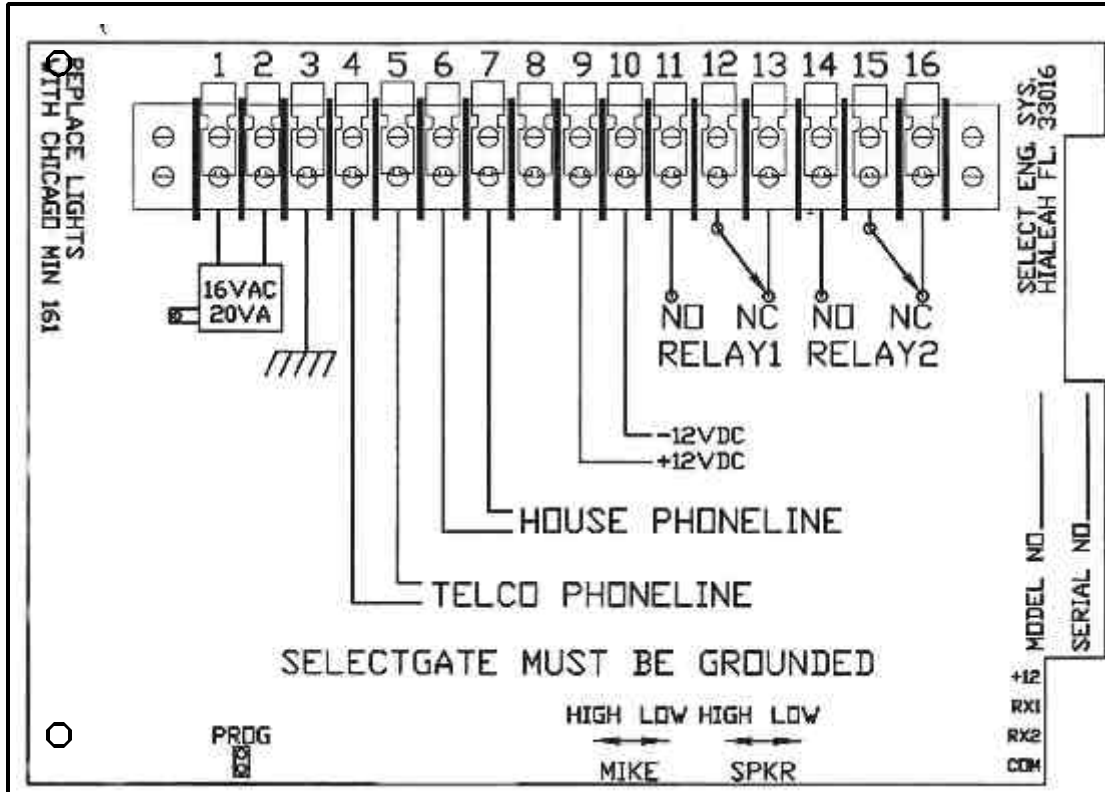

To adjust the speaker volume, move the white nylon wheel in the desired direction. See diagram above. A good way to make the adjustment is to press the "\*" key and adjust the white nylon speaker adjust wheel. When a moderate beep is heard, there should be adequate voice audio level. Make any final adjustments by calling the house from Select Gate.

3.1.8 ADJUSTING MICROPHONE SENSITIVITY

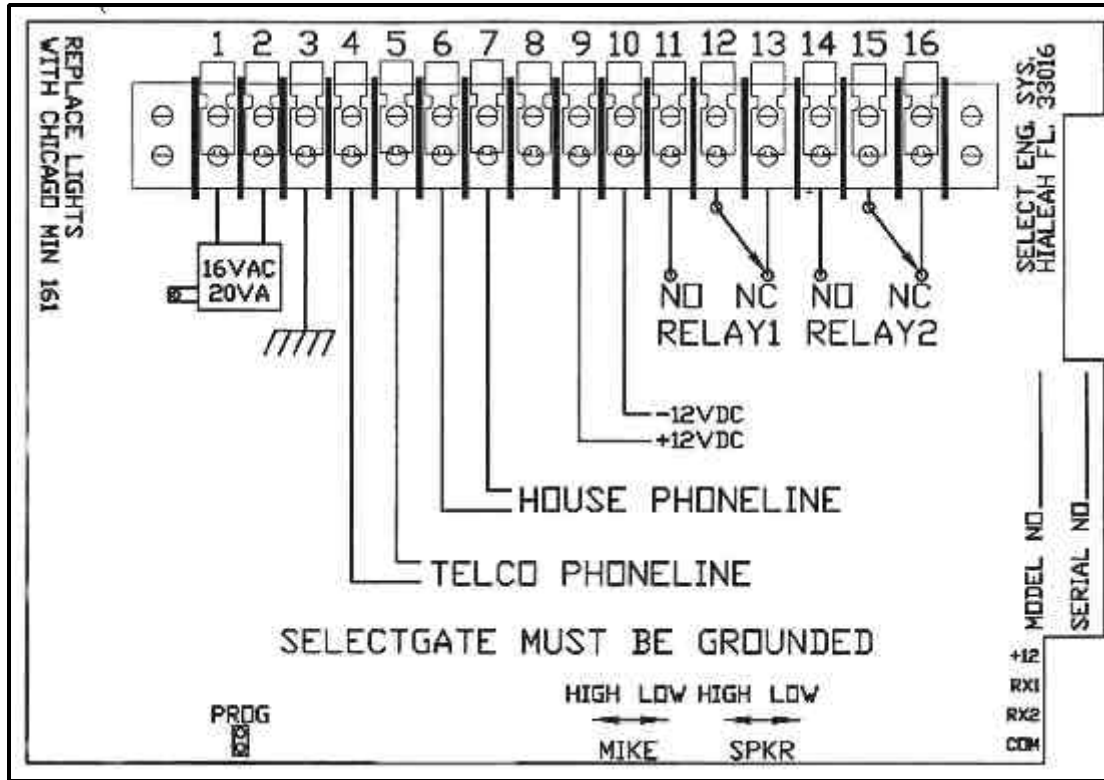

To adjust the microphone sensitivity, move the white nylon wheel in the desired direction. See diagram above. The microphone sensitivity adjusts the point at which Select Gate switches from speaker to microphone. It also adjusts the microphone volume within a more narrow range than the speaker adjustment control. For this reason, care must be taken to avoid extremes of adjustment. Otherwise, either the microphone or the speaker may be unable to switch on until the controls are more balanced.

To get into the general range of adjustment, call the house from Select Gate. Have someone in the house count from 1 to 10 while brushing your fingertip back and forth over the microphone hole. This is to the left of the call button. When you hear some of the syllables begin to miss (because the microphone circuit is cutting off the speaker), you have the microphone adjusted. Fine tune the adjustment by conversing back and forth normally and making any further adjustments as required.

### **3.1.9 CHANGING SELECT GATE BULB**

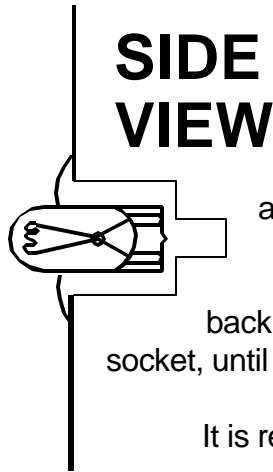

The Select Gate has two light bulbs, one on either side of the Select Gate front panel. These are Chicago Miniature Lamp type 161 light bulbs. They are rated at 14 volts at 190 ma. each. They are run at a lesser voltage to increase their operational life-time. These lamps may be replaced with similar equivalents from national electronics chain stores or automotive supply stores. They also are available from SES (part # 305T3R25161).

To change the light bulb, pull the light bulb out of it's socket by pulling from the back plate toward the face plate. Insert the new light bulb by pressing down into the socket, until the bulb seats.

It is recommended that both light bulbs be replaced whenever a light bulb is needed.

## 4.0 INITIALIZATION AND PROGRAMMING

Initialization refers to configuration of a Select Gate. This is done during installation and may include how long the door entry time is, or what Touch-Tone number energizes the door control relay. These tasks are generally performed by the installer of the Select Gate.

Programming refers to the entry of codes, phone numbers, and PIN (Personal Identification Numbers). This data is generally entered by the end user or customer, and is updated periodically as required.

### 4.1 CONFIGURING SELECT GATE

Select Gate can be entirely configured from the keypad. No internal adjustments are required.

To begin configuring Select Gate, a programming mode must be entered. Do this by pressing the "\*" and the "0" keys simultaneously as shown at right. You will hear two beeps (••).

If you get a dial tone you missed the "\*", and if you get a single beep (•), you missed the "0".

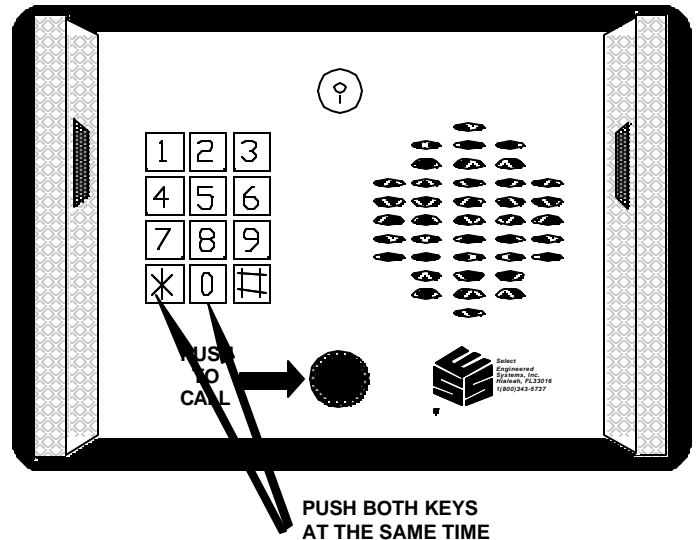

After you hear the two beeps, you have approximately 10 seconds to begin entering the 4 digit password. All Select Gates leave the factory with a password of 7 7 7 7. Press the "7" key four times as shown at right. Then press the "\*" key. After each key press you will hear an acknowledgment beep (•) to show the key actually made contact. If the password is entered correctly, you will hear the final acknowledgment beep of the "\*" and three beeps (• •••). This indicates that you are now in program mode.

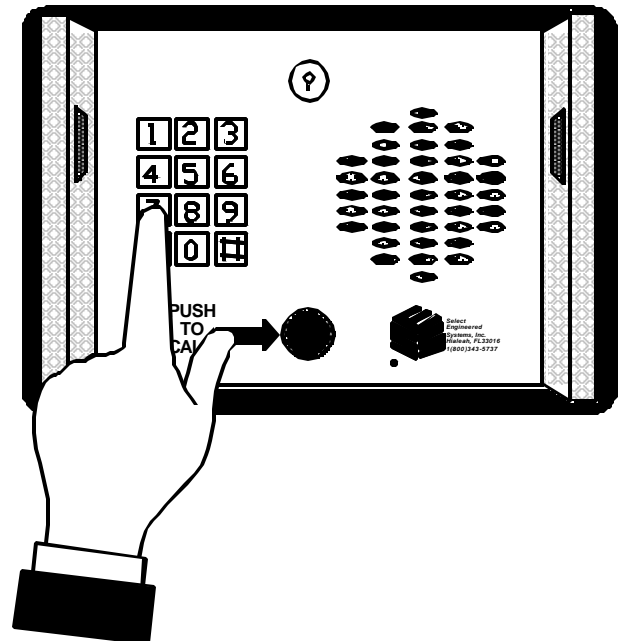

**TO EXIT PROGRAM MODE  
PRESS THE "\*" AND THE "0" KEY  
AT THE SAME TIME.**

**4.2 FACTORY DEFAULTS AND PROGRAMMING FUNCTIONS**

Listed below are all the default factory parameters of Select Gate. The number to the right of the default description refers to the section in this manual where changing the default is described. All these default changes assume that programming mode has already been entered from either the keypad or a phone, either in the house or residence or from an outside line.

<b>DESCRIPTION</b>	<b>RANGE</b>	<b>PARAMETERS</b>	<b>DEFAULT</b>
11	Phone Code	0 - 9	
12	Pin Code	00 - 99	WW XXXX Y Z
21	Relay 1 Unlock Tone	0 - 9	6
22	Relay 1 Latch Tone	0 - 9	0
23	Relay 1 1 Hour Unlock Tone	0 - 9	0
24	Relay1 Open Time	00 - 99 seconds	2
26	Strike out Count	0 - 9	0
27	Lock Out Time	0 - 4 minutes	0
31	Relay 2 Unlock Tone	0 - 9	0
32	Relay 2 Latch Tone	0 - 9	0
33	Relay 2 1 Hour Unlock Tone	0 - 9	0
34	Relay 2 Open Time	00 - 99	0
41	Ring Type	1 - 4	SS SL LS LL 1 (SS)
42	Ring Count	1 - 9	
44	Call Waiting Type	1 - 4	SS SL LS LL 1(SS)
45	Ring Detect	00 - 99	09
46	Back Beep	0 - 1	0
47	Talk Time	1 - 9 minutes	1
48	Keypad On	0 - 1	0
51	Programming Password	4 digits	7777
61	Call Forward Tone	0 - 9	0
62	Call Forward Type		
64	Call Forward Number		Up to 16 digits
65	Call Forward ON/OFF	0 - 1	0
91	Clear All Phones		

92	Clear All Pins			
94	Preset Relays			
96	Set Call Forward			
99	Preset All Memory			

**NOTE: ALL SELECTIONS IN SECTION 4.2 ASSUME SELECT GATE IS ALREADY IN PROGRAMMING MODE.**

#### 4.2.1 PIN CODES (Function 12)

On the Select Gate the PIN length is 4 digits. To set a PIN code requires a 2 digit code (where the PIN is stored in the Select Gate), the 4 digit PIN itself, an action code for the relay and a time zone (in future versions) There can be up to 100 pin codes in a Select Gate.

Example: To set a pin code to 1234, from Programming mode, key in 12 01 1234 0 0. This puts the PIN number 1234 in location 01 and will always open relay 1.

1 + 2 + 0 1  
 + 1 + 2 + 3 + 4 + 0 + 0 + ✕

**To remove a PIN number:** Press 12 01 0000 00 \*. 1234 is no longer valid.

#### 4.2.2 PHONE CODES (Function 11)

The Select Gate can dial up to 10 phone numbers that can be up to 16 digits in length including pauses. Each 2 second pause counts as a digit. To set a phone from Programming mode, key in 11, a number from 0 - 9 (the phone code), and the phone number itself. To program a pause, use the # key. A pause is approximately 2 seconds long.

Here is an example of programming a phone number 765-4321 into location 0:

1 + 1 + 0  
7 + 6 + 5 + 4 + 3 + 2 + 1 + ✕

**To remove a phone code:** Press 110 # \*. 7654321 is no longer valid.



**4.2.3 RELAY 1 UNLOCK TONE (Function 21)**

This is the Touch-Tone™ number that the house would press to activate relay 1 on the Select Gate for the programmed unlock time. This time is from 1 to 99 seconds. Any single Touch-Tone™ from 1 through 9 may be used to energize relay 1. Touch-Tone™ 0 is used to disable functions on the Select Gate.

To change from the default of 6 to 1:

**2** + **1** + **1** + 

**4.2.4 RELAY 1 LATCH TONE ( Function 22)**

This is the Touch-Tone™ number that the house would press, after calling the Select Gate and entering the 2 digit control password, in order to activate relay 1 on the Select Gate for unlimited time. Any single Touch-Tone™ from 1 through 9 may be used to energize relay 1. Touch-Tone™ 0 is used to disable functions on the Select Gate.

To change from the default of 0 (disabled) to 4:

**2** + **2** + **4** + 

**4.2.5 RELAY 1 ONE HOUR TONE (Function 23)**

Relay 1 is energized for one hour when the house calls Select Gate, enters the 2 digit control password and presses a valid one hour unlock Touch-Tone™.

To change from the default of 0 (disabled) to 7:

**2** + **3** + **7** + 

**4.2.6 RELAY 1 OPEN TIME (Function 24)**

This is the length of time that relay 1 is energized when the house presses a valid unlock tone. This time can be programmed from 1 to 99 seconds.

To change from the default of 2 seconds to 5 seconds:

**2** + **4** + **0** + **5** + 

Note the leading "0" for time less than 10 seconds.

**NOTE: IF LEADING 0 FOR TIME LESS THAN 10 SECONDS IS NOT ENTERED, TIME WILL NOT CHANGE FROM PREVIOUS SETTING.**

**4.2.7 STRIKE OUT COUNT (Function 26)**

Strike out count is the number of times from 1 to 9 an incorrect PIN code can be entered before lock out occurs. This means that Select Gate will no longer respond to keypad input, until the lock out time expires. The lock out length of time is from 1 to 4 minutes.

To change the strike out count from the default of 3 strikes to 5 strikes:

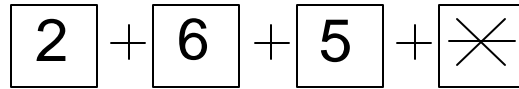
**4.2.8 LOCK OUT TIME (Function 27)**

Lock out time is the time in minutes from 1 to 4 minutes that the keypad does not respond to key presses. This is to keep the PIN codes from being "guessed".

To change the lock out time from the default of 1 minute to 3 minutes:

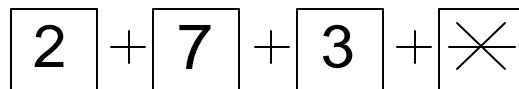
**4.2.9 RELAY 2 UNLOCK TONE (Function 31)**

This is the Touch-Tone™ number that the house would press in order to activate the optional relay 2 on the Select Gate for the programmed unlock time. This time is from 1 to 99 seconds. Any single Touch-Tone™ from 1 through 9 may be used to energize relay 2. Touch-Tone™ 0 is used to disable functions on the Select Gate.

To change from the default of 0 (disabled) to 2:

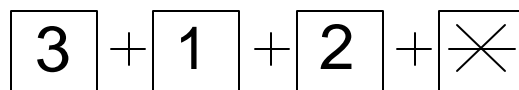

**NOTE: IF THE SAME TOUCH-TONE™ NUMBER IS USED FOR RELAY 1 AND RELAY 2, BOTH RELAYS WILL ENERGIZE AT THE SAME TIME.**

**4.2.10 RELAY 2 LATCH TONE (Function 32)**

This is the Touch-Tone™ number that the house would press, after calling the Select Gate and entering the 2 digit control password, in order to activate relay 2 on the Select Gate for unlimited time. Any single Touch-Tone™ from 1 through 9 may be used to energize relay 2. Touch-Tone™ 0 is used to disable functions on the Select Gate.

To change from the default of 0 (disabled) to 5:

**3** + **2** + **5** + 

**NOTE: IF THE SAME TOUCH-TONE™ NUMBER IS USED FOR RELAY 1 AND RELAY 2, BOTH RELAYS WILL LATCH AT THE SAME TIME.**

**4.2.11 RELAY 2 ONE HOUR TONE (Function 33)**

Relay 2 is energized for one hour when the house calls Select Gate, enters the 2 digit control password and presses a valid unlock Touch-Tone™.  
To change from the default of 0 (disabled) to 8:

**3** + **3** + **2** + 

**4.2.12 RELAY 2 OPEN TIME (Function 34)**

This is the length of time that relay 2 is energized when the house presses a valid unlock tone. This time can be programmed from 1 to 99 seconds.  
To change from the default of 10 to 5:

**3** + **4** + **0** + **5** + 

Note the leading "0" for time less than 10 seconds.

**4.2.13 RING TYPE (Function 41)**

There are 4 types of ring combinations for ringing the house or residence phone. This makes it easy to determine if a call is from an outside line or from the Select Gate location. The four combinations are shown in the table below:

RING TYPE	
1	SHORT SHORT
2	SHORT LONG
3	LONG SHORT
4	LONG LONG

To change from the default of Ring Type 1 (short short) to Ring Type 3 (long short):

$$\boxed{4} + \boxed{1} + \boxed{3} + \boxed{\times}$$

#### 4.2.14 RING COUNT (Function 42)

Ring count is the number of times Select Gate will ring the house or residence before it hangs up.

If there are any other devices attached to the phone line such as answering machines that you do not want to have answer the Select Gate, then set the Select Gate ring count number to a number lower than those devices require. This will allow those devices to answer first.

To change the default from 9 rings to 3 rings (3 being less than the number of rings at which most answering machines pick up):

$$\boxed{4} + \boxed{2} + \boxed{3} + \boxed{\times}$$

#### 4.2.15 CALL WAITING TYPE (Function 44)

If the Select Gate has called the house or residence and a call comes in from an outside line, the Select Gate will issue 1 of 4 possible combinations of beeps. This is to alert you so that the "#" key can switch to the outside call. The call waiting types are shown in the table below:

CALL WAITING TYPE	
1	Short Short
2	Short Long
3	Long Short
4	Long Long

To change from the default of Call Waiting Type 1 (Short Short) to Call Waiting Type 3 (Long Short):

$$\boxed{4} + \boxed{4} + \boxed{3} + \boxed{\times}$$

#### 4.2.16 RING DETECT (Function 45)

Ring detect is the number of times from 01 to 99 that the Select Gate allows the house phone to ring before it goes off hook and answers. If there are any other devices attached to the phone line such as answering machines that need a higher priority than Select Gate, then set the Select Gate ring detect number to a number higher than those devices require. This will allow those devices to answer first.

To change the ring detect from the default of 9 rings to 15 rings:

$$\boxed{4} + \boxed{5} + \boxed{1} + \boxed{5} + \boxed{\times}$$

## **SELECT GATE SG-1A V1.X**

---

If less than 10 rings are required don't forget to put a "0" in front of the ring (05 not 5).

### **4.2.17 BACK BEEP (Function 46)**

Back beep is a function that puts a tone onto the phone line every ten seconds, whenever the Select Gate has called an out side phone line. This allows someone called on an outside phone line to know that the caller is calling from the Select Gate.

To change Back beep from the factory default of disabled (0) to enabled (1):

**4** + **6** + **1** + 

### **4.2.18 TALK TIME (Function 47)**

Talk time is the time the Select Gate stays energized when calling a number on the outside line. (Not the house.) The range is from 1 to 9 minutes

To change from the default of 1 minute to 5 minutes:

**4** + **7** + **5** + 

### **4.2.19 KEYPAD ON (Function 48)**

This function, when enabled keeps the Select Gate keypad active for keying in the Touch Tone numbers 0 - 9. \* and # are not allowed.

To change from the default of 0 (off) to 1 (on): :

**4** + **8** + **1** + 

### **4.2.20 PROGRAMMING PASSWORD (Function 51)**

This is the 4 digit number that allows all parameters, function definitions, PIN codes, phone numbers, timers, and all programmable features to be changed.

To change from the default password number 7777 to 4321:

**5** + **1** + **4** + **3** + **2** + **1** + 

**4.2.21 CALL FORWARD TONE (Function 61)**

This feature permits remote control of the call forward number to forward a call to some location other than the house or residence. This feature is controlled by programming from a Touch-Tone™ phone either at the house, or from an outside line.

**6** + **1** + **8** + 

To change call forwarding tone from 0 (disabled) to another tone (ex. 8):

**4.2.22 CALL FORWARD TYPE (Function 62)**

When this feature is enabled, it dials a previously programmed number to forward a call to some location other than the house or residence. This feature is controlled by programming from a Touch-Tone™ phone either at the house, or from an outside line. Depending on how Select Gate is programmed, it will send a one ring notification of call forwarding to the house, or it will forward the call without notification.

To set call forwarding to forward without notification:

**6** + **2** + **0** + 

To set call forwarding to forward with notification:

**6** + **2** + **1** + 

**4.2.23 CALL FORWARD NUMBER (Function 64)**

The number to dial when the call forward feature is enabled, can be from 1 to 16 digits.

To add a number to call forward (we will use as an example, a 10 digit phone number: 305-565-4321):

**6** + **4** + **3** + **0** + **5**  
**5** + **6** + **5** + **4** + **3** + **2** + **1** + 

**4.2.24 CALL FORWARD ON/OFF (Function 65)**

This feature permits remote control of the call forward number to be enabled or disabled. This feature is controlled by programming from a Touch-Tone™ phone either at the house, or from an outside line.

To change call forwarding tone from 0 (disabled) to enabled (1):

**6** + **5** + **1** + **✕**

**4.2.25 CLEAR ALL PHONES (Function 91)**

To clear all programmed phone numbers from the Select Gate, press the sequence 91 followed by 1010 and \*. The 1010 is to keep from inadvertently erasing any functions by accident.

**9** + **1** + **1** + **0** + **1** + **0** + **✕**

**4.2.26 CLEAR ALL PINS (Function 92)**

To clear all programmed PIN Codes from the Select Gate, press the sequence 92 followed by 1010 and \*. The 1010 is to keep from inadvertently erasing any functions by accident.

**9** + **2** + **1** + **0** + **1** + **0** + **✕**

**4.2.27 PRESET ALL RELAYS (Function 94)**

To clear all programmed relay parameters from the Select Gate, press the sequence 94 followed by 1010 and \*. The 1010 is to keep from inadvertently erasing any functions by accident. This will set all relay functions and times back to factory defaults.

**9** + **4** + **1** + **0** + **1** + **0** + **✕**

**4.2.28 CLEAR ALL CALL FORWARD PARAMETERS (Function 96)**

To clear all programmed call forward phone numbers from the Select Gate, press the sequence 96 followed by 1010 and \*. The 1010 is to keep from inadvertently erasing any functions by accident.

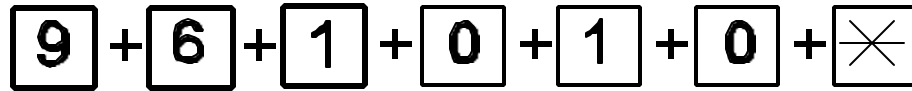
**4.2.29 PRESET ALL MEMORY (Function 99)**

To clear EVERYTHING ever programmed into the Select Gate, press the sequence 99 followed by 1010 and \*. The 1010 is to keep from inadvertently erasing any functions by accident. This will set ALL operating parameters back to the factory default. **Select this function with care.**

**4.3 EXITING PROGRAM MODE**

To exit program mode from the keypad on the front of the Select Gate, press the "\*" and the "0" keys simultaneously. If you do not press any key for 60 seconds, the Select Gate will automatically exit program mode.



**5.0 SELECT GATE OPERATION**

**5.1 SELECT GATE CALLING HOUSE**

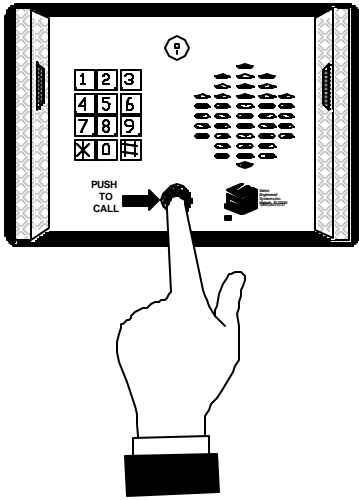

Select Gate starts operation when someone presses the call button as shown at left, or presses the "#" key on the keypad. This causes the Select Gate to ring the house or residence. The ringing pattern may be different from calls placed from outside phones.

Select Gate has one of 4 ringing patterns, as shown in the table below:

RING TYPE	
1	SHORT SHORT
2	SHORT LONG
3	LONG SHORT
4	LONG LONG

It may be helpful to have your installer indicate which ring type has been programmed for your Select Gate (See Appendix A Pg. 33-35). The ring type may be re-programmed at any time.

When your phone rings you will be able to distinguish calls placed from the Select Gate as opposed to calls placed from outside lines.

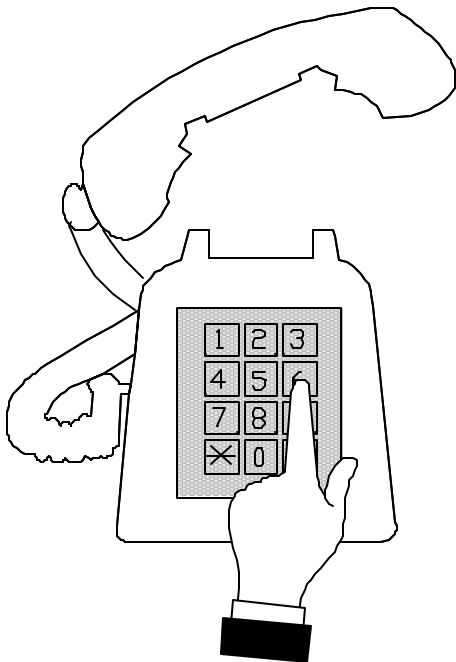

Answer the ring from any Touch-Tone™ phone in the house. Conversation at the Select Gate location is hands free. After identifying the caller, if access is permitted, press whatever key has been programmed to open the Select Gate. Press the key BEFORE you hang up the phone. This number will usually be a "6". If your installer has changed the timed entry number, locate that number from the Customer Setup chart in Appendix A on Pg. 33-35. Use that number as shown at left to open the Select Gate entrance.

## 5.2 SELECT GATE CALLING HOUSE WHEN PHONE IN USE

If you are using the phone when someone calls from the Select Gate, you can transfer from the outside line call and the Select Gate call. You will hear a beep pattern in the background. This will be 1 of 4 combinations depending on how your Select Gate is programmed.

When you hear that beep, tell whoever you were talking to, to hold for a moment and press the "\*" or "#" key as shown at right. This will transfer your house phone to the Select Gate.

Open the Select Gate as in the previous section by pressing "6" on your phone. The Select Gate will open and you will be immediately transferred back to your original call.

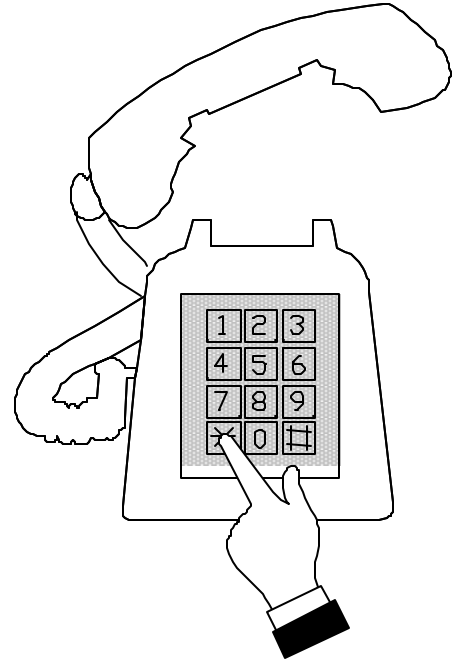

## 5.3 SELECT GATE CALLING OUTSIDE PHONE

Select Gate can call up to 10 different phone numbers. These numbers must be previously programmed into Select Gate. These phone numbers are referenced by a code number. This code number is 1 digit.

After Select Gate has placed the call, the called party may press a Touch-Tone™ "6". This will open the entrance, just as if the house had pressed a "6".

In the example at right, pressing a "3" (assuming a code length of 1) will dial whatever phone number was programmed into code number 3. This phone number may be up to 14 digits in length. This makes it possible to dial long distance phone numbers.

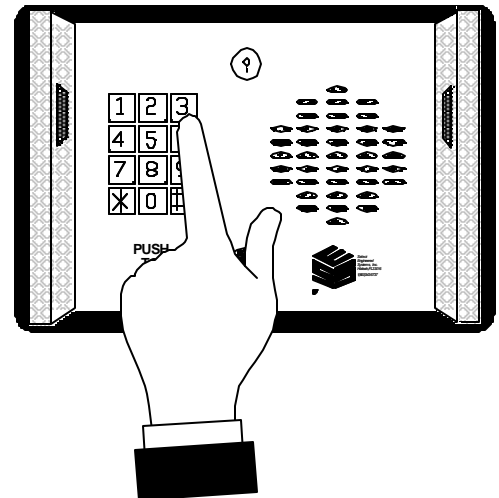

**5.4 SELECT GATE USING PIN CODES**

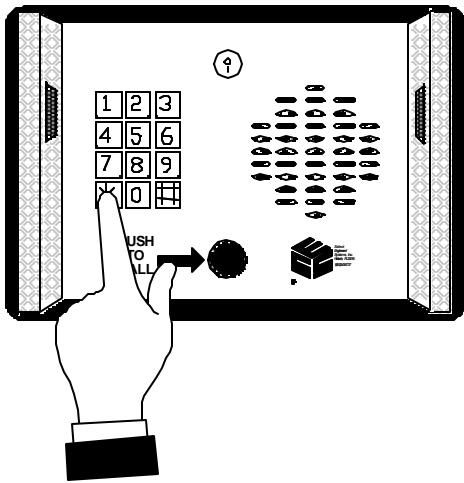

In addition to opening the entrance from the house or from a remote location, Select Gate can operate the entrance from the keypad. This is done with a PIN (Personal Identification Number) code. This is a 4 digit number. When the "\*" key is pressed, (as shown at left) followed by the PIN code, the entrance will open.

In this example, a PIN code of 1234 will open the Select Gate entrance.



**5.5 CALLING SELECT GATE FROM HOUSE**

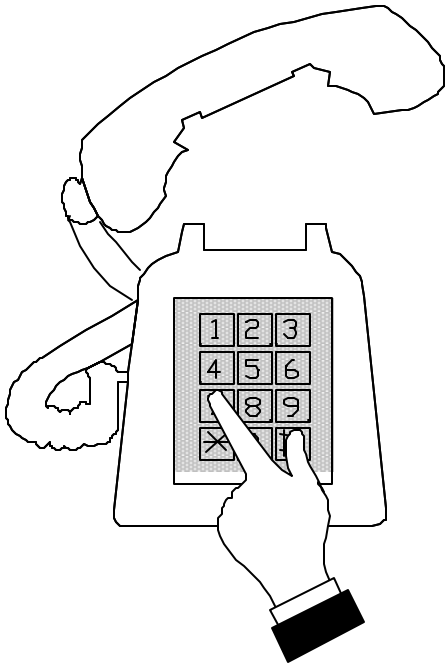

There are remote control functions built into the Select Gate that allow the entrance relay to be controlled in different ways. The entrance may be latched in an open condition, or it may be energized for one hour. In addition to the door open number, (which is usually a "6") numbers may have been entered by your installer for a latch number and a one hour number. Refer to the Customer Setup chart in Appendix A on Pg. 33-35 for the correct Touch-Tone™ numbers to use from your phone to energize the relay for these functions.

In order to access these functions, the house must call the Select Gate and enter a remote control password which is the first 2 digits of the program password, and will usually be "7 7". If your installer has changed the password, refer to the Customer Setup chart in Appendix A on Pg. 33-35 for the correct Remote Control password. It will be the first two digits of the Programming Password.

Pick up any Touch-Tone™ phone, wait one second and dial the remote control password as shown below:

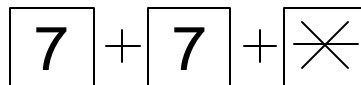

You have five seconds to dial in the password.

After the correct password has been entered, you will hear 1 beep (•). Now enter the appropriate number to latch the entrance. The speaker and microphone are also active at this time to permit conversation. Any combination of relay functions may be keyed in, until the house phone hangs up.

## 5.6 PROGRAMMING SELECT GATE FROM HOUSE

There are remote programming functions built into the Select Gate that allow the entrance control to be configured in different ways. For example, call forwarding may be enabled, so that when no one is home, anyone pressing the call button on Select Gate will have the call dial out to whatever phone number has been programmed into call forwarding by your installer. Refer to the Customer Setup chart in Appendix A on Pg. 33-35 for whatever call forwarding number was entered. These operating choices may be re-programmed at any time.

In order to access these functions, the house must call the Select Gate and enter a remote programming password. This password is 4 digits long and will usually be "7777".

If your installer has changed the password, refer to the Customer Setup chart in Appendix A on Pg. 33-35 for the correct remote programming password.

Pick up any Touch-Tone™ phone, wait one second and dial the remote programming password as shown below:

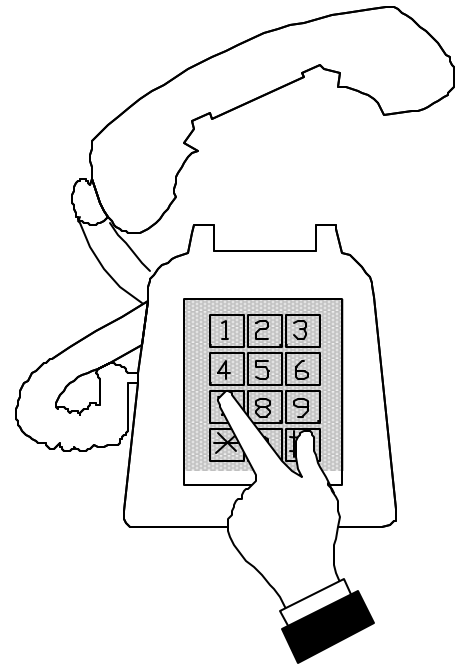

After lifting the handset, you have approximately 5 seconds to begin entering the 6 digit password. All Select Gates leave the factory with a password of 7 7 7 7. Press the "7" key four times as shown above. Then press the "\*" key. If the password is entered correctly, you will hear three beeps (•••). This indicates that you are now in program mode.

All the functions described in Section 4.2 are programmed exactly the same from the telephone keypad as they are from the Select Gate keypad.

### 5.6.1 PROGRAMMING SELECT GATE FROM OUTSIDE PHONE

In the same way that you just programmed the Select Gate from the house, you can also program it from an outside phone, (from your office for example). Just remember that the factory default for Select Gate to answer the phone line is 9 rings. If someone is at the house, they will have to be notified not to answer the phone until programming is complete. Call the Select Gate using the phone number it is connected to, and after it answers, enter the 4 digit password and follow the procedure just like Section 5.6.

### 5.6.2 EXITING PROGRAM MODE

To exit program mode from the house phone simply hang up. To exit program mode from the keypad on the front of the Select Gate, press the "\*" and the "0" keys simultaneously.

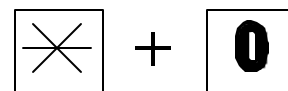

## APPENDIX A CUSTOMER SETUP CHART

DESCRIPTION	RANGE	PARAMETERS	DEFAULT
11	Phone Code	0 - 9	
12	Pin Code	00 - 99	WW XXXX Y Z
21	Relay 1 Unlock Tone	0 - 9	6
22	Relay 1 Latch Tone	0 - 9	0
23	Relay 1 1 Hour Unlock Tone	0 - 9	0
24	Relay1 Open Time	00 - 99 seconds	2
26	Strike out Count	0 - 9	0
27	Lock Out Time	0 - 4 minutes	0
31	Relay 2 Unlock Tone	0 - 9	0
32	Relay 2 Latch Tone	0 - 9	0
33	Relay 2 1 Hour Unlock Tone	0 - 9	0
34	Relay 2 Open Time	00 - 99	0
41	Ring Type	1 - 4	SS SL LS LL
42	Ring Count	1 - 9	
44	Call Waiting Type	1 - 4	SS SL LS LL
45	Ring Detect	00 - 99	09
46	Back Beep	0 - 1	0
47	Talk Time	1 - 9 minutes	1
48	Keypad On	0 - 1	0
51	Programming Password	4 digits	7777
61	Call Forward Tone	0 - 9	
62	Call Forward Type	0 = No notification	1 = House notification
64	Call Forward Number	16 digits	0
65	Call Forward ON/OFF	0 - 1	0
91	Clear All Phones		911010*
92	Clear All Pins		921010*
94	Preset Relays		941010*
96	Set Call Forward		961010*
99	Preset All Memory		991010*

RING TYPE	
1	SHORT SHORT
2	SHORT LONG
3	LONG SHORT
4	LONG LONG

CALL WAITING	TYPE
1	SHORT SHORT
2	SHORT LONG
3	LONG SHORT
4	LONG LONG

## APPENDIX A CUSTOMER SETUP CHART

FUNCTION	RANGE	FACTORY DEFAULT	CUSTOMER SETTING
RELAY 1 UNLOCK TONE	0 - 9	6	
RELAY 1 LATCH TONE	0 - 9	0 (DISABLED)	
RELAY 1 OPEN TIME	01 - 99 SECONDS	10 SECONDS	
RELAY 1 1 HOUR OPEN TONE	0 - 9	0 (DISABLED)	
RELAY 2 UNLOCK TONE	0 - 9	0 (DISABLED)	
RELAY 2 LATCH TONE	0 - 9	0 (DISABLED)	
RELAY 2 OPEN TIME	01 - 99 SECONDS	10 SECONDS	
RELAY 2 1 HOUR OPEN TONE	0 - 9	0 (DISABLED)	
CALL FORWARD ENABLE	0 - 1	0 (DISABLED)	
CALL FORWARD NUMBER	1 - 16		

**APPENDIX A CUSTOMER SETUP CHART**

<b>PIN NUMBER</b>	<b>PIN NUMBER</b>	<b>PIN NUMBER</b>	<b>PIN NUMBER</b>	<b>PIN NUMBER</b>
1	2	3	4	5
6	7	8	9	10
11	12	13	14	15
16	17	18	19	20
21	22	23	24	25
26	27	28	29	30
31	32	33	34	35
36	37	38	39	40
41	42	43	44	45
46	47	48	49	50
51	52	53	54	55
56	57	58	59	60
61	62	63	64	65
66	67	68	69	70
71	72	73	74	75
76	77	78	79	80
81	82	83	84	85
86	87	88	89	90
91	92	93	94	95
96	97	98	99	00
<b>PHONE CODES (10 AVAILABLE)</b>		<b>PHONE NUMBERS</b>		<b>FOR SERVICE CALL:</b>

## APPENDIX B: SELECT GATE QUICK PROGRAMMING GUIDE

11 ADD PHONE NUMBER (11+ X + XXXXXXXXXXXXXXXX\*)  
 11 (0-9) \* DELETE SINGLE PHONE NUMBER.  
 12 ADD PIN NUMBER (12 + XX + XXXX+ 00 +\*)  
 12 00 0000 00 \* DELETE SINGLE PIN CODE  
 91 CLEAR ALL CODES AND PHONE NUMBERS (91 + 1010 + \*)  
 92 CLEAR ALL PINS (92 + 1010 + \*)  
 99 CLEAR EVERYTHING (99 + 1010 + \*)

21 + 0-9 RELAY 1 UNLOCK TONE  
 22 + 0-9 RELAY 1 LATCH TONE  
 23 + 0-9 RELAY 1 ONE HOUR UNLOCK TONE  
 24 + 00-99 RELAY 1 OPEN TIME  
 26 + 0-9 STRIKE OUT COUNT  
 27 + 0-9 LOCK OUT TIME IN MINUTES

31 + 0-9 RELAY 2 UNLOCK TONE  
 32 + 0-9 RELAY 2 LATCH TONE  
 33 + 0-9 RELAY 2 ONE HOUR UNLOCK TONE  
 34 + 00-99 RELAY 2 OPEN TIME

41 + 1-4 RING TYPE (SEE TABLE AT RIGHT)  
 42 + 1-9 RING COUNT  
 44 + 1-4 CALL WAITING TYPE (SEE TABLE AT RIGHT)  
 45 + 00-99 RING DETECT  
 46 + 0-1 BACK BEEP (BEEP = 1)  
 47 + 1-9 TALK TIME 1 TO 9 MINUTES  
 48 + 0-1 KEYPAD ON

51 + XXXX\* PROGRAM PASSWORD

61 + X\* CALL FORWARD TONE  
 62 + 1 CALL FORWARD WITH NOTIFICATION  
 62 + 0 CALL FORWARD WITHOUT NOTIFICATION  
 64 + XXXXXXXXXXXX CALL FORWARD NUMBER (UP TO 16 DIGITS)  
 65 + 0 CALL FORWARD ON/OFF

999\* EXIT REMOTE PROGRAMMING

CALL WAITING RING TYPE	
SHORT SHORT	1
SHORT LONG	2
LONG SHORT	3
LONG LONG	4



# Configuration Guide

(TELCO to House to SG-1 to House, with RJ31X at house side, is recommended.)

TYPICAL SINGLE RESIDENCE CONFIGURATION



SINGLE RESIDENCE WITH MULTI-LINE CONFIGURATION

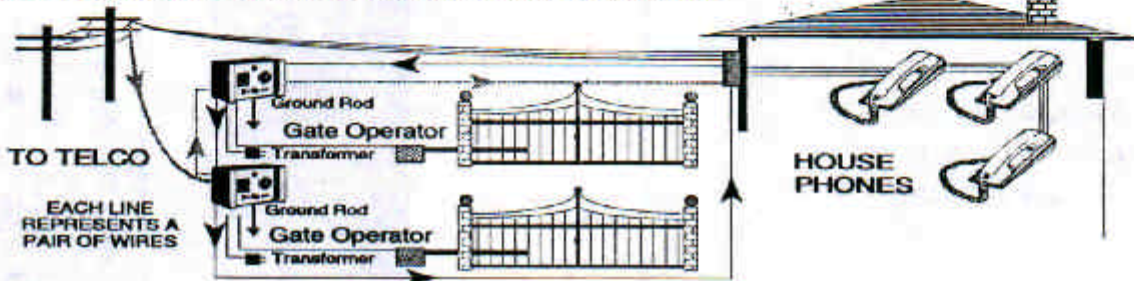

RESIDENCE WITH MULTI-LINE CONFIGURATION W/PBX  
SG-1 on its own TELCO line.

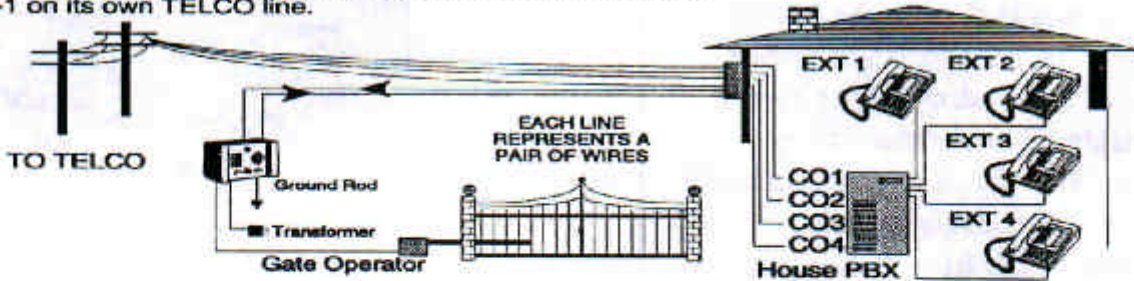

FACILITY WITH PBX  
SG-1 on a PBX extension.

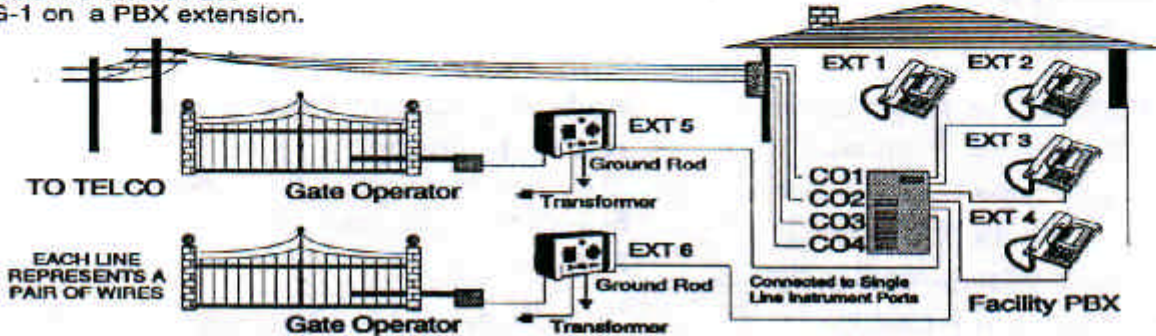

## I. FCC REQUIREMENTS

1. The Federal Communications Commission (FCC) has established Rules which permit this device to be directly connected to the telephone network. Standardized jacks are used for these connections. This equipment should not be used on party lines or coin lines.
2. If this unit is malfunctioning, it may also be causing harm to the telephone network; this device should be disconnected until the source of the problem can be determined and until repair has been made. If this is not done, the telephone company may temporarily disconnect service.
3. The telephone company may make changes in its technical operations and procedures; if such changes affect the compatibility or use of this device, the telephone company is required to give adequate notice of the changes. You will be advised of your right to file a complaint with the FCC.
4. If the telephone company requests information on what equipment is connected to their lines, inform them of:
  - a. The telephone number this unit is connected to
  - b. The ringer equivalence number
  - c. The USOC jack required
  - d. The FCC Registration number

Items `b' and `d' are indicated on the label.

The ringer equivalence (REN) is used to determine how many devices can be connected to your telephone line. In most areas, the sum of the RENs of all devices on any one line should not exceed five (5.0). If too many devices are attached, they may not ring properly.

## II. SERVICE REQUIREMENTS

1. In the event of equipment malfunction, all repairs should be performed by our Company or an authorized agent. It is the responsibility of users requiring service to report the need for service to our Company or to one of our authorized agents. Service can be obtained at:

---

---

---

Phone: \_\_\_\_\_

**Warning:** Changes or modifications not expressly approved by the party responsible for compliance could void the user's authority to operate the equipment.

**NOTE:** This Equipment has been tested and found to comply with the limits for a Class A digital device, pursuant to Part 15 of the FCC Rules. These limits provide a reasonable protection against harmful interference when the equipment is operated in a commercial environment. This equipment generates, uses and can radiate radio frequency energy and, if not installed and used in accordance with the instruction manual, may cause harmful interference to radio communications. Operation of this equipment in a residential area is likely to cause harmful interference in which case the user will be required to correct the interference at his own expense.

**NOTICE:** The Canadian Department of Communications label identifies certified equipment. This certification means that the equipment meets certain telecommunications network protective, operational and safety requirements. The Department does not guarantee the equipment will operate to the user's satisfaction.

Before installing this equipment, users should ensure that it is permissible to be connected to the facilities of the local telecommunications company. The equipment must also be installed using an acceptable method of connection. In some cases, the company's inside wiring associated with a single line individual service may be extended by means of a certified connector assembly (telephone extension cord). The customer should be aware that compliance with the above conditions may not prevent degradation of service in some situations.

Repairs to certified equipment should be made by an authorized Canadian maintenance facility designated by the supplier. Any repairs or alterations made by the user to this equipment, or equipment malfunctions, may give the telecommunications company cause to request the user to disconnect the equipment.

Users should ensure for their own protection that the electrical ground connections of the power utility, telephone lines and internal metallic water pipe system, if present, are connected together. This precaution may be particularly important in rural areas.

**Caution:** Users should not attempt to make such connections themselves, but should contact the appropriate electric inspection authority, or electrician, as appropriate.

The **Load Number** (LN) assigned to each terminal device denotes the percentage of the total load to be connected to a telephone loop which is used by the device, to prevent overloading. The termination on a loop may consist of any combination of devices subject only to the requirement that the total Load Numbers of all the devices does not exceed 100.

This digital apparatus does not exceed the Class A limits for radio noise emissions from digital apparatus set out in the Radio Interference Regulations of the Canadian Department of Communications.

Le present appareil numerique n'emet pas de bruits radioelectriques depassant les limites applicables aux appareils numeriques de la Class A prescrites dans le Reglement sur le brouillage radioelectrique edicte par le ministere des Communications du Canada.

This page intentionally blank.

This page intentionally blank.

This page intentionally blank.

***“BETTER TECHNOLOGY MAKES BETTER SYSTEMS”***

*Last Printing Date*

**02/02**



***Select  
Engineered  
Systems, Inc.  
7991 West 26th Ave.  
Hialeah, FL 33016  
Toll Free: 1-800-342-5737  
In FL: 305-823-5410  
Fax: 305-823-5215  
www.selectses.com***