

RADIOBAND TBX/RU INSTRUCTION MANUAL

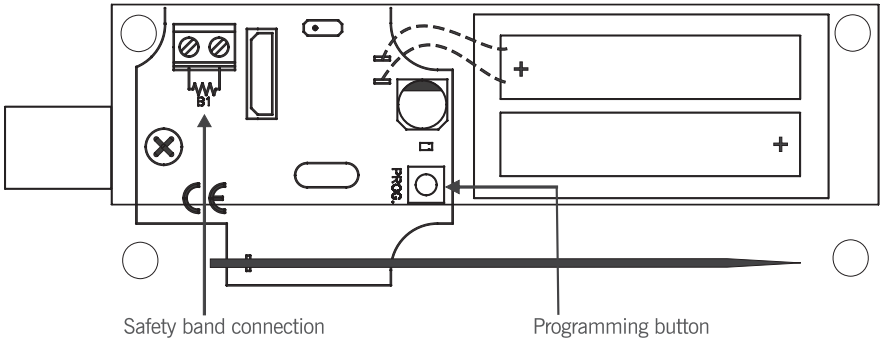

RADIOBAND/TBX



RADIOBAND/RU

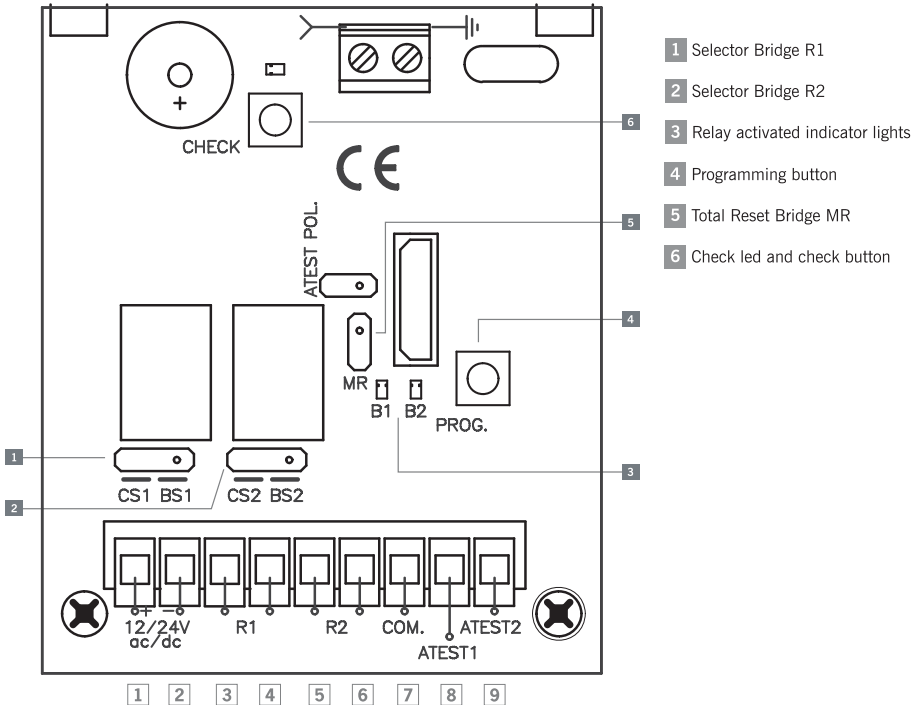

IMPORTANT: DO NOT PLACE METAL BETWEEN THE RECEIVER AND THE TRANSMITTER. IT WILL CAUSE R.F. INTERFERENCE ISSUES.

TECHNICAL FEATURES SAFETY EDGE RADIO TRANSMITTER

	RADIOBAND/TA	RADIOBAND/TBX
Operating frequency	868,90 MHz	
Power supply	3V DC (2 x 1,5V LR03 AAA)	3V DC (2 x 1.5V LR6 AA)
Op. consumption	12mA	
Radiated power	< 25mW	
Op. temperature	-20°C - +85°C	
Seal	IP67	
Dimensions	85x53x36mm	160x53x20mm
Range (guaranteed)	10 m	
Battery life	2 years	
Minimum time between two RADIOBAND/TA and/or RADIOBAND/TBX activations (for complying with the R&TTE Directive)	7 min.	

TECHNICAL FEATURES SAFETY EDGE RADIO RECEIVER

	RADIOBAND/RU	RADIOBAND/RC- RCS
Frequency	868,90 MHz	
Memory	6 RADIOBAND/TA and/or RADIOBAND/TBX (3 on relay 1, 3 on relay 2)	6 RADIOBAND/TA and/or RADIOBAND/TBX
Number of relays	2 relays	---
Power supply	12 / 24 Vac/dc	pluggable
Power supply range	9-35 V DC 8-28 V AC	---
Relay contacts	1 A	
Consumption: idle/op.	18mA / 80mA	18mA
Self-test input	2 0/12/24V AC/DC inputs with selectable polarity	incorporated
Radiated power	< 25 mW	
Op. temperature	-20°C to +85°C	
Seal	IP54 (with IP65 cable seals)	IP20
Box size	82x190x40mm	50x20x17mm
Range (guaranteed)	10 Mètres	
Minimum time between two ATEST activations (for complying with the R&TTE Directive)	7 min.	
Compliance with the Machinery Directive, according to EN-954-1 category 2		

INSTALLATION AND CONNECTIONS

RADIOBAND/TA, RADIOBAND/TBX: Fix the back of the box to the door. **Install the transmitter following the technical manual and avoid placing metallic surfaces between the receiver and the transmitter.** Pass the cables through the bottom of the transmitter. Connect a resistive 8K2 safety band directly to terminal B1 and ensure that the safety edge keeps totally waterproof. Fix the front of the transmitter to the back with the screws supplied for the purpose.

N.B.: If a non-resistive element (with a contact normally closed) needs to be connected, the jumper JP1 must be bridged. This application does not comply with safety standard EN 12453 for the use of motorised garage doors, since the connection of the resistive element to the RADIOBAND/TA and/or RADIOBAND/TBX is not checked.

RADIOBAND/RU: Fix the back of the box to the wall, using the wall plugs and screws supplied. **Install the receiver close to the door leaf and avoid metallic surfaces between the receiver and the transmitter.** Pass the cables through the bottom of the receiver. Connect the power cables to the terminals of the printed circuit, following the indications of the connections diagram. Store RADIOBAND/TA and/or RADIOBAND/TBX. Fix the front of the receiver to the back with the screws supplied for the purpose.

- 1- Power supply 12/24V AC/DC: (+)
- 2- Power supply 12/24V AC/DC (-)
- 3, 4- R1: Connect to the safety band input of the control panel (resistive contact 8.2kΩ) with jumper in position BS1 (see CONNECTIONS Figure 1). Or to the control panel safety contact input (NC) with jumper in position CS1 (see CONNECTION Figure 2).
- 5, 6- R2: Connect to a second safety band input of the control panel (resistive contact 8.2kΩ) with jumper in position BS2. Or to the control panel safety contact input (NC) with jumper in position CS2.
- 7- AUTOTEST: Common connection safety self-test (-). See CONNECTIONS Figure 3 and table POLARIZED SELFTEST.

- 8- AUTOTEST: Self-test connection for R1. See CONNECTIONS Figure 3 and table POLARIZED SELF-TEST.
 9- AUTOTEST: Self-test connection for R2. See CONNECTIONS Figure 3 and table POLARIZED SELF-TEST.

RADIOBAND/RC-RCS: Connection to a control panel using a connector for safety devices.

POLARIZED SELF-TEST

Check the self-test output on the control panel, in standby, to see whether the voltage is 0V (inverted test input) or 12/24V AC/DC (positive polarization). Switch on the self-test signal of the panel and check that it has a maximum duration of 3 seconds.

	Autotest output in standby	Autotest output activated	Polarization type	Jumper ATEST POL	ATEST1	ATEST2
Connection to a equipment with autotest	0V	12/24V	Positive	OFF	Connected*	Connected*
	12/24V	0V	inverted	ON	Connected*	Connected*
Connection to a equipment without autotest**	---	---	---	OFF	Not connected	Not connected

* Connect auto-test only for used outputs.

** Where the auto-test is not used, the system is not checked at the start of the operation, which means that security standard EN 12453 regarding the use of motorised garage doors is, in some cases, not complied with.

LIGHT INDICATORS

RADIOBAND/RU-RC-RCS	In operation	In programming
Relay 1 LED	Normally off. Indicates the status of the relay output. If R1 is not connected, on.	On. Indicates the channel to be programmed.
Relay 2 LED	Normally off. Indicates the status of the relay output. If R2 is not connected, on.	On. Indicates the channel to be programmed.

OPERATION

The receiver checks that all the programmed bands are working properly. If a band is activated or if there is an error in its operation, the receiver deactivates the output relay.

PROGRAMMING RADIOBAND/TA, RADIOBAND/TBX

If the receiver is in programming (see MANUAL PROGRAMMING below), press the transmitter button to programme it into the receiver

PROGRAMMING RADIOBAND/RU

MANUAL PROGRAMMING

RADIOBAND/RU makes it possible to store 6 RADIOBAND/TA and/or RADIOBAND/TBX (3 on Relay 1 and 3 on Relay 2).

Press the receiver programming PROG button for 1s; a sound signal will be heard. The receiver will go into programming the first relay. If the programming button is kept pressed, the receiver will go into programming the second relay, moving cyclically from one relay to another. Once the programming relay has been chosen for the transmitter you want to start using, send the programming code by pressing the transmitter. Every time a transmitter is programmed, the receiver will emit a sound signal for 0.5s. If 10 seconds pass without programming, the receiver will go out of programming mode, emitting two 1s sound signals. If, when programming a transmitter, the receiver's memory is full, it will emit 7 sound signals lasting 0.5s and come out of programming.

PROGRAMMING RADIOBAND/RC-RCS

MANUAL PROGRAMMING

RADIOBAND/RC-RCS makes it possible to store 6 RADIOBAND/TA and/or RADIOBAND/TBX (3 on Relay 1 and 3 on Relay 2).

Press the receiver programming PROG button for 1s; a sound signal will be heard. The receiver will enter safety band closing programming mode (BSC). If the programming button is kept pressed, the receiver will enter safety band opening programming mode (BSO), moving cyclically from one relay to another. Once the programming relay has been chosen for the transmitter you want to start using, send the programming code by pressing the transmitter. Every time a transmitter is programmed, the receiver will emit a sound signal for 0.5s. If 10 seconds pass without programming, the receiver will go out of programming mode, emitting two 1s sound signals. If, when programming a transmitter, the receiver's memory is full, it will emit 7 sound signals lasting 0.5s and come out of programming.

Note: For a right operation of the system, the transmitter has to be programmed in one receiver only.

RADIOBAND/TA, RADIOBAND/TBX replacement: In case you need to replace a RADIOBAND/TA or RADIOBAND/TBX, it is necessary to reset the system (see TOTAL RESET below) and reprogram all RADIOBAND/TA and/or RADIOBAND/TBX used in the installation.

SYSTEM CHECK

This function is used to check the functioning and range of all the devices once the installation has been carried out.

Press the receiver's CHECK for at least 1 second button to enter check mode. The indicator light will come on and four beeps will be heard.

Perform a complete door opening and closing maneuver. During the system check a beep will be heard every 1,5 seconds.

CORRECT FUNCTIONING OF THE SYSTEM

If no other acoustic signal is heard on completing the maneuver, the system is functioning correctly. Either press the CHECK button again or wait 5 minutes and the RADIOBAND/RU-RC-RCS will exit checking automatically, indicating with two beeps that the check has been correct. The check indicator light will go out .

DETECTION OF BAND FAILURE

If the communication with a RADIOBAND/TA or RADIOBAND/TBX fails during checking, or the communication is deficient (for instance, too many communication retries or poor coverage), the RADIOBAND/RU-RC-RCS emits three consecutive beeps, indicating that an error has occurred. Halt the door maneuver and press the safety bands installed to detect what has failed.

- If a single beep is heard on pressing a band, this means that the band is correct.

- If three consecutive beeps are heard on pressing the band, this means that the band has failed.

In this event, it is recommended changing the orientation of the transmitting-receiving aerials or installing an AED-868 or FLAT-868 outdoor aerial to ensure the desired range.

On exiting check mode, seven consecutive beeps will be heard and the indicator light will flash continuously.

Perform another system check until the result is correct.

Signal coverage

After pressing one of the installed bands, continuous flashes, ranging from 1 to 5, indicate the signal coverage for this band at the time it was pressed.

Number of check LED flashes	Coverage	Result of check
1	Very weak	Band failure
2	Weak	OK
3	Normal	OK
4	Good	OK
5	Very good	OK

TOTAL RESET

In programming mode, keep the programming PROG button pressed down and make a bridge with the "MR" reset jumper for 3s. The receiver will emit 10 warning sound signals and then more at a faster frequency, indicating that the operation has been carried out. The receiver will stay in programming mode.

If 10 seconds elapse without programming, or if you press the programming button quickly, the receiver will go out of programming mode, emitting two 1s sound signals.

TRANSMITTER BATTERY LOW INDICATOR (RADIOBAND/TA, RADIOBAND/TBX)

If the battery of a transmitter programmed into the receiver becomes low, it will give out 4 short signals every 20 seconds. If there is more than one transmitter programmed, the safety band must be activated to check whether the receiver then makes these 4 short signals. If this is the case, the transmitter connected to the activated safety band will be the one with the low battery. Change it.

CHANGING THE BATTERY

Remove the box cover. The batteries are positioned on the back of the cover. Replace the two used batteries with new ones, taking into account the polarity indicated by the connector. Check that the new batteries support the same temperature range as those they are replacing.

USE OF THE SYSTEM

These equipments are intended to be installed with a safety edge in garage doors installations. Their use is not guaranteed for directly activating equipment other than that specified.

The manufacturer reserves the right to change the specifications of the equipment without prior warning.

IMPORTANT APPENDIX

Disconnect the power supply before handling the equipment.

In accordance with the European low voltage directive, you are informed of the following requirements:

- For permanently connected equipment, an easily accessible connection device must be incorporated into the cabling.
- This equipment must be installed in a vertical position and firmly fixed to the structure of the building.
- This equipment may only be handled by a specialized installer, by maintenance staff or by a properly instructed operator.
- The instructions for use of this equipment must always remain in the possession of the user.
- Terminals with a maximum section of 3.8mm² must be used to connect the cables.
- The frequency of the Radioband system does not interfere in any way with the 868 MHz remote control systems. However a signal centred at 868,9MHz may cause a delay on the reaction of the system.

The keypad is approved by the FCC and it complies with Part 15 of the FCC Rules. Its operation is subject to the following 2 conditions:

1. This device may not cause harmful interference.
2. The device must accept any interference that may cause undesired operation.

WARNING:

Changes or modifications to this unit not expressly approved by the party responsible for compliance could void the user's authority to operate the equipment.

WARRANTY:

If, within two years from date of purchase, this product should become defective (except battery), due to faulty workmanship or materials, it will be repaired or replaced, without charge. Proof of purchase and a Return Authorization are required.

INSTALLATION ADVICE

Installation of the Radioband System on a one leaf sliding door with control panel and RADIOBAND/RU.

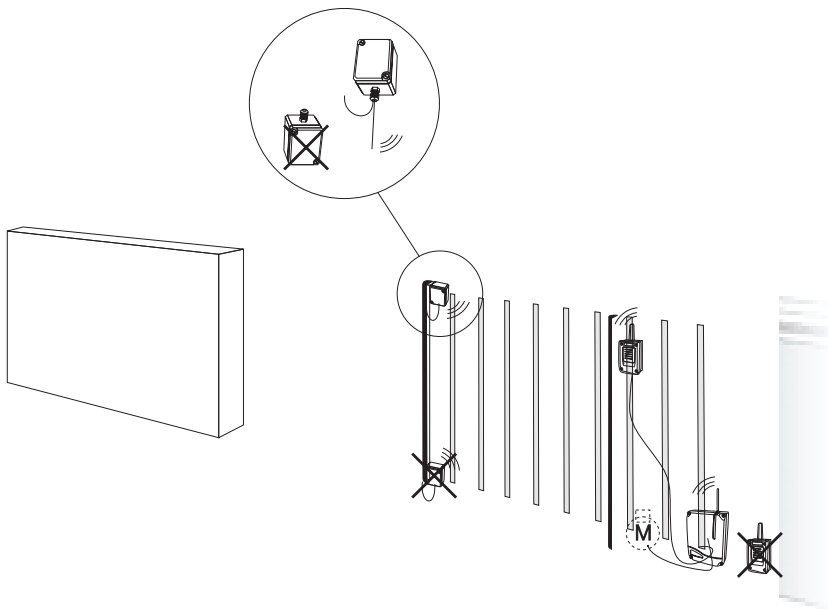

Installation of the Radioband System on an horizontal sectional door with control panel and RADIOBAND/RU.

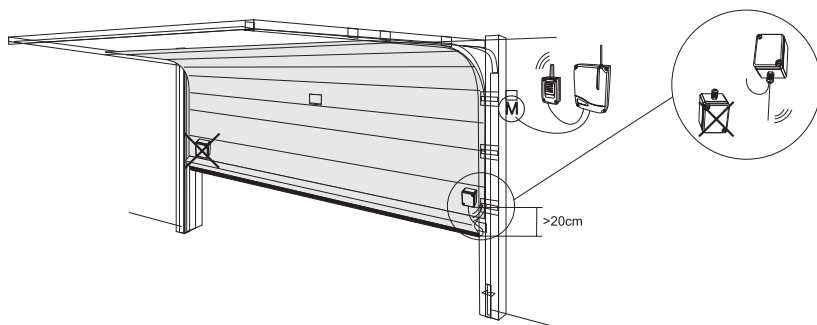



7380 S. Eastern Avenue, Suite 124-320 • Las Vegas, NV 89123
(866) 975-0101 * (866) 975-0404 Fax
www.transmittersolutions.com