

# The 750 Swing Gate Operator and 450 MPS Control Panel: Installation Manual

## Contents

Important Safety Information.....	2
Technical Data.....	4
The 750 Operator .....	4
The Control Panel .....	4
Unpacking the Operator .....	5
The 750 Swing Gate Operator.....	6
General Characteristics .....	6
Operating Logic .....	6
Manual Release Lever Mechanism .....	7
450 MPS Logic Modes .....	7
Installation Instructions.....	10
Preparing the Gate.....	10
Installing the 750 Operator.....	11
Set the Concrete Forms .....	11
Install the Power Unit .....	12
Install the Drive Unit.....	13
Connect the Hydraulic Lines.....	14
Synchronize the Hydraulic System.....	14
Install the Gate Leaf Shoe.....	14
Install the Gate Leaf.....	16
Installing the Control Panel.....	16
Connect the Main Power Supply .....	17
Connect One Activating Device.....	18
Connect the Operator(s) to the Control Panel .....	19
Adjust the Pressures for the Operator .....	19
Check the Motor's Direction of Rotation.....	21
Connect Other Devices .....	21
Set Other Operating Controls.....	24
Bleeding the Hydraulic System.....	25
Adjusting the Bypass Valves.....	25
Installing an Extension Arm.....	27
Maintenance .....	28
The 750 Operator .....	28
The Control Panel .....	28
Troubleshooting .....	28
Exploded View, 750 CBAC .....	31
Exploded View, 750 Ram Parts .....	32
750 Flex-Hose Adapter Kit .....	33

FAAC International, Inc.  
303 Lexington Avenue  
Cheyenne, WY 82007



# Important Safety Information

Both the installer and the owner and/or operator of this system need to read and understand this installation manual and the safety instructions supplied with other components of the gate system. This information should be retained by the owner and/or operator of the gate.

---

**WARNING!** To reduce the risk of injury or death

1. **READ AND FOLLOW ALL INSTRUCTIONS.**
2. Never let children operate or play with gate controls. Keep the remote control away from children.
3. Always keep people and objects away from the gate. **NO ONE SHOULD CROSS THE PATH OF THE MOVING GATE.**
4. Test the gate operator monthly. The gate **MUST** reverse on contact with a rigid object or stop when an object activates the non-contact sensors. After adjusting the force or the limit of travel, retest the gate operator. Failure to adjust and retest the gate operator properly can increase the risk of injury or death.
5. Use the emergency release only when the gate is not moving.
6. **KEEP GATES PROPERLY MAINTAINED.** Read the owner's manual. Have a qualified service person make repairs to gate hardware.
7. The entrance is for vehicles only. Pedestrians must use separate entrance.
8. **SAVE THESE INSTRUCTIONS.**

---

There are three kinds of safety issues involved with an automatic gate operator: issues arising from the design of the gate, from the installation of the gate and the operator, and from the use of the gate operator. The following information is designed to help you be sure

your gate and its operator are well-designed, installed correctly, and used safely.

## Gate Design

1. A gate is a potential traffic hazard, so it is important that you locate the gate far enough away from the road to eliminate the potential of traffic getting backed up. This distance is affected by the size of the gate, how often it is used, and how fast the gate operates.
2. The operator you choose to install on your gate must be designed for the type and size of your gate and for the frequency with which you use the operator.
3. Your gate must be properly installed and must work freely in both directions before the automatic operator is installed.
4. An automatic operator should be installed on the inside of the property/fence line. Do not install the operator on the public side of the property/fence line.
5. Pedestrians should not use a vehicular gate system. Prevent such inappropriate use by installing separate gates for pedestrians.
6. Exposed, reachable pinch points on a gate are potentially hazardous and must be eliminated or guarded.
7. Outward swinging gates with automatic operators should not open into a public area.
8. The operating controls for an automatic gate must be secured to prevent the unauthorized use of those controls.
9. The controls for an automatic gate should be located far enough from the gate so that a user cannot accidentally touch the gate when operating the controls.
10. An automatic gate operator should not be installed on a gate if people can reach or extend their arms or legs through the gate. Such gates should be guarded or screened to prevent such access.

## Installation

1. If you have any question about the safety of the gate operating system, do not install this operator. Consult the operator manufacturer.
2. The condition of the gate structure itself directly affects the reliability and safety of the gate operator.

3. Only qualified personnel should install this equipment. Failure to meet this requirement could cause severe injury and/or death, for which the manufacturer cannot be held responsible.
4. The installer must provide a main power switch that meets all applicable safety regulations.
5. Clearly indicate on the gate with a minimum of 2 warning signs (visible from either side of the gate) that indicate the following:
  - The gate is automatic and could move at any time, posing a serious risk of entrapment.
  - Children should not be allowed to operate the gate or play in the gate area.
  - The gate should be operated only when it is visible to the operator and the when the area is free of people and obstructions.
6. It is extremely unsafe to compensate for a damaged gate by overtightening a clutch or increasing hydraulic pressure.
7. Devices such as reversing edges and photocells must be installed to provide better protection for personal property and pedestrians. Install reversing devices that are appropriate to the gate design and gate application.
8. Before applying electrical power, be sure that the voltage requirements of the equipment correspond to your supply voltage. Refer to the label on your operator system.

#### Use

1. Use this equipment only in the capacity for which it was designed. Any use other than that stated should be considered improper and therefore dangerous.
2. When using any electrical equipment, observe some fundamental rules:
  - Do not touch the equipment with damp or humid hands or feet.
  - Do not install or operate the equipment with bare feet.
  - Do not allow small children or incapable persons to use the equipment.
3. If a gate system component malfunctions, turn off the main power before making any attempt to repair it.
4. Do not attempt to impede the movement of the gate. You may injure yourself as a result.
5. This equipment may reach high temperatures during operation; therefore, use caution when touching the external housing of the operator.
6. Learn to use the manual release mechanism according to the procedures found in this installation manual.
7. Before carrying out any cleaning or maintenance operations, disconnect the equipment from the electrical supply.
8. To guarantee the efficiency of this equipment, the manufacturer recommends that qualified personnel periodically check and maintain the equipment.

U.L. Class and FAAC Operator Model		Duty Cycle	Typical Use
<b>Class I: Residential Vehicular Gate Operator</b>			
402	750	Limited duty	• Home use
422	760		• Small apartment building, for example, up to 4 units in a building, with limited public access
412			
<b>Class II: Commercial/General Access Vehicular Gate Operator</b>			
400	640	Continuous duty	• Apartment buildings
620			• Very public access
<b>Class III: Industrial/Limited Access Vehicular Gate Operator</b>			
400	640	Continuous duty	• No public access
620			
<b>Class IV: Restricted Access Vehicular Gate Operator</b>			
620	640	Continuous duty	• Prison rated security

# Technical Data

## The 750 Operator

	750 Standard	750 Long Leaf	750 Extra Long Leaf
Ambient temperature, deg F (deg C)	-13 to 158 (-25 to 70)		
Maximum duty cycle, % motor run time	30		
Thermal cut out, deg F (deg C)	248 (120)		
Power voltage required, VAC*	115 ±10% or 230, +6 or -10%, 60 Hz	230, +6 or -10%, 60 Hz	
Absorbed power, W	220		
Motor speed, rpm	1400	960	
Type of oil	FAAC XD 220 or Shell/Tellus #15		
<b>Hydraulic Power Unit:</b>			
Height × width × depth, in. (cm)	13 <sup>3</sup> / <sub>4</sub> × 8 <sup>3</sup> / <sub>16</sub> × 5 <sup>1</sup> / <sub>8</sub> (35 × 20.8 × 13)		
Weight, lb (kg)	20 (9)		
Oil quantity, qt (l)	1 (0.9)		
Hydraulic locking:	CBC: Closed CBAC: Opened and closed	Not available	Not available
Gate weight, lb (kg)	1760 (800)		
Maximum gate length, ft (m)	7 (2.1)	10 (3)	13 (4)
<b>Hydraulic Drive Unit:</b>			
Height (not including shaft) × length × width, in. (cm)	4 <sup>7</sup> / <sub>8</sub> × 15 <sup>3</sup> / <sub>4</sub> × 7 <sup>7</sup> / <sub>8</sub> (12.4 × 40 × 20)		
Weight			
100-deg swing, lb (kg)	18 (8)		
180-deg swing, lb (kg)	20 (9)		
Oil quantity, qt (l)	0.9 (1)		
Maximum angle of rotation			
100-deg swing, deg	118		
180-deg swing, deg	200		
90-deg opening time, sec	12	17	
Nominal torque, ft-lb (Nm)	338 (460)		

\* Your standard 220 VAC power source meets the specification for 230 VAC, +6 or -10%.

## The Control Panel

A control panel must be installed with a 750 Operator. The 450 MPS control panel is available in a 220 VAC version and a 115 VAC version. The control panel allows you to set the following: the opening/closing time, pause time, delay of the second gate leaf in a two-leaf gate system, operating logic, reversing stroke, and behavior of reversing devices.

The voltage of your control panel must match the voltage required by your operator. Refer to the label on the power unit of the 750 Operator to see what the operator requires. To determine what your panel requires, refer to the label on the transformer of the control panel:

**Power source:** 220 or 115 VAC (60 Hz)  
**Operating logic:** A, S, E, EP, B, and C

# Unpacking the Operator

When you receive your 750 Operator, complete the following steps.

Inspect the shipping box for physical damage such as leaking oil or a torn carton. Then inspect the operator after you remove it from the box. Notify the carrier immediately if you note any damage because the carrier must witness the damage before you can file a claim.

As you unpack the boxes, insure that all the parts listed below are included.

## Control Panel:

- 1 Box with printed circuit board; screws or standoffs for attaching board to box included

## Power Unit (see Figure 1):

- 1 vinyl box with key (the power unit is shipped separately from the box)

(a)

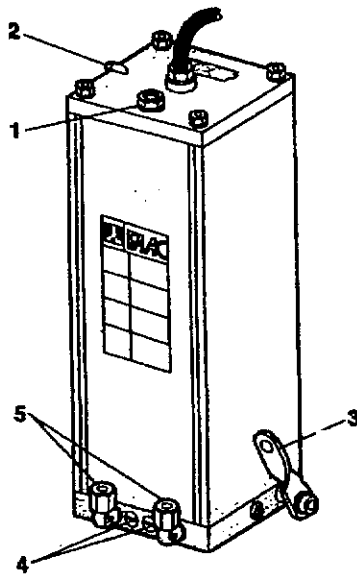

(b)

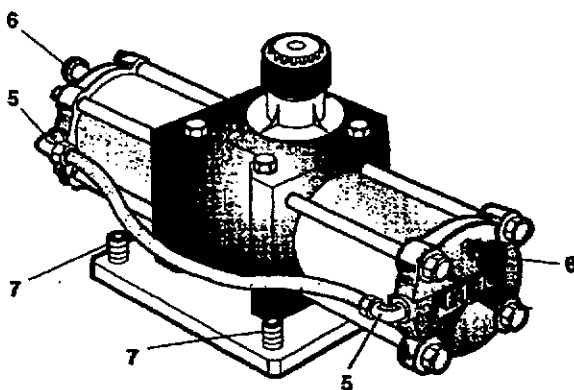

## Drive Unit (see Figure 1):

- 1 Hydraulic drive attached to its base plate with 4 leveling bolts installed and with the sleeve fitted over the splined shaft
- 2 "Box halves" (right-angled and lipped pieces of galvanized steel that together form the sides of the box around the drive unit)
- 1 Top cover protected by peel-off plastic
- 1 Package containing 2 mounting C brackets, 6 screws to hold cover on the drive unit, 4 ring fittings for hydraulic lines, 1 plastic half-sleeve to fit around drive shaft and match top cover, one 0.3-qt ( $\frac{1}{4}$  liter) container of hydraulic fluid
- 1 Plastic collar around splined shaft

- 1 Oil plug
- 2 Vent screw
- 3 Manual Release lever
- 4 By-pass valve screws
- 5 Hydraulic 90-deg elbow couplings
- 6 Bleed screws
- 7 Leveling bolts

Figure 1. Parts of the 750 (a) the power unit and (b) the drive unit (sometimes referred to as the ram unit)

# The 750 Swing Gate Operator

## General Characteristics

The 750 Operator with *GentleSwing*<sup>™</sup> Motion Management is a U.L. listed, medium-duty operator designed to swing a gate leaf from an unobtrusive in-ground installation, thus preserving the aesthetic appearance of the gate. A 750 Operator system consists of a hydraulic power unit, a hydraulic drive unit, and a control panel. The 750 Operator requires fixed positive limit stops for the gate leaf in the fully opened and closed positions.

Two models of the 750 Operator drive unit are available. One model is designed for swinging gates up to 100 degrees; the other model is designed for swinging gates up to 180 degrees. Either model has a 90-deg opening time of 12 to 17 sec.

The three models of the 750 Operator power unit (the Standard, Longer Leaf, and Extra Long Leaf) are designed for different gate configurations and offer different hydraulic locking. For all models of the power unit the axis of rotation for the gate leaf must fall along an imaginary plumb line that is at least 2<sup>3</sup>/<sub>8</sub> in. (6 cm) out from the gate side of the pillar.

The Standard power unit is designed for a gate leaf of no more than 7 ft and 1760 lb and offers hydraulic locking in the opened and closed positions.

The hydraulic locking that the Standard power unit provides is a service feature that helps to keep a gate fully closed. However, we recommend external locking mechanisms for any one of the following situations:

- Your gate leaf is 7 ft (2.1 m) or longer.
- Your installation site requires tight security.
- Your gate site is subject to vandalism.
- Your gate site is subject to strong or very gusty wind.
- Your gate design includes a firebox for emergency entry/exit.

The Longer Leaf and Extra Long Leaf power units are designed for a gate leaf of no more than 10 and 13 ft, respectively, and 1760 lb. In addition, neither the Longer Leaf nor the Extra Long Leaf power unit offers hydraulic locking, so an external lock is recommended.

For gates with two leaves, an operator (a drive unit and a power unit) is installed for each leaf. We recommend in such two-leaf installations that both drive units be the same model and that both power units be the same model. The single control panel that operates the two 750 Operators can be programmed to swing one gate leaf slightly later than the other to allow for overlapping leaves.

The electronic control panel is a microprocessor-based controller that accepts a range of product accessories and reversing devices to allow flexibility in designing the gate system. The control panel allows you to set the following:

- Opening/closing time
- Pause time
- Delay of the second gate leaf in a two-leaf gate system
- Operating logic
- Reversing stroke
- Behavior of reversing devices

The 750 Operator includes two bypass valves that control the thrust of the gate leaves. A Manual Release lever mechanism disengages the hydraulic system and allows you to operate the gate by hand. Swinging the gate open or closed by hand is necessary during installation and useful during power failures.

The two bypass valves located on the hydraulic power unit can be adjusted to vary the force of the gate as it opens or closes. FAAC recommends that the gate should stop its movement if it encounters a force of more than about 33 lb (15 kg). The installer of the 750 Operator makes the necessary adjustments.

**Note:** The condition of the gate structure itself directly affects the reliability and safety of the gate operator.

Additional reversing devices such as inductive loops or photocells should be installed to provide non-contact reversing operation.

## Operating Logic

The 750 Operator provides a Manual Release lever mechanism for manually operating the gate and

provides six operating modes, detailed on pages 8 and 9.

## Manual Release Lever Mechanism

The Manual Release lever mechanism is a built-in release device of the 750 Operator (see Figure 1). You disengage the hydraulic operation of the operator by rotating the Manual Release lever toward you and down. Then you can move the gate by hand to open or close the gate. Operating the gate by hand is necessary during installation and is useful during power failures.

To re-engage the hydraulic operation of the operator, rotate the Manual Release lever up and away from you for normal gate operation.

## 450 MPS Logic Modes

**Note:** Reversing devices are either opening reversing devices or closing reversing devices, depending on where the device is connected on the terminal strip. FAAC strongly recommends the use of reversing devices no matter which logic you choose for your gate operation.

The logics available on the 450 MPS control panel are briefly described below. You can find a complete description of each logic in the tables on pages 8 and 9.

- **A (automatic):** The gate opens on command and automatically closes after a pause phase. A second command on opening is ignored; a second command during pause phase causes the gate to close immediately; a second command during closing reopens the gate.
- **S (security):** The automatic mode is like A logic except that a second command during opening immediately closes both gate leaves.
- **E (semi-automatic):** This mode requires a command to open and a command to close. A second command during opening or closing causes the gate leaves to stop all motion. A third command then closes the gate.
- **EP (semi-automatic, step by step):** This mode requires a command to open and a command to close. A second command during opening or closing causes the gate leaves to stop all motion. A third command then reverses the previous motion of the gate leaves.
- **B (manned, pulsed):** This mode is designed for guard station use and requires a three-button switch (pulsed) to open, close, and stop the gate.
- **C (manned and constant):** This mode is designed for guard station use and requires at least a two-button switch (constant pressure required on each button) to open, close, and stop the gate (no pressure on a button stops the gate).

### A (Automatic) Logic

Gate Status	Open A	Open B	Stop	Opening Reversing Device(s)	Closing Reversing Device(s)	Warning Light
Closed	Opens both leaves and closes them after pause time	Opens single leaf connected to Motor 1 and closes it after pause time	No effect	No effect	No effect	Off
Opening	No effect	No effect	Stops	Stops; gate closes when reversing device no longer triggered	No effect	On
Opened	Closes both leaves immediately	Closes leaf immediately	Stops	No effect	Gate remains open until reversing devices no longer triggered	On
Closing	Opens both leaves immediately	Opens leaf immediately	Stops	No effect	Depends on DIP switch 4	Flashes
Stopped	Closes the leaves	Closes the leaf	No effect (opening is inhibited)	No effect	No effect (opening is inhibited)	On

### S (Security) Logic

Gate Status	Open A	Open B	Stop	Opening Reversing Device(s)	Closing Reversing Device(s)	Warning Light
Closed	Opens both leaves and closes them after pause time	Opens single leaf connected to Motor 1 and closes it after pause time	No effect	No effect	No effect	Off
Opening	Closes both leaves immediately	Closes the leaf immediately	Stops	Stops; gate closes when reversing device no longer triggered	No effect	On
Opened	Closes both leaves immediately	Closes leaf immediately	Stops	No effect	Gate remains open until reversing devices no longer triggered	On
Closing	Opens both leaves immediately	Opens leaf immediately	Stops	No effect	Depends on DIP switch 4	Flashes
Stopped	Closes the leaves	Closes the leaf	No effect (opening is inhibited)	No effect	No effect (opening is inhibited)	On

### B (Manned, Pulsed) Logic

Gate Status	Open A	Open B	Stop	Opening Reversing Device(s)	Closing Reversing Device(s)	Warning Light
Closed	Opens 1 or both leaves	No effect	No effect	No effect	No effect	Off
Opening	No effect	No effect	Stops	No effect	Stops	On
Opened	No effect	Closes 1 or both leaves	No effect	No effect	No effect	On
Closing	No effect	No effect	Stops	Stops	No effect	Flashes
Stopped	Opens 1 or both leaves	Closes 1 or both leaves	No effect	No effect	No effect	On



### E (Semi-automatic) Logic

Gate Status	Open A	Open B	Stop	Opening Reversing Device(s)	Closing Reversing Device(s)	Warning Light
<b>Closed</b>	Opens both leaves	Opens single leaf connected to Motor 1	No effect	No effect	No effect	Off
<b>Opening</b>	Stops	Stops	Stops	Stops; gate closes when reversing device no longer triggered	No effect	On
<b>Opened</b>	Closes both leaves immediately	Closes leaf immediately	Stops	No effect	No effect (opening is inhibited)	On
<b>Closings</b>	Stops	Stops	Stops	No effect (opening is inhibited)	Depends on DIP switch 4	Flashes
<b>Stopped</b>	Closes the leaves	Closes the leaf	No effect (opening is inhibited)	No effect	No effect (opening is inhibited)	On

### EP (Semi-automatic, Step by Step) Logic

Gate Status	Open A	Open B	Stop	Opening Reversing Device(s)	Closing Reversing Device(s)	Warning Light
<b>Closed</b>	Opens both leaves	Opens single leaf connected to Motor 1	No effect (opening is inhibited)	No effect (opening is inhibited)	No effect (opening is inhibited)	Off
<b>Opening</b>	Stops	Stops	Stops	Stops; gate closes when reversing device no longer triggered	No effect	On
<b>Opened</b>	Closes both leaves immediately	Closes leaf immediately	Stops	No effect	No effect (opening is inhibited)	On
<b>Closing</b>	Stops	Stops	Stops	No effect (opening is inhibited)	Depends on DIP switch 4	Flashes
<b>Stopped</b>	Gate leaves reverse direction	Gate leaf reverses direction	No effect (opening is inhibited)	No effect (opening is inhibited)	No effect (opening is inhibited)	On

### C (Manned and Constant) Logic

Gate Status	Open A	Open B	Stop	Opening Reversing Device(s)	Closing Reversing Device(s)	Warning Light
<b>Closed</b>	Opens 1 or both leaves	No effect	No effect	No effect	No effect	Off
<b>Opening</b>	No effect	No effect	Stops	No effect	Stops	On
<b>Opened</b>	No effect	Closes 1 or both leaves	No effect	No effect	No effect	On
<b>Closing</b>	No effect	No effect	Stops	Stops	No effect	Flashes
<b>Stopped</b>	Opens 1 or both leaves	Closes 1 or both leaves	No effect	No effect	No effect	On

# Installation Instructions

**Note:** The following installation instructions assume you are fully capable of installing an electronic/hydraulic operator for a gate. This manual does not instruct you in designing a gate, installing a gate (whether on masonry, wood, or metal posts), or basic electrical wiring. The installation tasks discussed in this manual are tasks peculiar to the 750 Operator.

## Preparing the Gate

Before you install the 750 Operator, you must insure that the gate leaf meets the following criteria.

1. The gate leaf must not exceed the weight and length constraints for the power unit you are installing (see page 3). If you are retrofitting the 750 Operator to an existing gate, you need to remove the bottom-most hinge if it interferes with the installation and insure that the axis of rotation through the remaining hinge(s) is perfectly plumb.

2. The geometry of the gate must meet the two constraints shown in Figure 2 and explained below:

(a) The bottom of the gate leaf on the side nearest the gate post must form a 90-deg corner (see note below).

(b) The distance between the gate post and the center of the gate hinge must be at least  $2\frac{3}{8}$  in. (6 cm).

3. Make sure the gate leaf has positive limit stops in both the opening and closing directions (see Figure 3).

**Note:** If you are installing the 750 Operator with an extension arm, some of the constraints about the gate leaf do not apply to your gate leaf. See the section "Installing an Extension Arm" for more information on page 26.

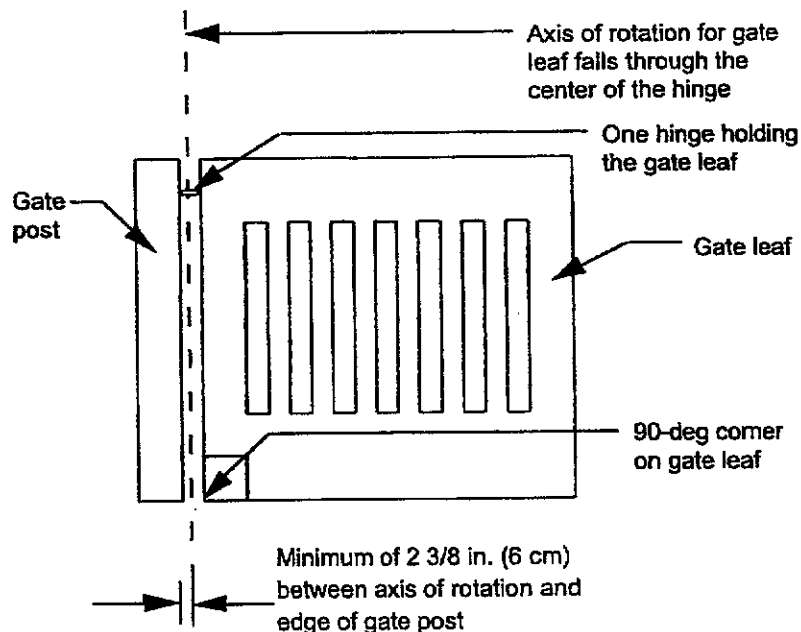

**Note:** If your gate does not meet the constraints, you may want to install an extension arm  
**Figure 2. Constraints on the geometry of the gate leaf**

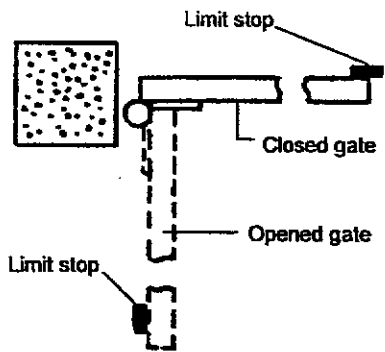

Figure 3. Limit stops

## Installing the 750 Operator

Installing the 750 Operator consists of the following steps:

- Setting the concrete forms
- Installing the power unit
- Installing the drive unit
- Connecting the hydraulic lines
- Synchronizing the hydraulic system
- Installing the gate leaf shoe
- Installing the gate leaf
- Installing the control panel
- Adjusting the hydraulic pressures for the operator

- Checking the motor rotation
- Bleeding the hydraulic system
- Adjusting the bypass valves

## Set the Concrete Forms

You need to lay out the concrete forms according to the dimensions shown in Figures 4 and 5. (Your soil conditions may also determine the size of the cement footing.)

**Note:** If the vertical distance between the finished grade and the bottom of the gate leaf exceeds 1 1/4 in. (3.3 cm) as shown in Figure 5, you can install a shear-pin assembly as shown in Figure 9 and as discussed in "Installing the Gate Leaf Shoe."

Accurately positioning the foundation plate beneath the gate hinge is critical especially if it supports the drive unit, which supports the gate leaf.

**Note:** The foundation plate may be supplied by the installer. If so, it must meet the specifications shown in Figure 4.

**Note:** Insure that the cavity where the drive unit is located is well drained by means of pipes, gravel drainage, or both, whatever is appropriate for your soil conditions.

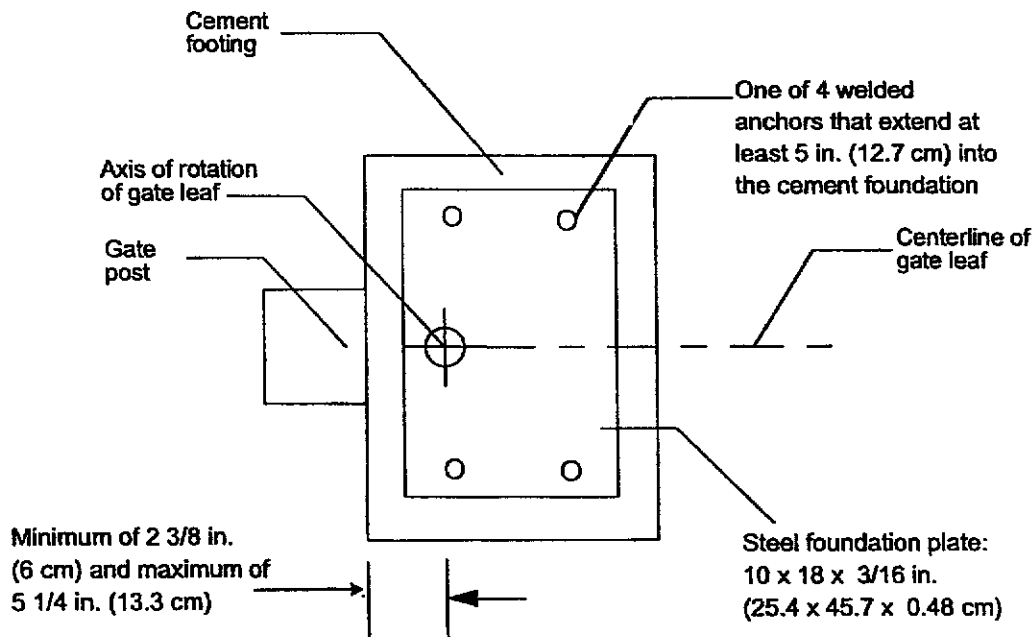
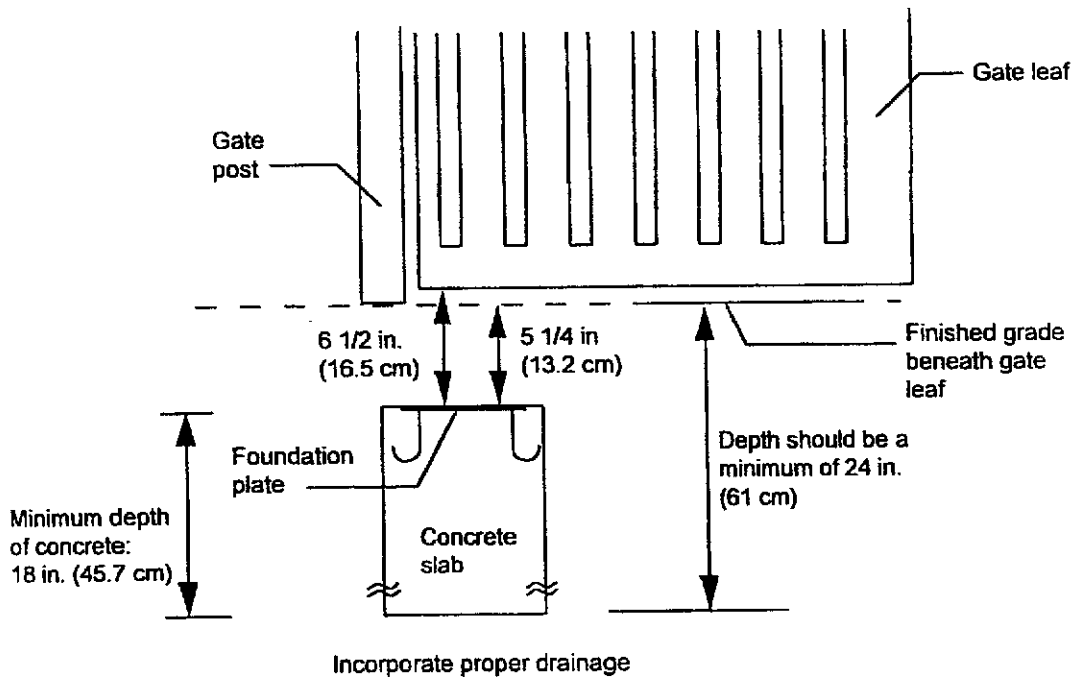

Figure 4. Recommended dimensions for the concrete footing and foundation plate, top view



**Figure 5. Recommended dimensions for the concrete footing and foundation plate, side view**

After the concrete is poured in the form and before it has a chance to set, insert the foundation plate into the cement and position it so that it is flush with the top of the concrete and is level.

Allow the concrete to set a minimum of two full days before you install the drive unit on top of it.

## Install the Power Unit

Figure 6 shows important dimensions and parts of the vinyl power unit box.

There are two constraints to installing the power unit box for the 750 Operator.

1. We recommend that you install the power unit box so that the hydraulic lines between it and the drive unit are no longer than 20 ft (6 m).
2. The power unit itself must be installed so that the vent screw is on the top of the unit as shown in Figure 6.

The power unit box that ships with your operator hinges on the left, but you can reverse the opening direction of the door if necessary for your installation. To reverse the opening direction, open the cover, and then lift it off the box. The vinyl hinges can now be placed in the

hinge receptacles on the right-hand side. Secure the hinges with the screws provided.

You may surface mount the power unit box to a vertical surface or you may recess it.

To mount the power unit box use the 3/16-in. holes provided (relocating the holes in the box will compromise its integrity).

If you recess the box, keep in mind that hydraulic hoses and electrical wiring need to enter the bottom of the box.

Also, recessing must not interfere with the hinge assembly of the power unit box. You need to keep in mind the following dimensions.

Height: 14 1/4 in. (36.2 cm)

Width: 10 in. (25.5 cm)

Depth: *maximum* of 2 1/2 in. (6.5 cm)

At this time, you also need to remove the vent screw located on the power unit. The vent screw is in the middle of the top, left side of the power unit as shown in Figure 6.

**Caution:** Failure to remove the vent screw in the power unit may result in erratic operation of the 750 Operator.

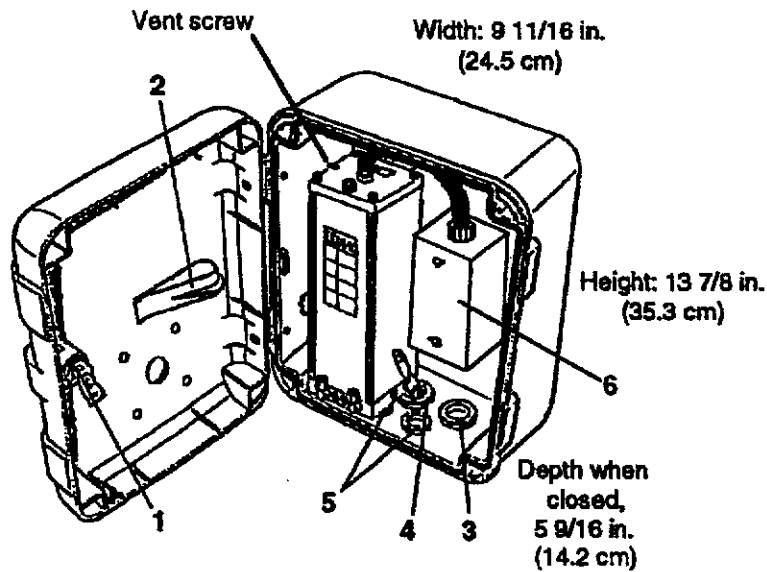

- 1 Lock for triangular key
- 2 Clip to hold instruction manual
- 3 1 1/16 in. (3 cm) holes for hydraulic lines
- 4 1 1/16 in. (3 cm) knock-outs
- 5 Three knock-outs, each measuring 3/4 in. (2 cm)
- 6 Electrical junction box

Figure 6. Parts of the power unit in the vinyl box

## Install the Drive Unit

To install the drive unit, first make sure the four leveling bolts on the base of the unit do not protrude from the bottom of the unit. Then place the unit on the foundation plate (see Figure 7).

Position the drive unit according to the following:

1. The side of the drive unit with the splined shaft should be the side nearest the gate post.
2. The longitudinal axis of the drive unit is perpendicular to (at right angles to) the fully closed gate leaf.

3. The center of the splined shaft is vertically aligned with the center of the gate hinge axis (use a plumb line).

**Caution:** *NEVER* weld the base plate of the drive unit to the foundation plate. Weld only the mounting C brackets to the foundation plate.

When the position of the drive unit meets these conditions, weld the C-shaped mounting brackets to the foundation plate to hold the drive unit in position (see Figure 7).

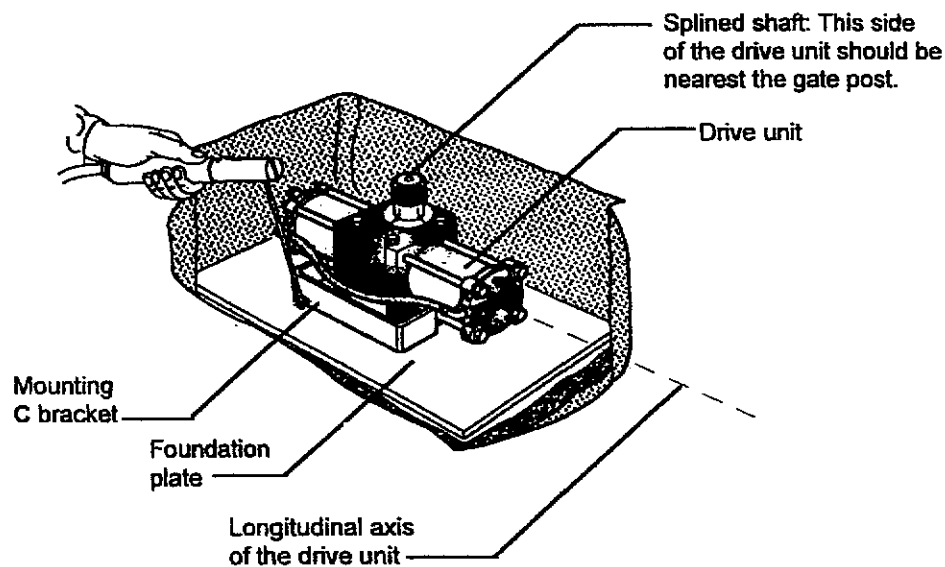

Figure 7. Welding the mounting C bracket to the foundation plate

Next you need to prepare the two L-shaped "box halves" for installation. Note that the lip on each piece should be on top so as to support the top cover. Make the necessary holes for the two hydraulic lines that run from the drive unit to the power unit.

Once you have made your access holes, you can weld the box halves to the foundation plate and to one another so as to enclose the drive unit on four sides. Be sure to protect the drive unit during welding.

## Connect the Hydraulic Lines

**Caution:** It is important that the hydraulic lines be kept clean of any debris.

The drive unit and power unit are connected by two hydraulic lines, each with an outside diameter of 5/16 in. (0.8 cm), an inside diameter of 5/32 in. (0.4 cm), and a 2,500 psi (170 bar) rating.

**Caution:** After removing the nylon piping, do not rotate the splined shaft while you are connecting the hydraulic lines to avoid squirting hydraulic fluid.

Remove the nylon piping connecting the two hydraulic pipe fittings on the drive unit. Clean up any spilled hydraulic fluid.

Be sure the hydraulic lines are free of any debris by flushing them with a jet of compressed air. Then attach one line to each fitting on the drive unit.

Next you attach the other end of the hydraulic lines to the pipe fittings on the power unit (see Figure 8; additional information can be found in the technical drawing on page 29). Attaching the correct line to the correct fitting is important. Make sure that the hose on the end of the drive unit that is on the closing side of the gate/fence line attaches to the hydraulic pipe fitting in the power unit that is nearest the green bypass valve screw. This connection insures that the green valve controls opening pressure.

**Caution:** Do *not* remove and do *not* tighten the elbow-shaped pipe fittings on the power unit. They have been locked into position with a thread locker to help seal the hydraulic system.

## Synchronize the Hydraulic System

Next you need to disengage the hydraulic system in order to synchronize it.

Inside the power unit is the Manual Release lever that disengages the hydraulic system (see Figure 1). Make

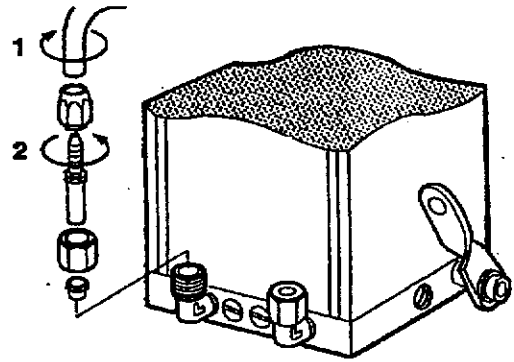

**Figure 8.** Connect the hydraulic line to the power unit. See the technical drawing on the next to last page for more information.

sure the Manual Release lever is turned toward you and down to disengage the hydraulic system.

Now you can synchronize (set) the hydraulic system to the closed position by turning the splined shaft in the closing direction. Turn the shaft as far as it will go. To prevent the piston in the drive unit from bottoming in its cylinder, next turn the splined shaft about 5 deg in the opening direction.

The position of the shaft now corresponds to the fully closed position of the gate leaf. The hydraulic system is now synchronized (set).

**Caution:** The splined shaft must not be moved from its closed position until the gate leaf shoe that holds the gate leaf has been attached.

## Install the Gate Leaf Shoe

If the vertical distance between the finished grade under the gate and the bottom of the gate leaf is more than 1 1/4 in. (see Figure 5), you need to do one of the following:

- Install a length of appropriately sized pipe between the sleeve that fits around the splined shaft of the operator and the gate leaf shoe.
- Construct a shear-pin assembly to accommodate the extra vertical distance. The assembly is welded to the bottom of the gate leaf shoe on one end and to the sleeve for the splined shaft of the pinion on the other end (see Figures 9 and 10). Such an assembly requires a bottom hinge and also protects the pinion and splined shaft in the event something hits the gate with great force.

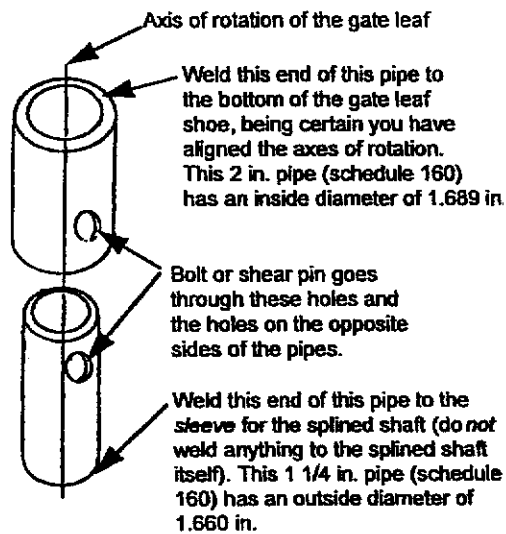

Figure 9. A sample shear-pin assembly

Installing the gate leaf shoe involves making the gate leaf shoe, positioning it, and welding it to the splined shaft sleeve. If you are retrofitting the 750 Operator to an existing gate, these tasks require you to remove the gate leaf from its hinges. If you are using a shear-pin assembly, refer to Figures 9 and 10 to determine what you should weld together.

The gate leaf shoe is designed to carry the weight of the gate leaf and transfer the weight to the splined shaft. The shoe surrounds the 90-deg gate-post corner of the gate leaf to carry the gate and to act as a lower hinge. The shoe is made of a U-shaped section and a vertical

section (see Figure 10). Later you will weld the bottom of the U-shaped section to the sleeve for the splined shaft (or to the shear-pin assembly, which is welded to the sleeve).

Since the gate leaf shoe holds the gate leaf, both sections must be made of steel at least 1/4 in. (0.6 cm) thick. The U-shaped section of the shoe must be a minimum of 5 3/4 in. (2.1 cm) long and must be as wide as the gate leaf is thick and must fit as tightly as possible to minimize leaf movement within the shoe (see Figure 11).

Construct the U-shaped section of the shoe and verify that it fits around the gate leaf. Position the U-shaped section over the splined shaft so that the leaf's axis of rotation will fall within the minimum dimensions shown in Figure 11.

On the U-shaped section of the shoe, mark the position for the leaf's axis of rotation. Next, drill a pilot hole in the U-shaped section to mark the axis of rotation point and mark the position for the placement of the vertical section of the shoe.

Next you need to position the sleeve for the splined shaft of the pinion (or the shear-pin assembly) on the bottom side of the U-shaped section of the shoe as shown in Figure 10. On the bottom of the U-shaped shoe section, center the sleeve around the pilot hole that marks the axis of rotation. Accurately centering the pilot hole is important.

**Caution:** NEVER weld the splined shaft to anything.

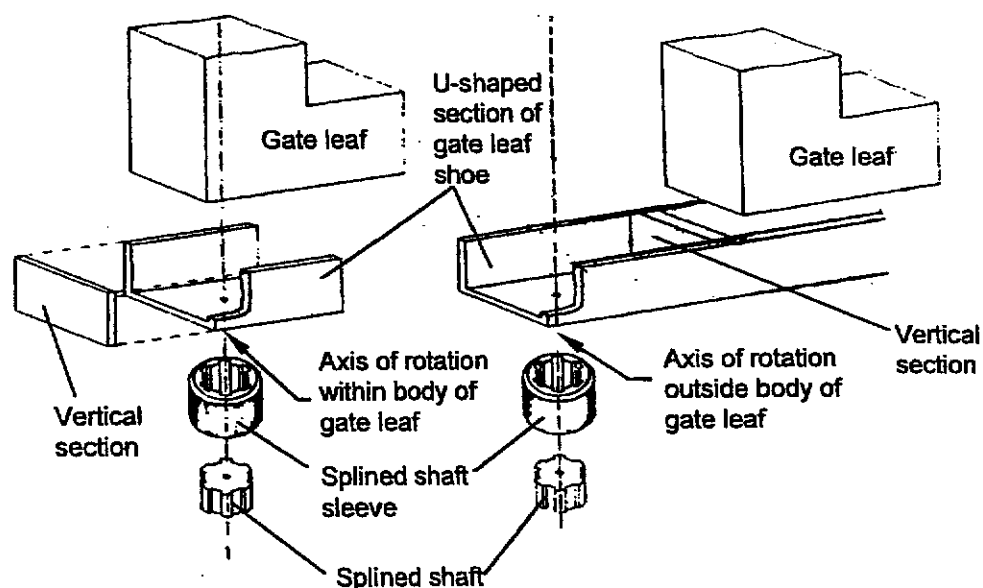

Note: The gate's axis of rotation may fall within or outside the body of the gate leaf.

Figure 10. Parts of the gate leaf shoe

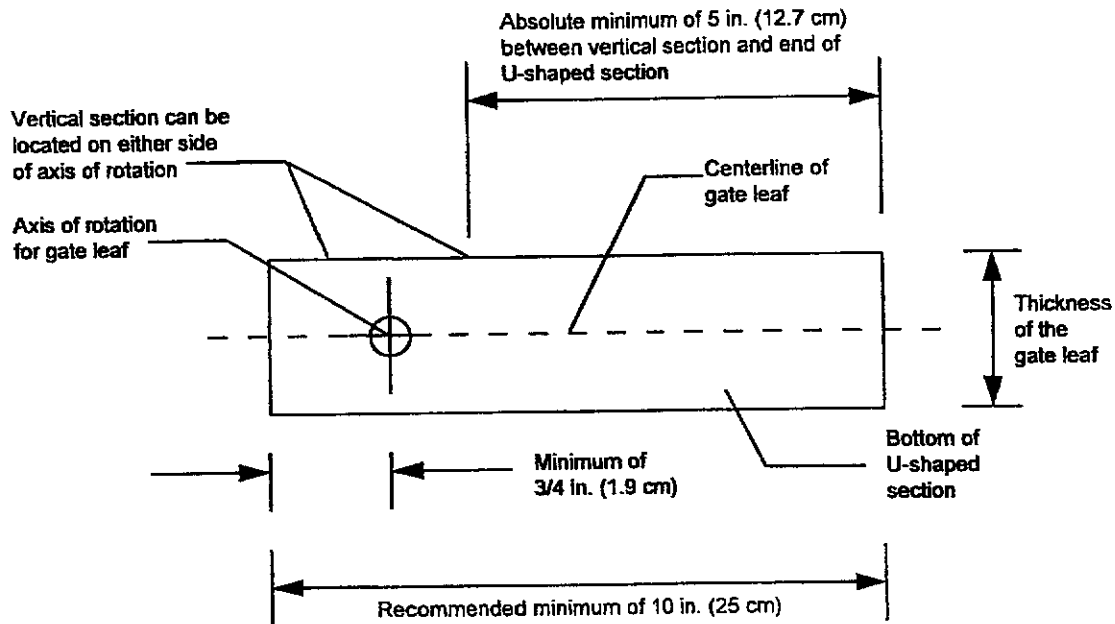

**Figure 11. Top view of the U-shaped section of the gate leaf shoe**

Spot-weld the sleeve into place on the bottom of the shoe's U-shaped section. If you are using the shear-pin assembly, spot weld the sleeve to the bottom of the shear-pin assembly, and spot weld the top of the shear-pin assembly to the bottom of the shoe's U-shaped section.

Next you must test the temporarily welded position of the splined shaft's sleeve. Fit the shaft sleeve over the splined shaft with the U-shaped section aligned in the gate leaf's fully closed position. Verify with a plumb line that the axis of rotation falls through the pilot hole to the center of the splined shaft.

If the axis of rotation alignments are correct, then permanently weld the sleeve for the splined shaft to the bottom of the U-shaped section of the shoe.

Also, you now need to weld the pilot hole closed, and you need to weld the vertical section of the shoe to the U-shaped section of the shoe.

Lubricate the splined shaft with grease and place the finished gate leaf shoe over the shaft in the closed position.

## Install the Gate Leaf

If you are not using the telescoping shear-pin assembly, install the gate leaf by placing its 90-deg corner into the gate leaf shoe and then installing the top gate hinge.

Installing the top gate hinge may require the gate leaf to be at a particular height. To raise (or lower) the gate leaf to the proper height, equally adjust the four leveling bolts on the base of the drive unit. The bolts raise (or

lower) the splined shaft and thus the gate leaf shoe and gate leaf.

To test the installation of the gate leaf, first make sure that the hydraulic system has been disengaged (the Manual Release lever should point down).

Next, very slowly open and close the gate leaf a few times to see if it moves smoothly and evenly through its entire path. As necessary, adjust the leveling bolts on the base of the drive unit to correct any problems with the gate's travel.

## Installing the Control Panel

Locate the control panel in the most convenient position possible, considering the movement of the gate. For example, a good position for the control panel box is on the inner face of the post or pillar. Figure 12 shows the typical layout for a two-leaf gate with the 750 Operator.

If you are embedding the control panel box into a wall or post, you must be sure to allow a clearance between the surface of the wall or post and the rim under the lid of the control panel box.

Installing the control panel consists of six general steps:

- Connecting the main power to the control panel
- Connecting the activating device
- Connecting the operator to the control panel
- Checking the direction of the motor's rotation



- Connecting other devices (activating and reversing) to the control panel
- Setting DIP switches and potentiometers for normal operation

The installer is responsible for grounding the gate and operator systems, for providing the main power breaker switch, and for making sure that the entire gate system meets all applicable electrical codes.

The installer is responsible for grounding the operator systems, for providing the main power breaker switch, and for making sure that the entire gate system meets all applicable electrical codes.

Follow the instructions below when installing the control panel for the 750 Operator.

## Connect the Main Power Supply

**WARNING!** Turn the main power off before you make any electrical connections or set any switches inside the control panel box.

Wire the main power supply to control panel terminals in block J1 (see Figures 13 and 14). The installer is responsible for insuring that a separate, grounded circuit protected by a circuit breaker is between the control panel and the main power supply. All wiring should conform to applicable electrical codes, and all wiring and fittings should be weatherproof and/or suitable for burial.

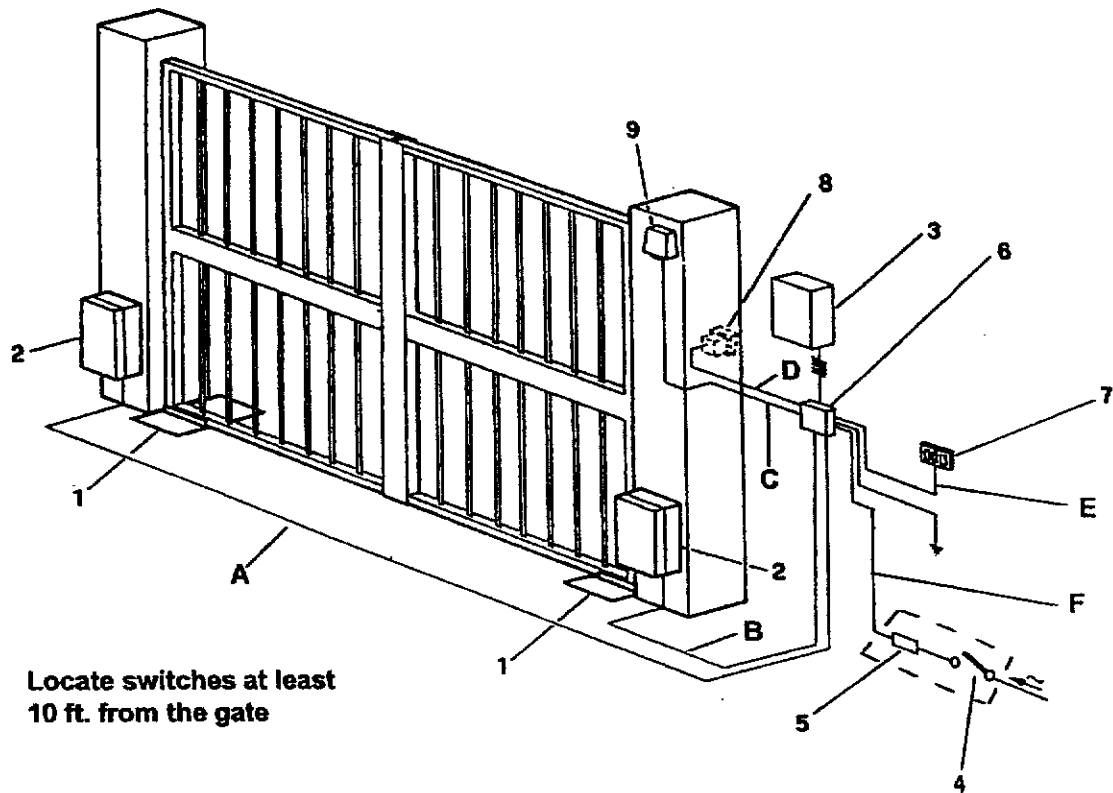

Locate switches at least 10 ft. from the gate

Gate System Parts	Wire Gauges for Given Power Source Voltage	
	220 VAC	115 VAC
1 750 hydraulic drive unit	A 4 X 14 AWG	4 X 14 AWG
2 750 hydraulic power unit	B 4 X 14 AWG	4 X 14 AWG
3 750 Control Panel box	C 3 X 18 AWG	3 X 18 AWG
4 Main power switch	D 5 X 18 AWG	5 X 18 AWG
5 Circuit breaker	E 5 X 18 AWG	5 X 18 AWG
6 Main junction box	F 4 X 14 AWG up to 414 ft (126 m)	3 X 14 AWG up to 130 ft (40 m) or 3 X 10 AWG up to 340 ft (104 m)
7 Switch for 750 Operator		
8 Switch for 750 Operator		
9 Radio receiver		

Figure 12. Typical layout of gate system with 750 Operators

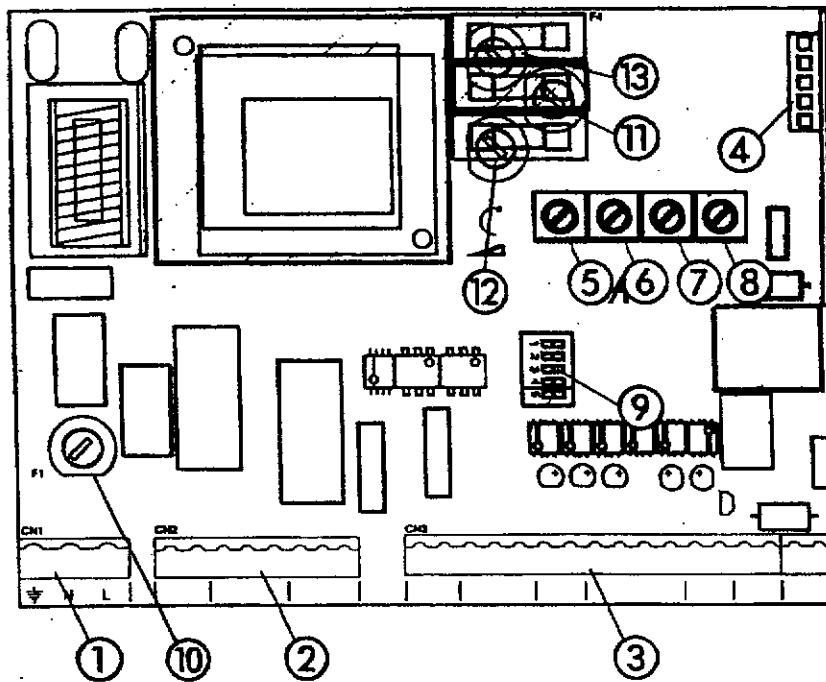

- 1 J1 terminal block for main power supply
- 2 J2 terminal block for connecting the operator(s)
- 3 J3 terminal block for low-voltage accessories
- 4 J4 quick connector port
- 5 Pressure adjustment potentiometer
- 6 Pause time potentiometer
- 7 Potentiometer for adjusting open/close time

- 8 Leaf delay potentiometer
- 9 DIP switch assembly

Fuses	220 VAC	115 VAC
10 F1, Main power	5 A	10 A
11 F2, Accessories	800 mA	800 mA
12 F3, Electric lock	1.6 A	1.6 A
13 F4, Microprocessor	250 mA	250 mA

**Figure 13. The 450 MPS control panel**

Connect the ground to the grounding terminal in block J1 and connect the power wires to the terminals labeled N (neutral) and L (phase).

For the purposes of installation you need to connect at least one normally open (N.O.) activating device for your operator(s).

**Caution:** The operators are grounded only by the grounded circuit the installer provides.

## Connect One Activating Device

**WARNING!** Turn the main power off before you make any electrical connections or set any switches inside the control panel enclosure

- If you have a two-leaf gate design, connect the activating device to terminals 18 and 19.
- If you have a one-leaf gate design, connect the activating device to terminals 16 and 17.

You use this activating device in the rest of the installation process. You can connect additional activating devices later.

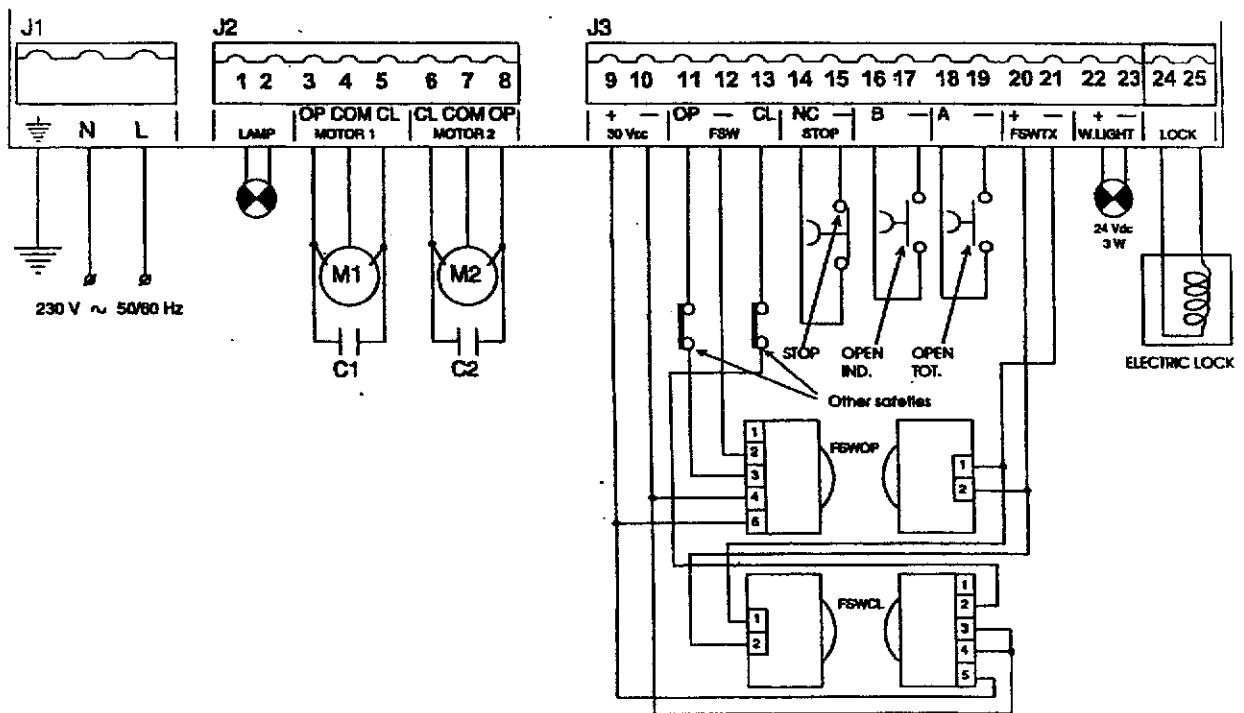

Figure 14. The terminal strip wiring of the 450 MPS

## Connect the Operator(s) to the Control Panel

**WARNING!** Turn the main power off before you make any electrical connections or set any switches inside the control panel box.

### Using a Junction Box

Connecting your operator(s) to the control panel may require the use of one or more junction boxes. Whether you need 0, 1, or 2 U.L. Listed junction boxes depends on your gate design (refer to Figure 15 below).

**Note:** The 750 Operators shipped for U.L. applications come with a U.L. listed junction box installed in the power unit box.

If any operator is more than 2 ft away from the U.L. Listed control panel enclosure, the connection must be made inside a junction box. Use a U. L. Listed cord grip where the operator cord enters the junction box; use conduit between the junction box and the enclosure.

### Connecting the Operator(s)

**Caution:** Do not use the terminal connections for Motor 2 (terminals 6, 7, and 8) if yours is a one-leaf gate design.

**Note:** If you have a one-leaf gate design, the operator must be connected to Motor 1 (terminals 3, 4, and 5).

If your gate system has one operator, connect the capacitor and the brown and black (or red and black) wires from your operator to the terminals 3 and 5 in block J2 for Motor 1. Connect the blue (or white) wire from the operator to terminal 4 for Motor 1.

**Note:** If you want to delay the closing of one gate leaf in a two-leaf gate design, be sure to connect its operator to Motor 1 (terminals 3, 4, and 5).

If your gate system has two operators, connect the second operator to terminals 6, 7, and 8 in block J2 for Motor 2. Connect the capacitor and the brown and black (or red and black) wires from the operator to terminals 6 and 8, and connect the blue (or white) wire from the operator to terminal 7 for Motor 2.

## Adjust the Pressures for the Operator

**WARNING!** You must decrease the pressures of the gate's opening and closing momentum before you operate the gate electrically. The pressure valves are not preset at the factory and may operate the gate leaf with enough force to endanger people and seriously damage the gate leaf itself.

The green and red screws on the front of the power unit are the valve adjustments that control the force of the gate leaf's opening and closing momentum (see Figure 16). For both valves, turning the screws clockwise increases the pressure, and turning them counterclockwise decreases the pressure.

The green valve adjusts the opening pressure, and the red valve adjusts the closing pressure (refer to page 14 for information on connecting the hydraulic lines). Turn both valves counterclockwise one full turn to decrease

the pressure now. Later, after you bleed the hydraulic system, you will have to fine-tune the pressure adjustments for safety.

**Note:** The green valve screw controls the opening pressure (and red, the closing pressure) *only if* the hydraulic line from nearest the green valve screw is connected to the side of the drive unit opposite the opening direction (refer to page 14).

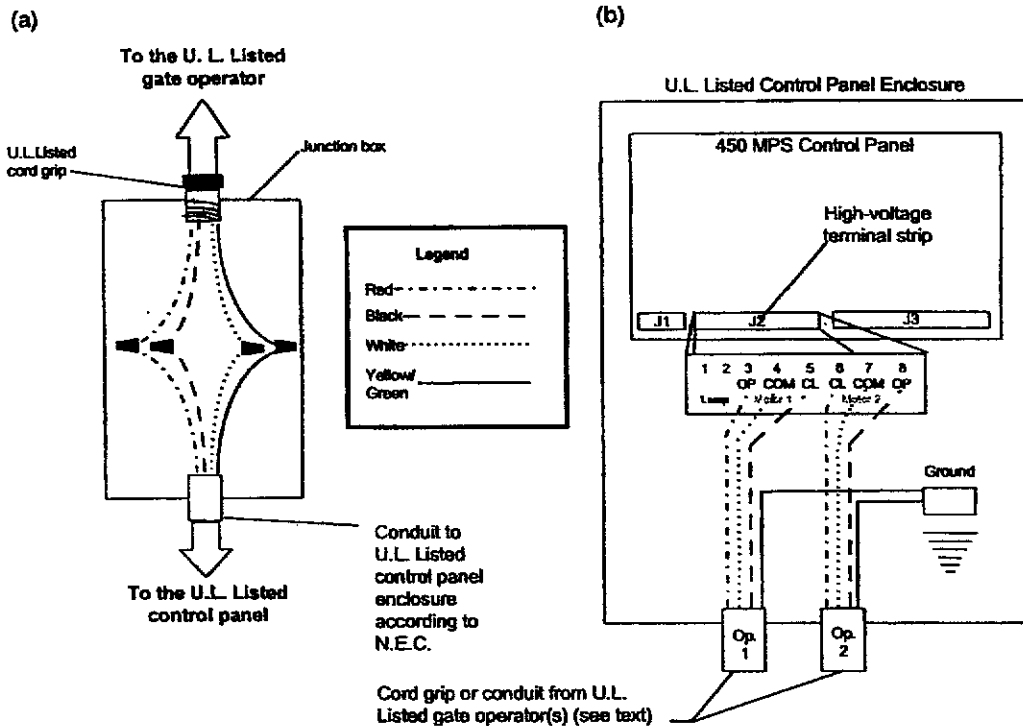

Figure 15. Wiring detail (a) inside the junction box and (b) from the junction box or operator to the high-voltage terminal strip on the 450 MPS control panel

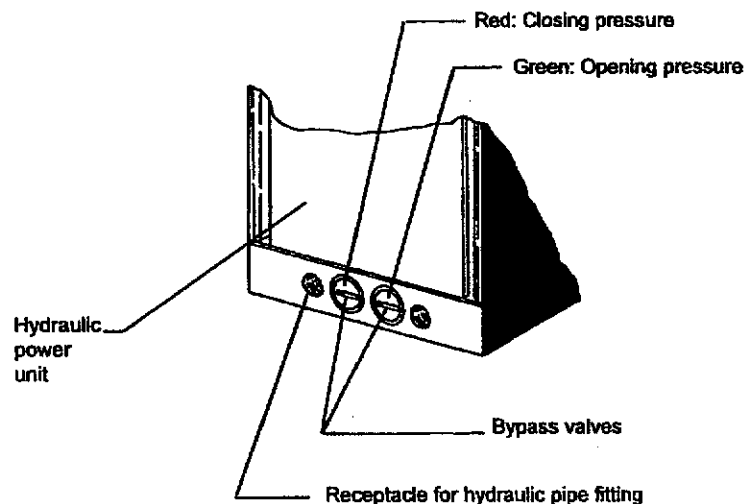

Figure 16. The bypass valves on the front of the power unit

## Check the Motor's Direction of Rotation

After you have connected the main power supply, one activating device, and the operator(s) to the control panel, you need to check the direction of rotation for each operator motor in your gate design.

To check a motor's direction of rotation, you must have three closed circuits on terminal block J3. Install one circuit between terminals 11 and 13, another circuit between terminals 13 and 21, and another circuit (or stop device) between terminals 14 and 15.

You cannot check the motor's direction of rotation without these circuits (jumpers) or the accessories. When properly prepared for testing, the LEDs DL2 and DL3 should be illuminated.

**WARNING!** Running the operator—even for testing purposes—without a connected reversing device is potentially dangerous. Do not place yourself within the path of the moving gate during your test.

Disengage the operator(s) with the Manual Release key, and open the gate by hand about halfway.

Next, engage the operator(s) with the Manual Release key so that you can check the rotation of the motor(s).

Turn on the main power and send an activating signal to the operator. The gate leaf (or leaves) should open. If a gate leaf closes, then you need to turn off the main power and reverse the connection of the brown and black (or red and black) wires on terminal block J2 for the operator controlling that leaf. Then you need to recheck the rotation direction again.

If your gate system has two operators, be sure the motor of each rotates in the correct direction.

After having completed your test of the motor's direction of rotation, replace any test circuits you installed (between terminals 11 and 13, between 13 and 21, and between 14 and 15) with the proper reversing

and stop devices. The instructions for installing such accessories follow.

## Connect Other Devices

**WARNING!** Turn the main power off before you make any electrical connections or set any switches inside the control panel box.

Now you can connect additional reversing and activating devices to the control panel. Refer to Figure 13 for the general control panel layout, and refer to Figure 14 for the layout of the terminal strip.

**Note:** The 450 MPS control panel allows a maximum accessory load of 500 mA.

**Power Supply for Accessories:** You can access a 30 VDC output for supplying power to accessories that require DC voltage through terminals 9 and 10 (located above the label *30 Vcc*) on terminal block J3. In most cases, this source can be used to power 24 VDC accessories.

**Reversing Devices:** Reversing devices include photocells, inductive loops, and so forth. All of the reversing devices should have contacts of the normally closed (N.C.) type. Where you connect a device depends on whether you want the device to operate during opening or during closing.

**Note:** A reversing device is required for a U.L. recognized installation.

**Caution:** Failure of a reversing device that operates during opening causes a gate to lock in the closed position and requires the use of the manual key release.

To wire photocells, refer to Figure 14 (see FSWOP for opening photocells, and FSWCL for closing photocells—connect the photocells exactly as shown). See Figure 17 for the wiring of inductive loops. In either case, if you have multiple devices, wire them in series.

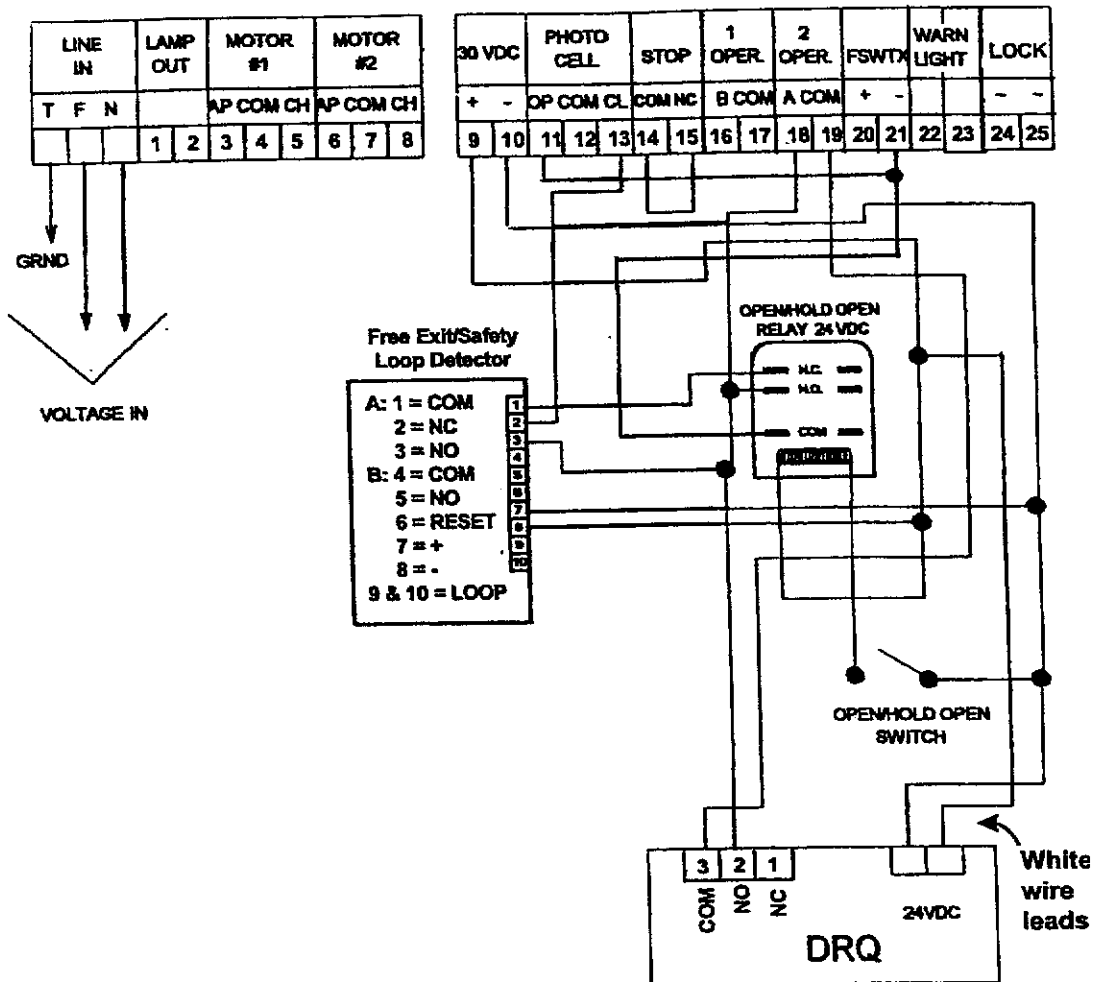

**Figure 17. Wiring diagram showing loop detector**

FAAC International, Inc., strongly recommends you install reversing devices. If you choose not to install such devices, then you must install the necessary circuit(s) for the control panel to work.

- If you do not install an opening reversing device, install a circuit between 11 and 21 on terminal block J3.
- If you do not install a closing reversing device, install a circuit between 13 and 21 on terminal block J3.

In addition, terminal block J3 requires a fail-safe connection for the photocells. Connect the photocells to terminals 20 and 21.

**Activating Devices and Radio Receiver:** The activating devices and radio receiver for your gate must have normally open (N.O.) contacts. If you have only one gate leaf, connect such devices to terminals 16 and 17. If your gate has two leaves, connect the devices to terminals 18 and 19.

In addition, terminal block J3 requires a fail-safe connection for the transmitter of your photocells. Connect the transmitter to terminals 20 and 21 in the FSWTX grouping.

See Figure 18 for how to wire a three-wire receiver and Figure 19 for how to wire a four-wire receiver.

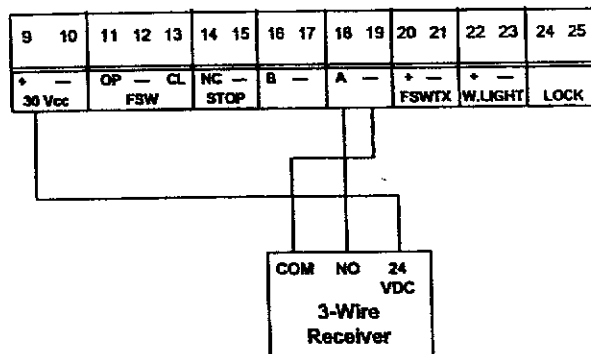

**Figure 18. Connect a three-wire receiver**

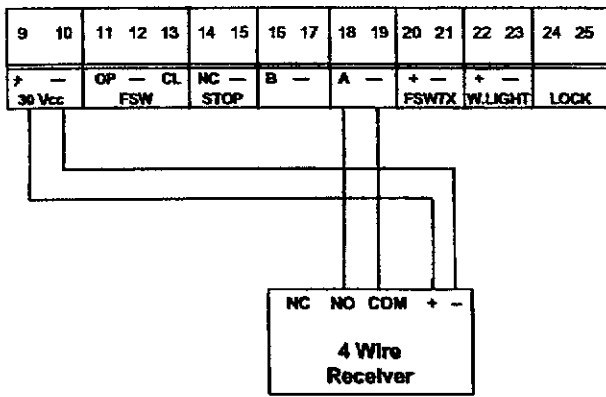

Figure 19. Connect a four-wire receiver

**Decoder Card:** If you are installing the Digicard magnetic card reader, or the Digikey keyboard, use the quick-fit connector J4 for the DS (formerly the MD01) decoder card (see Figure 13).

**Open/Hold Open Device:** To open and hold open the gate, an Open/Hold Open device must make a set of contacts across terminals 18 and 19 (or 16 and 17) and must break a set of contacts between terminals 13 and 21 (see Figure 20).

**Stop Button:** The stop button you install must have normally closed (N.C.) contacts. Multiple stop buttons must be wired in series. Connect your stop device between terminals 14 and 15.

**Note:** If you choose not to install a stop button, you must install a circuit between these terminals for the control panel to work.

**The LED Indicators:** The five light-emitting diodes (LEDs) on the control panel can be used to check for the proper functioning of the devices you attach to the control panel. The LED lights are on whenever the contacts are closed across each of the respective terminals.

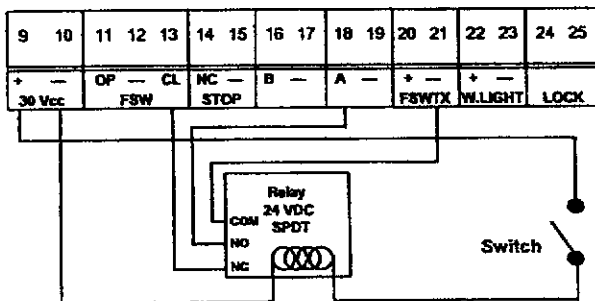

Figure 20. Connect an Open/Hold Open device with an external relay

DL1 and DL2 should illuminate only when an activating signal is sent for 2 and 1 gate leaves, respectively. DL3 should be illuminated except when the stop button is pressed. DL4 and DL5 should be illuminated except when the reversing devices, for opening and closing, respectively, are triggered. Use the LEDs and the table below to determine if the accessory devices you have installed are operating properly.

LED	On	Off
DL1, Open 2 leaves	Command active	Command inactive
DL2, Open 1 leaf	Command active	Command inactive
DL3, Stop	Command not active	Command active
DL4, FTSW Open	Opening reversing devices not triggered	Reversing device triggered
DL5, FTSW Close	Closing reversing devices not triggered	Reversing device triggered

**Electric Lock:** An electric lock can make use of the reversing stroke function controlled by DIP switch 5. A reversing stroke is a short closing phase that allows the electric lock time to disengage itself before the operator starts its opening. Use DIP switch 5 if necessary for your lock to function correctly. Connect your lock to the terminals 24 and 25. The terminals provide 12 VAC pulsed power.

Connect a magnetic locking device as shown in Figure 21, below.

**Warning Light:** Connect a warning light to terminals 22 and 23 in the group labeled *W.LIGHT* in terminal block J3. The terminals provide an output voltage of 30 VDC, maximum power 3 Watts. This output voltage will power most 24 VDC warning lights.

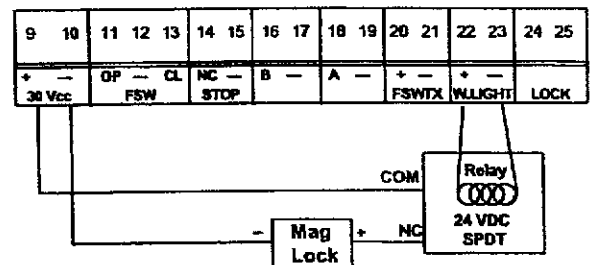

Figure 21. Connect a mag lock to the 450 MPS control panel

Note: The behavior of the warning light varies according to the logic you have set:

**Logics A, S, E, EP, and B:** The warning light is on steadily during opening and the pause phase. During closing, the light flashes.

**Logic C:** The warning light is on steadily during opening and flashes during closing.

## Set Other Operating Controls

**WARNING!** Turn off the main power before you make any electrical connections or set any switches inside the control panel box.

Note: Some DIP switch assemblies are labeled differently depending on their date of manufacture. OPEN indicates *off* and ON indicates *on*.

You need to set DIP switches and adjust some potentiometers on the control panel for your gate's operation. The 450 MPS Control Panel has 5 DIP switches and 4 potentiometers that control a wide range of functions.

### Set DIP Switches

**Switches 1, 2, and 3 (Operating Logic):** The 450 MPS Control Panel offers six operating modes:

- A (automatic)
- S (security)
- E (semi-automatic)
- EP (semi-automatic, step by step)
- B (manned, pulsed)
- C (manned and constant)

Refer to the operating logic tables later in these instructions for more detail.

Switches 1, 2, and 3 control the operating logic according to the following scheme:

Logic	DIP Switch		
	1	2	3
A	off	off	off
S	on	off	off
E	off	on	off
EP	on	on	off
B	on	on	on
C	off	off	on

**Switch 4 (Reversing Device Behavior on Closing):** Refer to the operating logic tables later in these instructions and to the chart below for how to set DIP switch 4.

Gate Behavior During Closing	DIP Switch 4
Gate immediately reverses its direction	off
Gate stops and reverse its direction when reversing device is no longer triggered	on

**Switch 5 (Reversing Stroke):** Some electric locks require a reversing stroke to disengage the lock. If your lock requires this reversing stroke, set DIP switch 5 according to the following chart.

Reversing Stroke	DIP Switch 5
Not activated	off
Activated	on

### Adjust the Potentiometers

The four potentiometers control the torque (or pressure), the pause time between opening and closing, the opening/closing time of operation, and the leaf delay on closing.

**Torque (Pressure):** The torque (or pressure) potentiometer on the 450 MPS must be turned all the way clockwise for the 750 Operator. The potentiometer controls voltage to the operator, which can affect the life of the operator's motor. The torque/pressure potentiometer cannot be used to adjust the operator's hydraulic operating pressures.

**Caution:** Failure to turn the torque/pressure potentiometer to maximum in the clockwise direction jeopardizes the life of the motor of your operator.

**WARNING!** Adjust the operating pressure on the 750 Operator only by means of the hydraulic bypass valve screws. See pages 19 and 25.



**Pause Time:** The pause time between opening and closing can be adjusted from 5 to 240 seconds. Turn the potentiometer clockwise to increase the pause time and counterclockwise to decrease the pause time.

**Opening/Closing Time:** The opening/closing time is adjustable from 10 to 62 seconds. The approximate opening/closing time for a 90-degree opening is 18 seconds. Turn the potentiometer clockwise to increase the time and counterclockwise to decrease the time.

For optimal operation, set the time so that the motor remains active for a couple of seconds after the leaf has reached its limit stop for opening and for closing.

**Leaf Delay:** You may choose to delay one leaf on closing for overlapping gate leaves. Be sure the operator on the leaf for delayed closing is connected to Motor 1. On opening, the leaf connected to Motor 2 is delayed 2.5 sec.

**Note:** You cannot *adjust* this opening delay of the operator connected to Motor 2. However, you can avoid the opening delay—and closing delay—by connecting both operators (and their capacitors) to Motor 1.

The time is adjustable from 0 to 28 seconds. Turn the potentiometer clockwise to increase the time and counterclockwise to decrease the time.

**Note:** If one-leaf gate designs, be sure to set the potentiometer for leaf delay to its minimum (0 seconds).

**Note:** If the opening/closing time is set at less than the leaf delay time, the delayed leaf closes at the end of the closing time.

## Bleeding the Hydraulic System

For the 750 Operator to work smoothly, it is critical that you bleed the hydraulic system of any air. Before you bleed the system, be sure that you have removed the vent screw on the top, left side of the power unit.

One bleeding operation consists of the following:

- Running the gate leaf through three open-close cycles
- Allowing the gate leaf system to sit idle for 5 minutes
- Releasing the air from each end of the drive unit through the bleed screw holes (see Figure 18)

You need to bleed the hydraulic system before setting the gate up for normal operation.

To run the gate leaf through an open-close cycle, make sure the gate is set up for hydraulic operation (the Manual Release lever is turned up) in the A mode. Activate the gate once to open, pause, and then automatically close. The gate needs to open and close three times.

Then you need to allow the gate to sit idle for a full five minutes. During this time, you can disengage the hydraulic system (turn the Manual Release lever down) and make sure that the top cover is removed from the drive unit to allow you access to the bleed screws on either end of the unit.

With the hydraulic system disengaged, open the gate leaf by hand to a half-opened position. Re-engage the hydraulic system.

If you have a CBAC model of the 750 Operator (with hydraulic locking in the fully opened and fully closed positions), then first try to move the gate leaf. If you are unable to make the gate leaf move, then you do not need to bleed the hydraulic system.

If you do need to bleed the hydraulic system, then next open the bleed screw that is on the same side of the drive unit as you are. Open the screw less than a full turn. Next, pull the gate leaf toward you until just oil (and no bubbles) comes out of the drive unit. Then close the bleed screw.

Next, release the air from the other end of the drive unit in the same manner.

Finally, test the automatic operation of the gate. If the gate does not operate smoothly, then repeat the bleeding process again.

## Adjusting the Bypass Valves

The pressure a gate leaf applies to an obstacle in its path is determined by the bypass valve adjustment. FAAC recommends that the gate should stop when it meets with a force of more than 33 lb (15 kg).

**WARNING!** The pressure valves may operate the gate leaf with enough force to endanger people and seriously damage the gate leaf itself. Increase the pressures in small increments (1/4 turn), and set the pressure adjustments at the *minimum* level necessary for the gate's operation.

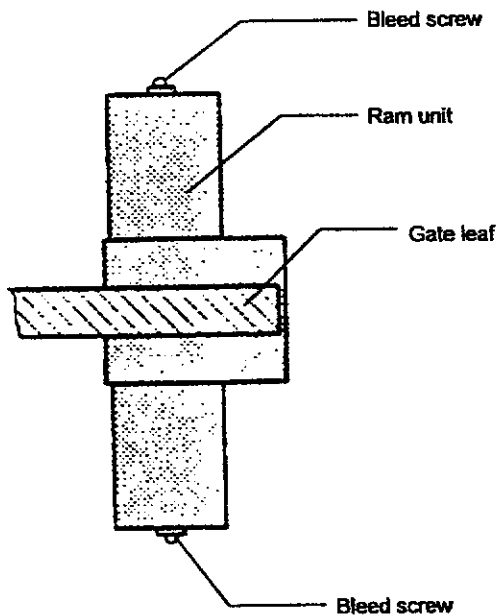

Figure 22. The location of the bleed screws on the drive unit, top view

The red and green screws on the front of each power unit are the valve adjustments that control the force of the gate leaf's closing and opening. For both screws, turning the screws clockwise increases the pressure and turning them counterclockwise decreases the pressure.

Fine tune the pressures for both opening and closing after you have installed the control panel for the 750 Operator. Set the pressures at the *minimum* necessary to open or close the gate leaf.

**Note:** The speed of the gate's movement can be affected slightly by the bypass valve adjustment.

**WARNING!** The pressure the gate leaf applies to the obstruction is determined by the bypass valve adjustment. It is the installer's responsibility to make sure the pressures are correctly set.

# Installing an Extension Arm

Some gate installations do not meet the geometrical constraints shown in Figure 2. In those situations, the 750 Extension Arm option can be used along with the 750 drive unit, power unit, and control panel to install an unobtrusive gate operator.

Using the 750 Extension Arm means that you do not have to permanently remove any leaf hinges, the gate leaf does not need to form a 90-deg angle on the bottom corner nearest the gate post, and the relative location of the rotation axis is not so restricted.

The geometrical constraint for using the 750 Extension Arm is that the center of the splined shaft on the drive unit *must* be within 6 in. (15.25 cm) of the axis of rotation of the gate leaf.

**WARNING!** The farther away the splined shaft is from the gate's axis of rotation, the greater the risk of danger from pinch points.

Install the drive unit so that the splined shaft is as near as possible to the gate's rotation axis and is directly beneath the center of the fully closed gate leaf.

You need to position the extension collar (see Figure 23) so that it smoothly slides within the extension U from the fully closed to the fully opened position. Note

that the position of the extension collar is affected by the overlap of the extension bar and extension U.

Attach the 750 extension collar to the bottom of the gate leaf with a 7/16 in. (1.1 cm) bolt.

Weld together the extension bar and extension U according to Figure 23.

**Caution:** Do not weld anything to or on the inside of the sleeve of the splined shaft.

Next, weld the outside of the sleeve for the splined shaft solidly to the inside of the hole in the end of the extension bar.

Follow the rest of the instructions for installing the 750 Operator. With an extension arm, you need not worry about installing a gate leaf shoe nor about installing the gate leaf in the shoe. Instead, you will install one end of the welded extension arm over the splined shaft and the other end around the extension collar.

In addition, you will need to provide a washer beneath the extension collar to keep the extension U from falling off the collar. You also need to shield any pinch points around the extension arm.

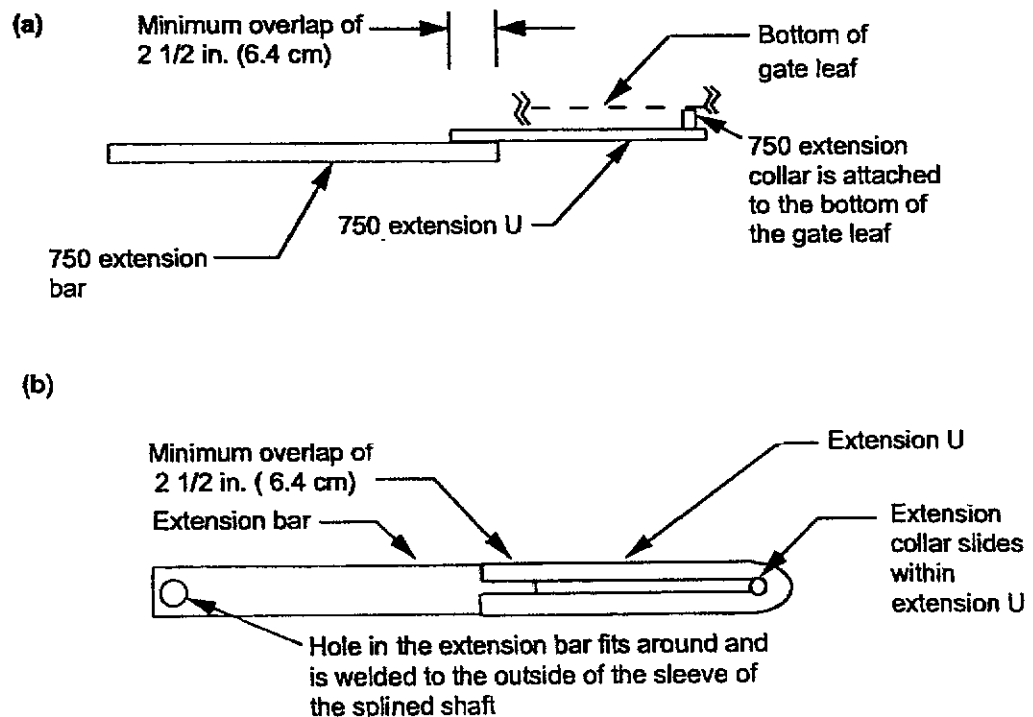

Figure 23. The 750 Extension Arm, (a) side view and (b) top view

# Maintenance

## The 750 Operator

The FAAC recommended maintenance schedule varies according to the frequency of use of the operators, whether lightly used operators (once or twice an hour) or heavily used operators (many cycles per hour).

### Check the oil.

To check the oil level correctly, remove the oil filler cap on the top of the power unit. A dip stick is attached to the bottom of the cap for checking the oil level as shown in Figure 24.

Light duty use: check once per year  
Heavy duty use: check every 6 mo

### Change the oil.

Changing the oil completely in the hydraulic system of the 750 Operator requires removing the power unit and drive unit from their installed positions unless you are able to pump the oil out of both units.

Light duty use: change every 4 yr  
Heavy duty use: change every 2 yr

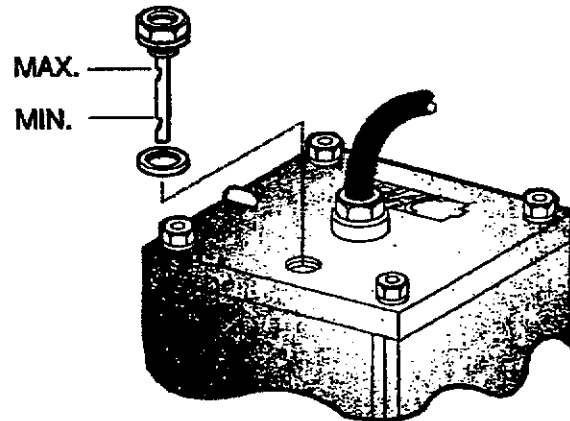

Figure 24. When you check the oil, make sure the oil level falls between the minimum and maximum marks on the oil dip stick

### Check the pressure settings.

Light duty use: check once per year  
Heavy duty use: check every 6 mo

### Check all reversing devices.

Every six months, you should verify that all installed reversing devices work properly.

## The Control Panel

The control panel requires no maintenance.

# Troubleshooting

**WARNING!** Before you do any work on the control panel, be sure to turn off the main power.

**Problem:** The gate does not respond to an activating signal.

### Solution:

Verify that you have correctly wired the operator to the control panel.

Verify that the LED DL3 is on. If it is not illuminated, then check the fuses on your control panel.

If the LED DL3 is not illuminated and your fuses are okay, then the stopping device is being triggered and is preventing the gate from responding to your signal. If

you have no stopping device installed, then be sure you have installed a jumper across the appropriate terminals.

Verify that your activating device works properly. Either DL1 or DL2 (depending on your gate design) should illuminate when you signal the gate to close (or open) and LED DL3 should be on. If either DL1 or DL2 does not illuminate when you signal the gate, then the problem may be in your activating device. Short across the appropriate terminals. If the short causes the gate to close (or open), then the problem is in the activating device. Repair or replace the device.

**Problem: The radio controlled opener does not open the gate.**

**Solution:**

Check the light on the front of the remote transmitter. It should illuminate when you signal the gate. If it does not illuminate and if the batteries are okay, repair or replace the transmitter.

Verify that the wiring for the radio controlled device is correct.

Check the wiring for the antenna and correct it if necessary.

Check DL1 and DL2. One should illuminate when the transmitter button is pressed.

Determine if the fault is in the receiver by temporarily connecting a push button device across the appropriate terminals. If such a push button device opens the gate, repair or replace the receiver.

**Problem: The gate doesn't open (or close) though the motors are running.**

**Solution:**

Make sure that the motor is running in the right direction, and make sure the Manual Release mechanism has fully engaged the hydraulic system.

Increase the bypass pressure in small  $\frac{1}{4}$  turn increments to see if the hydraulic system needs more pressure.

**Problem: The gate opens but does not close.**

**Solution:**

Make sure you have selected the desired operating mode.

Verify that the reversing devices are working properly. DL4 or DL5 should illuminate when a reversing device is triggered. If either does not illuminate, then one of your reversing devices is preventing the gate from

responding to your signal. Check your reversing devices.

If no reversing devices are installed, make sure a circuit is installed between appropriate terminals.

If the motor is running, insure that the bypass valves are correctly adjusted. Increase the bypass pressure in small  $\frac{1}{4}$  turn increments to see if the hydraulic system needs more pressure.

**Problem: The gate does not fully open (or close).**

**Solution:**

Increase the bypass pressure(s) to see if the hydraulic system needs more pressure.

Check the operator's motor run time selection. You should set a time that is just longer than the rated speed of your model of operator. For example, because the 400 CBAC has a rated opening time of 17 sec, you should select a time that is just longer than the opening time.

Check to see that there are no obstructions in the path of the gate or that the hinges are not binding.

**Problem: The operator doesn't work smoothly and the gate jerks as it opens and closes.**

**Solution:**

Check the oil level in the operator.

Make sure the Manual Release mechanism has fully engaged the hydraulic operation of the operator.

Bleed the air from the hydraulic system by cycling the gate (opening and then closing) 10 times and pausing for a couple of minutes between cycles.

Make sure that a flexible gate leaf is not the problem. If the gate leaf flexes, then stiffen the gate or use a slower operator.

# Exploded View 750 CBAC

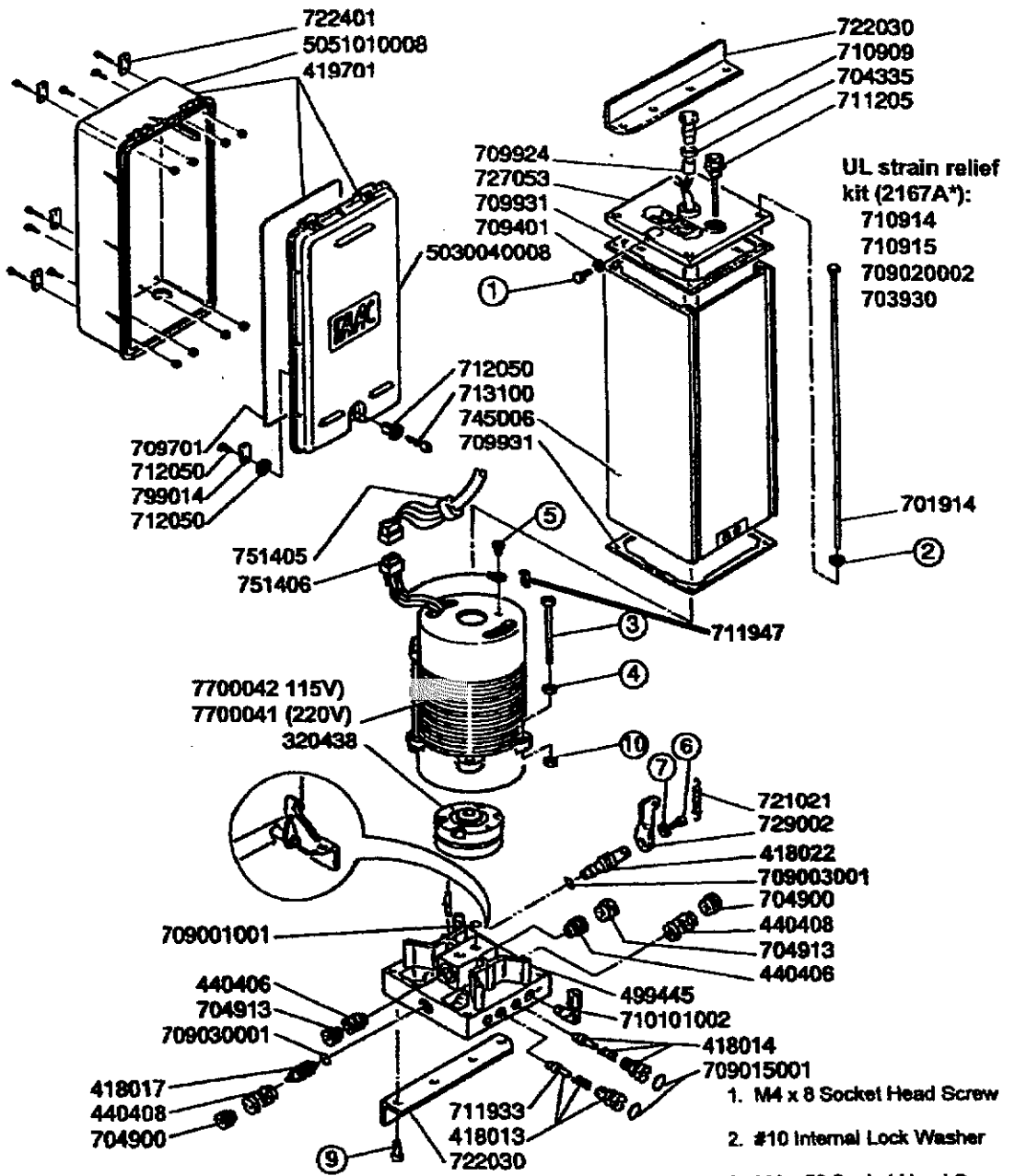

UL strain relief  
kit (2167A\*):  
710914  
710915  
709020002  
703930

1. M4 x 8 Socket Head Screw
2. #10 Internal Lock Washer
3. M4 x 50 Socket Head Screw
4. 4 mm Lock Washer
5. M4 x 8 Socket Head Screw
6. M4 x 8 Socket Head Screw
7. 4 x 12 mm Machine Washer
9. M5 x 8 Socket Head Screw
10. M4 x .70 Hex Nut

cod. 923018

0.2	09.93	00.00	3.90.809.000
-----	-------	-------	--------------



# Exploded View

# 750 Ram Parts

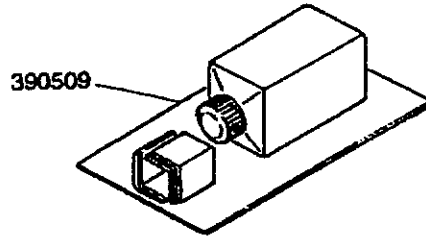
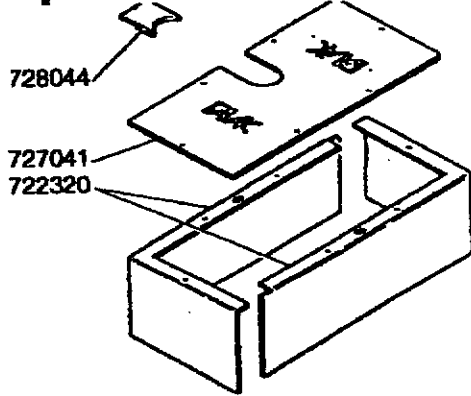

Order part no. 730902 for old 6-splined shaft

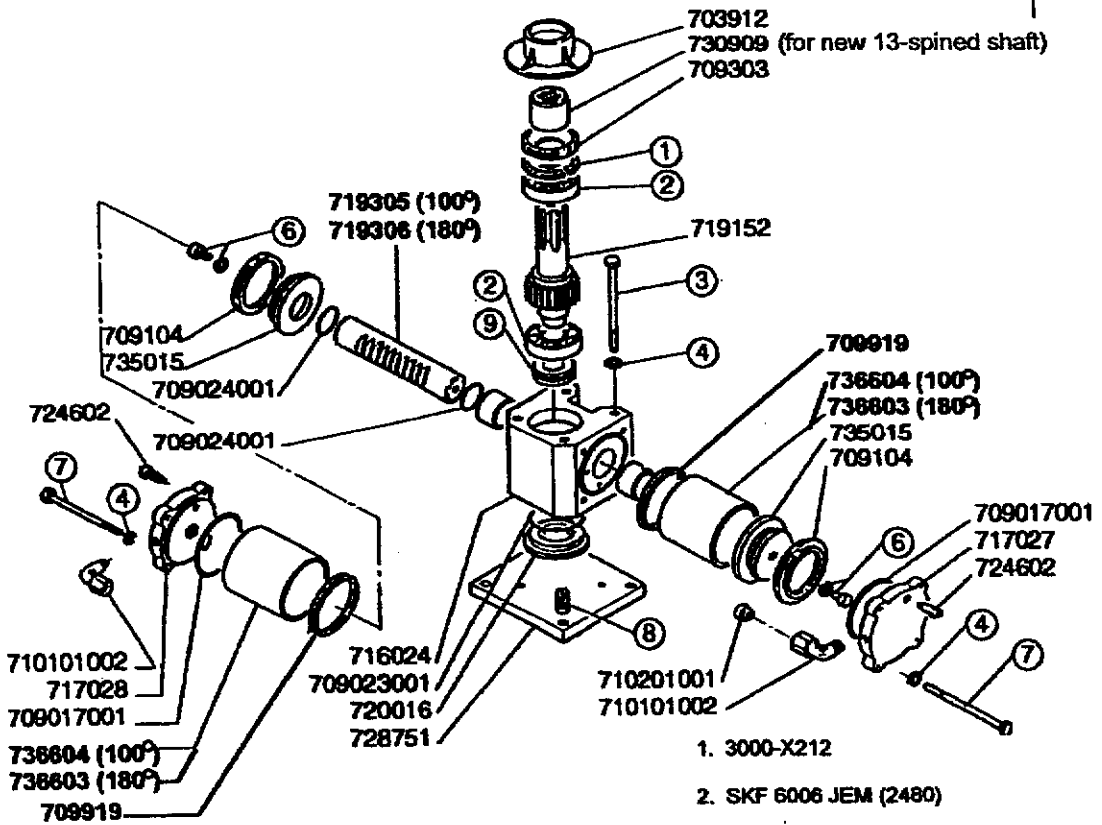

1. 3000-X212
2. SKF 6006 JEM (2480)
3. M8 x 100 Hex Head Bolt
4. 8 mm Lock Washer
6. M10 x 25 Hex Head Bolt w/Lock
7. M8 x 105 Hex Head Bolt (100°)  
M8 x 140 Hex Head Bolt (180°)
8. M12 x 35 Socket Head Set Screw
9. SKF 51105 (2339)

2550

cod. 9230211

0.0	01.95	00.00	3.90.817.000
-----	-------	-------	--------------



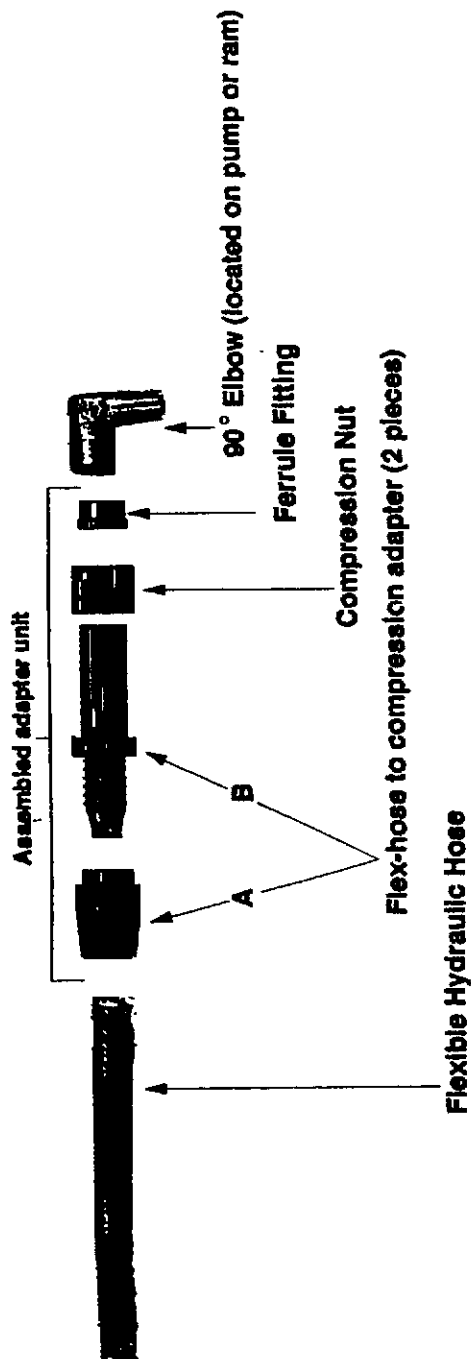

**Procedures for installing flex-hose to copper adapter**

**Note:** The parts that make up the hose adapter are shown in the proper order

1. Screw item A onto hydraulic hose (left hand thread - counter-clockwise) until tight
2. Screw item B into item A (now on hose). To get the threads to catch you must push B into A as you turn it (right hand thread - clockwise)
3. Slide compression nut onto B (in the orientation shown)
4. Slide ferrule onto B (with larger end toward compression nut)
5. Insert end of B into 90° elbow (located on pump or ram)
6. Tighten compression nut securely while holding assembled adapter unit fully into elbow
7. Once you have tightened the compression nut, the ferrule will be permanently crimped onto item B, you can remove the hose (including adapter kit above) from pump or ram and it will remain assembled

TITLE: 750 Flex-Hose Adapter Kit	
DRAWN BY: Lynn S. Powell	DATE: 6/20/08
SCALE: N/A	DRAWING: 1 of 1
COMPANY: FAAC International Inc.	



### Limited Warranty

*To the original purchaser only:* FAAC International, Inc., warrants, for twenty-four (24) months from the date of invoice, the gate operator systems and other related systems and equipment manufactured by FAAC S.p.A. and distributed by FAAC International, Inc., to be free from defects in material and workmanship under normal use and service for which it was intended, *provided* it has been properly installed and operated. FAAC International, Inc.'s obligations under this warranty shall be limited to the repair or exchange of any part of parts manufactured by FAAC S.p.A. and distributed by FAAC International, Inc. Defective products must be returned to FAAC International, Inc., freight prepaid by purchaser, within the warranty period. Items returned will be repaired or replaced, at FAAC International, Inc.'s option, upon an examination of the product by FAAC International, Inc., which discloses, to the satisfaction of FAAC International, Inc., that the item is defective. FAAC International, Inc. will return the warranted item freight prepaid. The products manufactured by FAAC S.p.A. and distributed by FAAC International, Inc., are not warranted to meet the specific requirements, if any, of safety codes of any particular state, municipality, or other jurisdiction, and neither FAAC S.p.A. or FAAC International, Inc., assume any risk or liability whatsoever resulting from the use thereof, whether used singly or in combination with other machines or apparatus.

Any products and parts not manufactured by FAAC S.p.A. and distributed by FAAC International, Inc., will carry only the warranty, if any, of the manufacturer. This warranty shall not apply to any products or parts thereof which have been repaired or altered, without FAAC International, Inc.'s written consent, outside of FAAC International, Inc.'s workshop, or altered in any way so as, in the judgment of FAAC International, Inc., to affect adversely the stability or reliability of the product(s) or has been subject to misuse, negligence, or accident, or has not been operated in accordance with FAAC International, Inc.'s or FAAC S.p.A.'s instructions or has been operated under conditions more severe than, or otherwise exceeding, those set forth in the specifications for such product(s). Neither FAAC S.p.A. or FAAC International, Inc., shall be liable for any loss or damage whatsoever resulting, directly or indirectly, from the use or loss of use of the product(s). Without limiting the foregoing, this exclusion from liability embraces a purchaser's expenses for downtime or for making up downtime, damages for which the purchaser may be liable to other persons, damages to property, and injury to or death of any persons. Neither FAAC S.p.A. or FAAC International, Inc., assumes nor authorizes any person to assume for them any other liability in connection with the sale or use of the products of FAAC S.p.A. or FAAC International, Inc. The warranty hereinabove set forth shall not be deemed to cover maintenance parts, including, but not limited to, hydraulic oil, filters, or the like. No agreement to replace or repair shall constitute an admission by FAAC S.p.A. or FAAC International, Inc., of any legal responsibility to effect such replacement, to make such repair, or otherwise. This limited warranty extends only to wholesale customers who buy directly through FAAC International, Inc.'s normal distribution channels. FAAC International, Inc., does not warrant its products to end consumers. Consumers must inquire from their selling dealer as to the nature and extent of that dealer's warranty, if any.

**This warranty is expressly in lieu of all other warranties expressed or implied including the warranties of merchantability and fitness for use. This warranty shall not apply to products or any part thereof which have been subject to accident, negligence, alteration, abuse, or misuse or if damage was due to improper installation or use of improper power source, or if damage was caused by fire, flood, lightning, electrical power surge, explosion, wind storm, hail, aircraft or vehicles, vandalism, riot or civil commotion, or acts of God.**

FAAC International, Inc.  
303 Lexington Avenue  
Cheyenne, WY 82007