



# REBEL™ Adjustable Height Thru-Beam Photo-Eye

## INSTALLATION INSTRUCTIONS

Model #MIRM-S2 & #MIRM-S2-50



**IMPORTANT:**  
**READ AND UNDERSTAND ALL INSTRUCTIONS BEFORE BEGINNING INSTALLATION.**

The **REBEL™** thru-beam photo-eye sensor is designed to transmit an infrared light beam from an emitter to a receiver and provide flexible mounting options for various applications. If the beam is interrupted by an object or person, signals are sent to the door operator to stop and/or reverse the door.

### 1- Parts List

PART NUMBER	DESCRIPTION	PART NUMBER	DESCRIPTION
<b>MIRM-S2</b>	PE, FAIL-SAFE, <b>REBEL™</b> KIT 30 FT	<b>MIRM-S2-50</b>	PE, FAIL-SAFE, <b>REBEL™</b> KIT 50 FT
(1) MIRM-E2	MON, CABLE TX EYE, 30 FT EXT POWER	(1) MIRM-E2-50	MON, CABLE TX EYE, 50 FT EXT POWER
(1) MIRM-R2	MON, CABLE RX EYE, 3 FT EXT POWER	(1) MIRM-R2	MON, CABLE RX EYE, 3 FT EXT POWER
(1) MIR-S2-BK	PAIR OF <b>REBEL™</b> HOUSING UNITS	(1) MIR-S2-BK	PAIR OF <b>REBEL™</b> HOUSING UNITS
<b>OPTIONAL:</b>		<b>OPTIONAL:</b>	
MIR-S2-EK	<b>REBEL™</b> MOUNT EXTENSION KIT	MIR-S2-EK	<b>REBEL™</b> MOUNT EXTENSION KIT

### 2- Eye Installation

Standard Mounting Bracket and Mount Extension Kit Assembly Diagrams

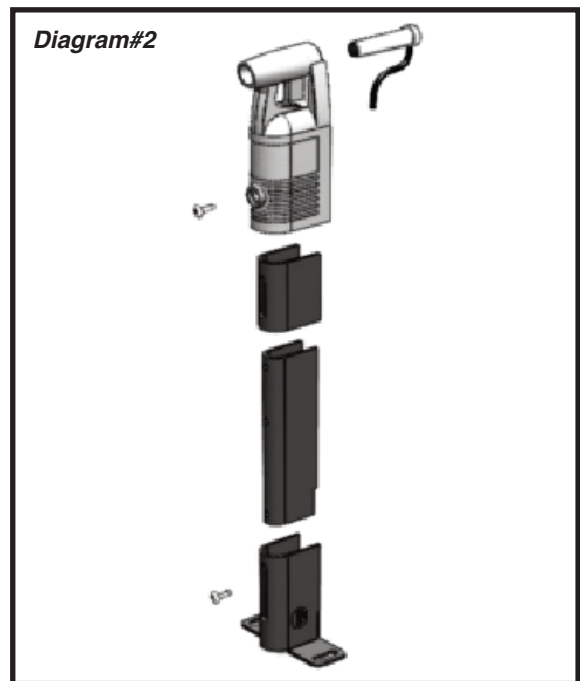
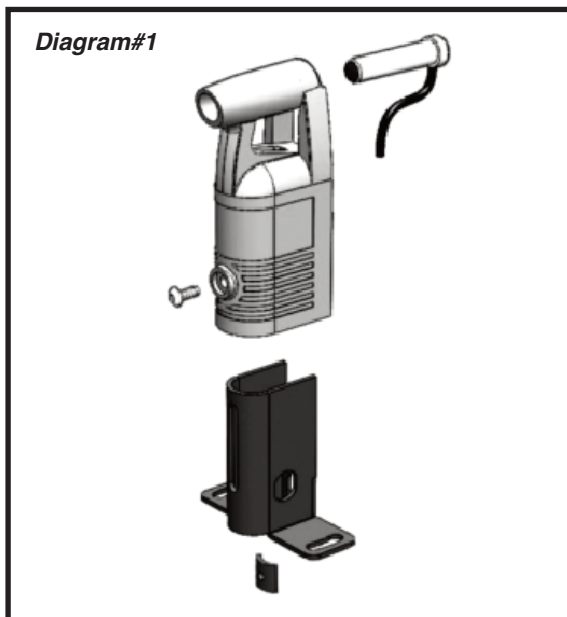

# 3- Mounting

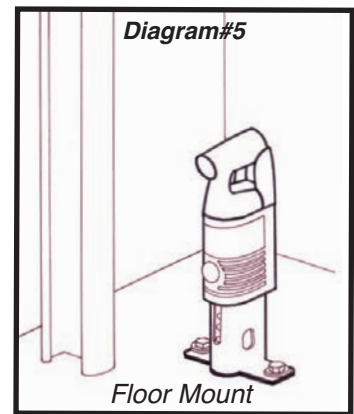
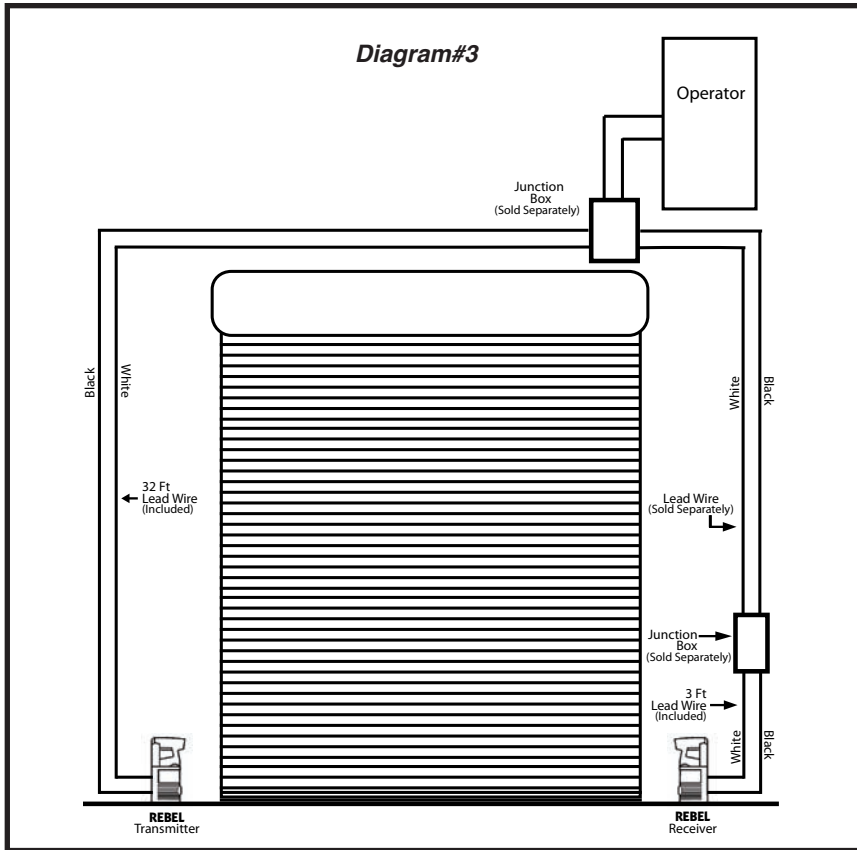

## MOUNTING INSTRUCTIONS

- 1- Select a stable mounting location with a clear line of sight to detect obstructions, where the light beam could not be obstructed by plants, leaves, etc.
- 2- Determine Wall OR Floor mounting direction. For ease of alignment, both transmitter and receiver should be mounted in the same manner facing one another.
- 3- Attach Mounting Brackets to both the EMITTER and RECEIVER and adjust to desired height.
- 4- Install as per wiring diagram in conjunction with all Federal, State and Local codes.
- 5- If you are installing the optional **REBEL™** Mount Extension Kit, reference the Assembly Diagram#2 shown on page (1).

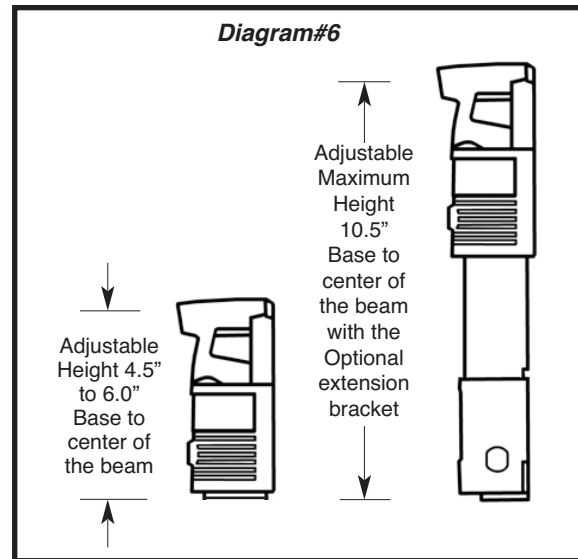

Optional **REBEL™** Mount Extension Kit  
MIR-S2-EK

## 4- Wiring Connections

### JUNCTION BOX WIRING

- 1- Wire nut both black photoeye wires together plus a length of wire that will reach into the operator terminal strip.
- 2- Do the same for the white wires.
- 3- Each wire nut should have 3 wires: Two photoeye wires plus one wire to go to the operator terminal strip.
- 4- Connect one of these wires to your safety input and the other to a low voltage common terminal. Not polarity sensitive.

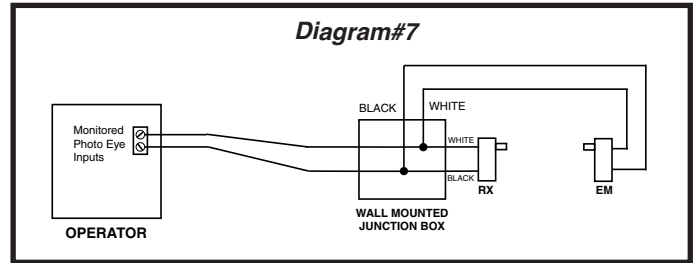

## 5- Technical Specifications

Detection Technology	Infrared Thru-Beam
Infrared Wavelength	940nm
Infrared Beam Range	30/50 feet
Response Time	<20msec
Alignment Angle	+ 10
Operating Temperature	-40°F to +185°F (-40° C to 85° C)
Power Supply	Monitored Photo Eye Terminals
Current Consumption	30mA

Cable Length	Rx: 3 Ft. Em Ext: 32/52 Ft.
Mounting Method	Static
Enclosure Material	Aluminum with Epoxy Potting
Enclosure Size	Base & Boot: 5" x 3 1/2" x 2 1/2" Extension Bracket: 5 1/2" x 1/2" x 2"
Degree of Protection	NEMA 4
Certification	UL325 Pending
Rating	Class 2, NEMA 4, IPE 5

## 6- Trouble Shooting Tips

### Emitter Indicators

LED COLOR	OK STATUS	FAULT	SOLUTION
GREEN	ON = NORMAL OPERATION	OFF = NO POWER	CHECK WIRING

### Receiver Indicators

LED COLOR	OK STATUS	FAULT	SOLUTION
GREEN	ON = NORMAL OPERATION	OFF = NO POWER	CHECK ALIGNMENT CHECK WIRING
RED	OFF = NORMAL OPERATION	ON = OBSTRUCTION	REMOVE OBSTRUCTION

### Control Unit Indicators

LED COLOR	OK STATUS	FAULT	SOLUTION
GREEN	FLASHING = NORMAL OPERATIONS	OFF = NO POWER OR OBSTRUCTION	CHECK WIRING
RED	OFF = NORMAL OPERATION	ON = OBSTRUCTION	REMOVE OBSTRUCTION CHECK WIRING

## 7- Warranty

We will replace within two years of shipment from our factory, any **REBEL™** subject to normal use which is found to have defective materials or workmanship, as determined solely by our factory representative. Replacements will be shipped via freight collect. This warranty is void where evidence of misuse or abuse is present.